

ROBOTICS

# Product specification

## IRB 5710



Trace back information:  
Workspace 24A version a11  
Checked in 2024-03-05  
Skribenta version 5.5.019

## **Product specification**

**IRB 5710**

OmniCore

Document ID: 3HAC075188-001

Revision: F

The information in this manual is subject to change without notice and should not be construed as a commitment by ABB. ABB assumes no responsibility for any errors that may appear in this manual.

Except as may be expressly stated anywhere in this manual, nothing herein shall be construed as any kind of guarantee or warranty by ABB for losses, damage to persons or property, fitness for a specific purpose or the like.

In no event shall ABB be liable for incidental or consequential damages arising from use of this manual and products described herein.

This manual and parts thereof must not be reproduced or copied without ABB's written permission.

Keep for future reference.

Additional copies of this manual may be obtained from ABB.

Original instructions.

© Copyright 2022-2024 ABB. All rights reserved.  
Specifications subject to change without notice.

# Table of contents

Overview of this specification .....	7
<b>1 Description of IRB 5710</b> .....	<b>9</b>
1.1 About the IRB 5710 .....	9
1.2 About the IRB 5710 LeanID .....	12
1.3 Standards .....	15
1.3.1 Applicable standards .....	15
1.4 Maintenance and troubleshooting .....	16
<b>2 Technical data for IRB 5710</b> .....	<b>17</b>
2.1 Technical data .....	17
2.1.1 Technical data .....	17
2.1.2 Airborne noise level .....	21
2.1.3 Power consumption .....	22
2.1.4 Working range .....	23
2.1.5 Robot motion .....	30
2.2 Fitting equipment on the robot (robot dimensions) .....	31
2.3 Mechanical data for installation .....	42
2.4 Installing a base plate .....	44
2.5 Setting the system parameters for an inverted or a tilted robot .....	51
2.6 Working range alterations .....	53
2.6.1 Adjusting the working range .....	53
2.6.2 Installing movable mechanical stops on axis 1 (option 3323-1) .....	54
2.7 Calibration and references .....	56
2.7.1 Calibration methods .....	56
2.7.2 Synchronization marks and synchronization position for axes .....	58
2.7.3 Calibration movement directions for all axes .....	60
2.7.4 Fine calibration .....	61
2.7.5 Axis calibration on axis 6 .....	62
2.7.6 Calibration tools for Axis Calibration .....	64
2.7.7 Absolute Accuracy calibration .....	65
2.8 Load diagrams .....	67
2.8.1 Introduction .....	67
2.8.2 Diagrams .....	69
2.8.3 Maximum load and moment of inertia for full and limited axis 5 (center line down) movement .....	77
2.8.4 Wrist torque .....	79
2.8.5 Maximum TCP acceleration .....	80
2.9 Performance according to ISO 9283 .....	81
2.10 Velocity .....	82
2.11 Robot stopping distances and times .....	83
2.11.1 Robot stopping distances according to ISO 10218-1 .....	83
2.11.2 Measuring stopping distance and time .....	87
2.11.3 IRB 5710-110/2.3 .....	89
2.11.4 IRB 5710-110/2.3 Inv .....	97
2.11.5 IRB 5710-90/2.7 .....	105
2.11.6 IRB 5710-90/2.7 Inv .....	113
2.11.7 IRB 5710-90/2.3 LID .....	121
2.11.8 IRB 5710-90/2.3 LID Inv .....	129
2.11.9 IRB 5710-70/2.7 LID .....	137
2.11.10 IRB 5710-70/2.7 LID Inv .....	145
<b>3 Specification of variants and options</b> .....	<b>153</b>
3.1 Introduction to variants and options .....	153
3.2 Manipulator .....	154
3.3 Floor cables .....	161

## Table of contents

---

3.4	Application .....	162
3.4.1	Overview of DressPack options .....	162
3.4.2	DressPack for material handling .....	163
3.4.3	DressPack for spotwelding .....	168
3.4.4	Configuration result of DressPack options .....	172
3.4.5	Connector kits manipulator .....	175
	3.4.5.1 Base - Connector kits .....	176
	3.4.5.2 Axis 3 - Connector kits .....	178
	3.4.5.3 Axis 6 - Connector kits .....	181
3.4.6	Application floor cables .....	184
3.5	Warranty .....	185
<b>Index</b>		<b>187</b>

---

# Overview of this specification

## About this product specification

This product specification describes the performance of the manipulator or a complete family of manipulators in terms of:

- The structure and dimensional prints
- The fulfilment of standards, safety, and operating equipment
- The load diagrams, mounting or extra equipment, the motion, and the robot reach
- The specification of available variants and options

The specification covers the manipulator using the OmniCore controller.

## Usage

Product specifications are used to find data and performance about the product, for example to decide which product to buy. How to handle the product is described in the product manual.

The specification is intended for:

- Product managers and product personnel
- Sales and marketing personnel
- Order and customer service personnel

## Usage

Product specifications are used to find data and performance about the product, for example to decide which product to buy. How to handle the product is described in the product manual.

The specification is intended for:

- Product managers and product personnel
- Sales and marketing personnel
- Order and customer service personnel

## References

Documentation referred to in the product specification, is listed in the table below.

Document name	Document ID
<i>Product manual - IRB 5710</i>	<i>3HAC075184-001</i>
<i>Product manual - DressPack IRB 6740</i>	<i>3HAC088413-001</i>
<i>Circuit diagram - IRB 5710/IRB 5720</i>	<i>3HAC080367-001</i>
<i>Product manual - OmniCore V250XT Type B</i>	<i>3HAC087112-001</i>
<i>Product manual - OmniCore V400XT</i>	<i>3HAC081697-001</i>
<i>Technical reference manual - System parameters</i>	<i>3HAC065041-001</i>

*Continues on next page*



## Tip

All documents can be found via myABB Business Portal, [www.abb.com/myABB](http://www.abb.com/myABB).

## Revisions

Revision	Description
A	First edition.
B	Published in release 22D. The following updates are done in this revision: <ul style="list-style-type: none"><li>• Option 209-x Manipulator color RAL code added.</li><li>• Requirements for option 3316-1 <i>Upper arm cover</i> updated.</li></ul>
C	Published in release 23B. The following updates are done in this revision: <ul style="list-style-type: none"><li>• The updated robot stopping distances and times are moved to this document, and removed from the generic document, see <a href="#">Robot stopping distances and times on page 83</a>.</li><li>• Added DressPack options for spotwelding.</li><li>• Minor corrections.</li><li>• Text and image that presents the position for a nominal extra load on the upper arm is updated.</li></ul>
D	Published in release 23C. The following updates are done in this revision: <ul style="list-style-type: none"><li>• Corrected information about available options for DressPack.</li></ul>
E	Published in release 23D. The following updates are made in this revision: <ul style="list-style-type: none"><li>• Added attachment holes for equipment on lower arm dimension drawing.</li><li>• Added support for OmniCore V400XT.</li><li>• Corrected the content of the connector kit, <a href="#">Option 3331-1, Weld Proc 2-4 base on page 177</a>.</li></ul>
F	Published in release 24A. The following updates are made in this revision: <ul style="list-style-type: none"><li>• Corrected position descriptions for illustrations of DressPack connection plates at axis 3 interface and at the base.</li><li>• Added DressPack options for CC-Link.</li></ul>



# 1 Description of IRB 5710

## 1.1 About the IRB 5710

---

### General introduction

ABB is expanding its large size robot portfolio with IRB 5710, offering faster performance, more accurate, expanded mounting options, and advanced foundry protection than other competing robots in its class.

The IRB 5710 is available in four variants spanning various options for payload from 70 kg to 110 kg, reach from 2.3 m to 2.7 m.

---

### Intended use

IRB 5710 is ideal for use in material handling, machine tending, and high precision assembly applications in the Electric Vehicle (EV), automotive, and the general industries. For Electric Vehicles, robots can handle an array of tasks, including EV battery module picking and placing, high precision assembly and parts handling. For general industries, the robots can be used for a wide range of tasks in die casting, material removal, cleaning, spraying and general high precision applications.

ABB robots are capable of high accelerations and speeds. It is generally recommended to use Robot Studio to find out if a robot model is suitable for a specific application and duty factor. In the case of intense use of robots, optional cooling fans may be required, and the expected component life of gearboxes and motors may be affected. Robot Studio is an excellent tool to help with the assessment of the duty factor and the selection of the most suitable robot variant.

*Continues on next page*

# 1 Description of IRB 5710

## 1.1 About the IRB 5710

*Continued*

### Available variants

The IRB 5710 is available in the following variants.

#### Variants with standard wrist

Robot variant	IRB 5710-110/2.3	IRB 5710-90/2.7
Handling capacity	110 kg	90 kg
Reach	2.30 m	2.70 m

#### Variants with LeanID

Robot variant	IRB 5710-90/2.3 LID	IRB 5710-70/2.7 LID
Handling capacity	90 kg	70 kg
Reach	2.30 m	2.70 m

### Robot axes

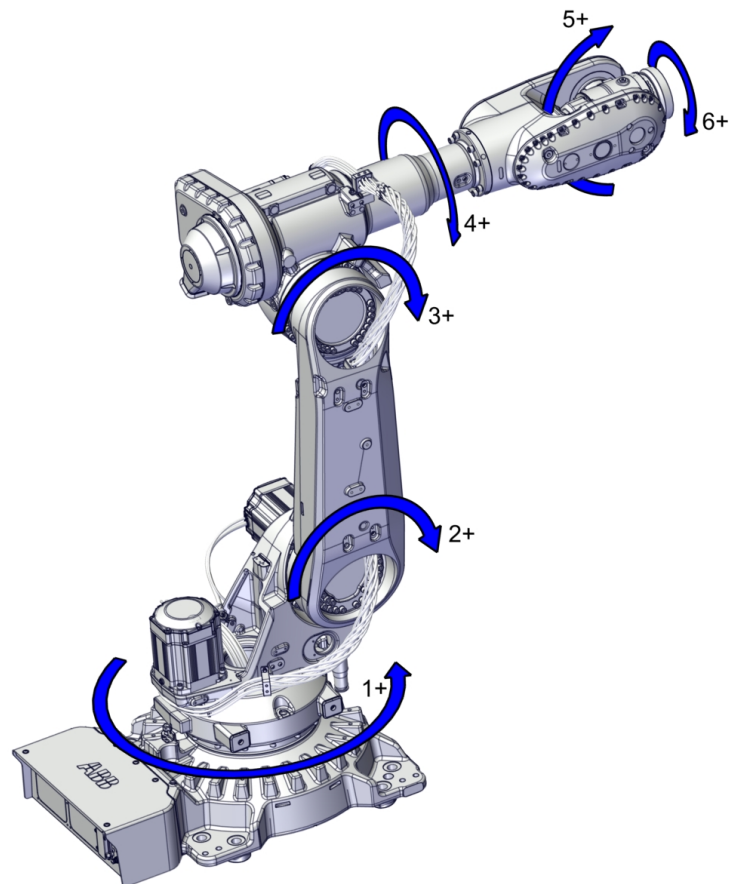

xx2100002527

*Continues on next page*

### Control system

The robot is equipped with the OmniCore controller and robot control software, RobotWare. RobotWare supports every aspect of the robot system, such as motion control, development and execution of application programs, communication etc. See *Operating manual - OmniCore*.

We have added a range of software products - all falling under the umbrella designation of Active Safety - to protect not only personnel in the unlikely event of an accident, but also robot tools, peripheral equipment and the robot itself.

The IRB 5710 manipulator can be connected to the following robot controllers:

- OmniCore V250XT Type B
- OmniCore V400XT

---

### Safety

Safety standards valid for complete robot, manipulator and controller.

---

### Additional functionality

For additional functionality, the robot can be equipped with optional software for application support - for example communication features - network communication - and advanced functions such as multitasking, sensor control etc. For a complete description on optional software, see the product specification for the robot controller, listed in [References on page 7](#).

# 1 Description of IRB 5710

## 1.2 About the IRB 5710 LeanID

### 1.2 About the IRB 5710 LeanID

#### About the DressPack

The IRB 5710 can be equipped with the well-integrated cable and hose packages in the DressPack options. The DressPack is designed together with the manipulator to offer a complete solution. The DressPack is designed to fit a wide variety of applications, like machine tending, material handling and spot welding and are well integrated into the robot system to ensure long life and large working range.

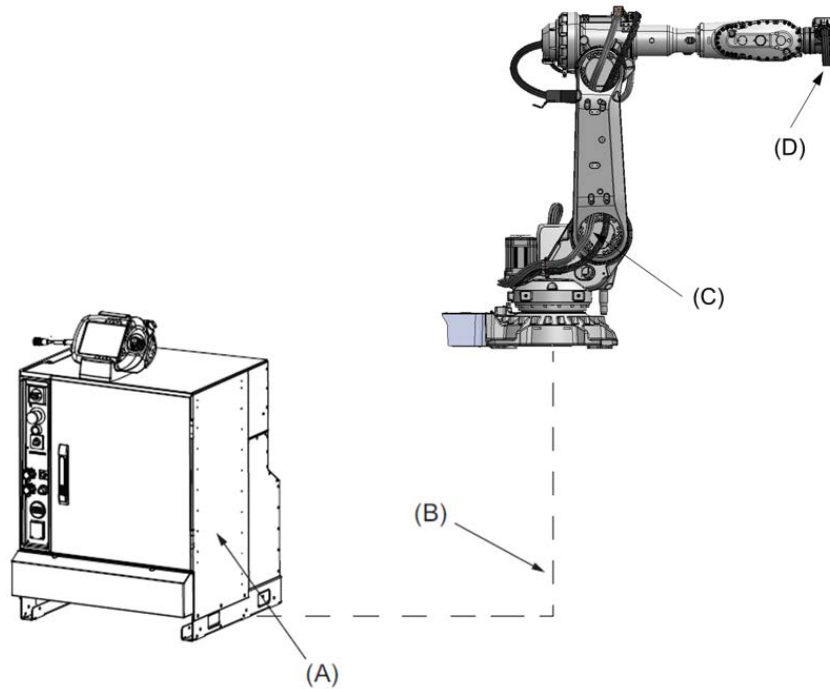

xx2100002465

Pos	Description
A	Robot controller
B	DressPack, floor
C	DressPack, lower arm
D	DressPack, upper arm

*Continues on next page*

### Available DressPack for IRB 5710

To support the variety of complexity in the operation/wrist movements, there are different solutions available.

The lower arm DressPack (base - axis 3) has the same routing and design for all manipulator variants, but differs for material handling and spot welding. The DressPack for material handling (MH) is routed inside the manipulator lower arm while the DressPack for spot welding (SW) runs outside of the lower arm.

The upper arm DressPack options (axis 3 - 6) are available in different design solutions, *LeanID - MH*, *LeanID - SW* and *MH3*. The main difference between LeanID and MH3 is that LeanID is guided across the axis 6 center of rotation by utilizing a process turning disc instead of the standard turning disc. This allows for a controlled and predictable motion pattern of the DressPack. The MH3 DressPack is designed for less complex wrist movements and requires the integrator to manage the DressPack routing at axis 6.

The LeanID Empty Conduit is an empty casing without cabling.

Robot variant	DressPack variants	
	Base - axis 3	axis 3 - 6
IRB 5710-110/2.3	MH, SW	MH3
IRB 5710-90/2.7	MH, SW	MH3
IRB 5710-90/2.3 LID	MH, SW	LeanID - MH, LeanID - SW
IRB 5710-70/2.7 LID	MH, SW	LeanID - MH, LeanID - SW

*Continues on next page*

# 1 Description of IRB 5710

## 1.2 About the IRB 5710 LeanID

Continued

Illustration of DressPack designs

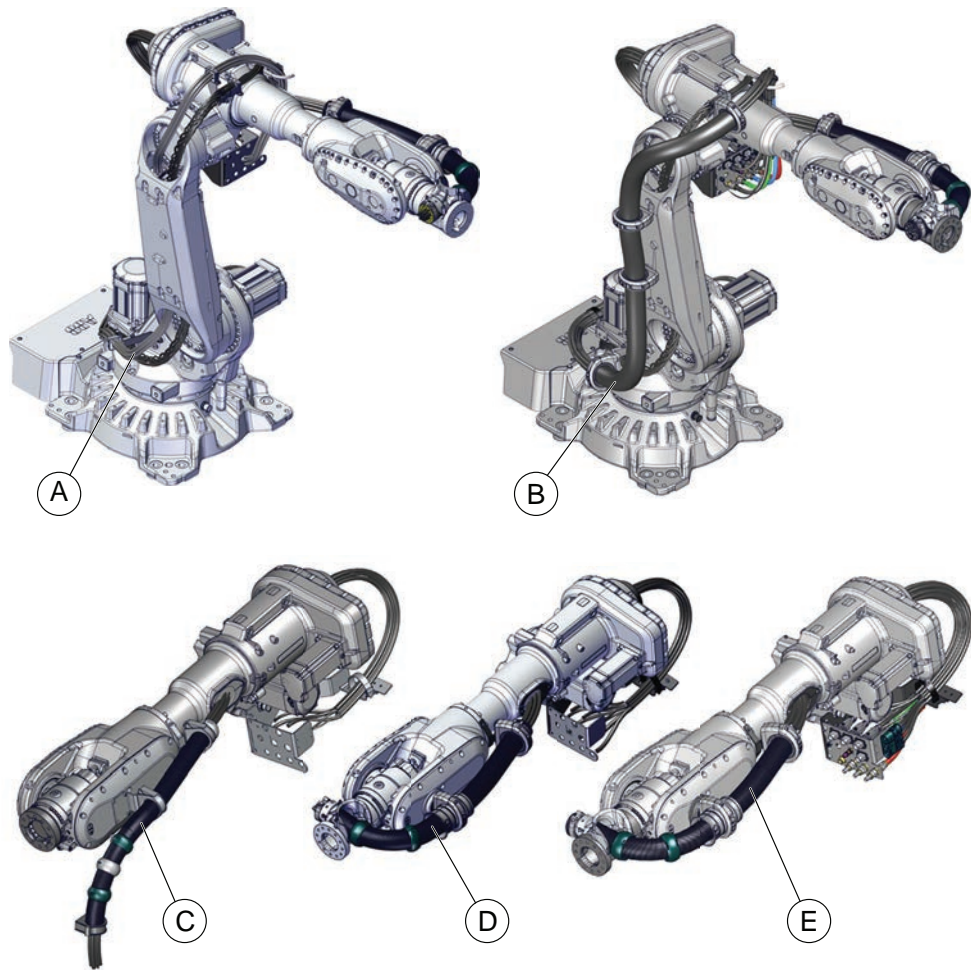

xx2100002588

	Description	DressPack variant	Robot variant
A	DressPack base - axis 3	MH	IRB 5710-110/2.3 IRB 5710-90/2.7 IRB 5710-90/2.3 LID IRB 5710-70/2.7 LID
B	DressPack base - axis 3	SW	IRB 5710-110/2.3 IRB 5710-90/2.7 IRB 5710-90/2.3 LID IRB 5710-70/2.7 LID
C	DressPack axis 3 - 6	MH3	IRB 5710-110/2.3 IRB 5710-90/2.7
D	DressPack axis 3 - 6	LeanID - MH	IRB 5710-90/2.3 LID IRB 5710-70/2.7 LID
E	DressPack axis 3 - 6	LeanID - SW	IRB 5710-90/2.3 LID IRB 5710-70/2.7 LID
-	DressPack axis 3 - 6	LeanID Empty Conduit	IRB 5710-90/2.3 LID IRB 5710-70/2.7 LID

### 1.3 Standards

#### 1.3.1 Applicable standards

##### General

The product is compliant with ISO 10218-1:2011, *Robots for industrial environments - Safety requirements - Part 1 Robots*, and applicable parts in the normative references, as referred to from ISO 10218-1:2011. In case of deviation from ISO 10218-1:2011, these are listed in the declaration of incorporation. The declaration of incorporation is part of the delivery.

##### Robot standards

Standard	Description
ISO 9283	Manipulating industrial robots – Performance criteria and related test methods
ISO 9787	Robots and robotic devices – Coordinate systems and motion nomenclatures
ISO 9946	Manipulating industrial robots – Presentation of characteristics

##### Other standards used in design

Standard	Description
IEC 60204-1	Safety of machinery - Electrical equipment of machines - Part 1: General requirements, normative reference from ISO 10218-1
IEC 61000-6-2	Electromagnetic compatibility (EMC) – Part 6-2: Generic standards – Immunity standard for industrial environments
IEC 61000-6-4	Electromagnetic compatibility (EMC) – Part 6-4: Generic standards – Emission standard for industrial environments
ISO 13849-1:2006	Safety of machinery - Safety related parts of control systems - Part 1: General principles for design, normative reference from ISO 10218-1

##### Region specific standards and regulations

Standard	Description
ANSI/RIA R15.06	Safety requirements for industrial robots and robot systems
CAN/CSA Z 434-03 CAN/CSA Z 434-14	Industrial robots and robot Systems - General safety requirements
EN ISO 10218-1	Robots and robotic devices — Safety requirements for industrial robots — Part 1: Robots

# 1 Description of IRB 5710

---

## 1.4 Maintenance and troubleshooting

### 1.4 Maintenance and troubleshooting

---

#### General

The robot requires only minimum maintenance during operation. It has been designed to make it as easy to service as possible:

- Maintenance-free AC motors are used.
- Oil is used for the gearboxes.
- The cabling is routed for longevity, and in the unlikely event of a failure, its modular design makes it easy to change.

---

#### Maintenance

The maintenance intervals depend on the use of the robot. The required maintenance activities also depend on the selected options. For detailed information on maintenance procedures, see the maintenance section in *Product manual - IRB 5710*.

---

#### Troubleshooting

The robot has built-in communication that shows information on the FlexPendant. These messages facilitates troubleshooting and are an integral part of the control system. Troubleshooting procedures are describes in the product manual for the manipulator and the controller respectively.



## 2 Technical data for IRB 5710

### 2.1 Technical data

#### 2.1.1 Technical data

##### Weight, robot

The table shows the weight of the robot.

Robot model	Nominal weight <sup>i</sup>
IRB 5710-110/2.3	830 kg
IRB 5710-90/2.7	830 kg
IRB 5710-90/2.3 LID	890 kg
IRB 5710-70/2.7 LID	885 kg

<sup>i</sup> Option Inverted (3317-1) adds approximately 15 kg to the nominal weight.



##### Note

The weight does not include additional options, tools and other equipment fitted on the robot.

The weight does not include the weight of the DressPack.

##### Mounting positions

The table shows valid mounting positions and the installation (mounting) angle for the manipulator.

Mounting position	Installation angle
Floor mounted	0°
Inverted	180°
Tilted	0-20°



##### Note

The actual mounting angle must always be configured in the system parameters, otherwise the performance and lifetime is affected. See the product manual for details.

*Continues on next page*

## 2 Technical data for IRB 5710

### 2.1.1 Technical data

Continued

#### Loads on foundation, robot

The illustration shows the directions of the robots stress forces. The directions are valid for all floor mounted, tilted mounted and inverted robots.

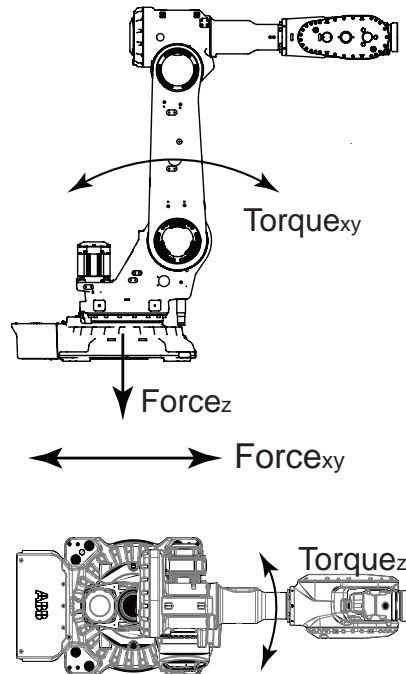

xx2100002622

The table shows the various forces and torques working on the robot during different kinds of operation.



#### Note

These forces and torques are extreme values that are rarely encountered during operation. The values also never reach their maximum at the same time!



#### WARNING

The robot installation is restricted to the mounting options given in following load table(s).

#### Floor mounted

Force	Endurance load (in operation)	Maximum load (emergency stop)
Force xy	±6.7 kN	±14.1 kN
Force z	9.6 ±4.4 kN	9.6 ±10.7 kN
Torque xy	±13.9 kNm	±23.7 kNm
Torque z	±4.2 kNm	±10.2 kNm

#### Inverted

Force	Endurance load (in operation)	Max. load (emergency stop)
Force xy	±6.1 kN	±14.4 kN

Continues on next page

Force	Endurance load (in operation)	Max. load (emergency stop)
Force z	-9.6 ±4.3 kN	-9.6 ±10.2 kN
Torque xy	±13 kNm	±23 kNm
Torque z	±4.2 kNm	±10.2 kNm

Tilted

Force	Endurance load (in operation)	Max. load (emergency stop)
Force xy	±9.4 kN	±16.5 kN
Force z	8.9 ±4.5 kN	8.9 ±11.1 kN
Torque xy	±14.7 kNm	±24.6 kNm
Torque z	±4.2 kNm	±10.4 kNm



**Note**

Values valid for maximum tilted robot.

**Requirements, foundation**

The table shows the requirements for the foundation where the weight of the installed robot is included:

Requirement	Value	Note
Flatness of foundation surface	0.3 mm	Flat foundations give better repeatability of the resolver calibration compared to original settings on delivery from ABB. The value for levelness aims at the circumstance of the anchoring points in the robot base. In order to compensate for an uneven surface, the robot can be recalibrated during installation. If resolver/encoder calibration is changed this will influence the absolute accuracy.
Minimum resonance frequency	22 Hz <b>Note</b> It may affect the manipulator lifetime to have a lower resonance frequency than recommended.	The value is recommended for optimal performance. Due to foundation stiffness, consider robot mass including equipment. <sup>i</sup> For information about compensating for foundation flexibility, see the description of <i>Motion Process Mode</i> in the manual that describes the controller software option, see <a href="#">References on page 7</a> .

<sup>i</sup> The minimum resonance frequency given should be interpreted as the frequency of the robot mass/inertia, robot assumed stiff, when a foundation translational/torsional elasticity is added, i.e., the stiffness of the pedestal where the robot is mounted. The minimum resonance frequency should not be interpreted as the resonance frequency of the building, floor etc. For example, if the equivalent mass of the floor is very high, it will not affect robot movement, even if the frequency is well below the stated frequency. The robot should be mounted as rigid as possible to the floor.  
Disturbances from other machinery will affect the robot and the tool accuracy. The robot has resonance frequencies in the region 10 – 20 Hz and disturbances in this region will be amplified, although somewhat damped by the servo control. This might be a problem, depending on the requirements from the applications. If this is a problem, the robot needs to be isolated from the environment.

Continues on next page

## 2 Technical data for IRB 5710

---

### 2.1.1 Technical data

*Continued*

---

#### Storage conditions, robot

The table shows the allowed storage conditions for the robot:

Parameter	Value
Minimum ambient temperature	-25 °C
Maximum ambient temperature	55 °C
Maximum ambient temperature (less than 24 hrs)	70 °C
Maximum ambient humidity	95%

---

#### Operating conditions, robot

The table shows the allowed operating conditions for the robot:

Parameter	Value
Minimum ambient temperature	5 °C <sup>i</sup>
Maximum ambient temperature	50 °C
Maximum ambient humidity	95% at constant temperature

<sup>i</sup> At low environmental temperature < 10°C is, as with any other machine, a warm-up phase recommended to be run with the robot. Otherwise there is a risk that the robot stops or run with lower performance due to temperature dependent oil and grease viscosity.

---

#### Protection classes, robot

The table shows the available protection types of the robot, with the corresponding protection class.

Protection type	Protection class <sup>i</sup>
Manipulator, protection type Standard	IP67
Manipulator, protection type Foundry Plus 2	IP67

<sup>i</sup> According to IEC 60529.

---

#### Environmental information

The product complies with IEC 63000. *Technical documentation for the assessment of electrical and electronic products with respect to the restriction of hazardous substances.*

2.1.2 Airborne noise level

Airborne noise level

Description	Note	Value
Airborne noise level	The sound pressure level outside the working space.	70 dB (A) Leq

The noise emission is measured at four points on a radius 1 m outside the robots maximum working range and at 1.5 m above the robot base level, while the manipulator follows a defined cycle according to VDMA 24608, at max performance and payload.

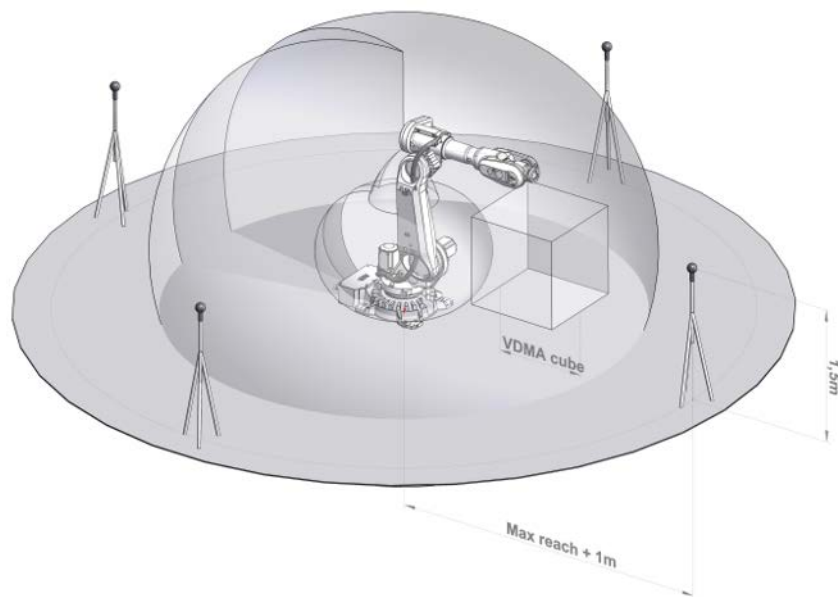

xx2100002505



**Note**

The noise emission from a robot, in an actual application, depends on the programmed path, payload, cycle time, mounting position, environment, etc.

## 2 Technical data for IRB 5710

### 2.1.3 Power consumption

### 2.1.3 Power consumption

#### Power consumption at max load

Variant <sup>i</sup>	ISO cube	Robot in calibration position	
	Power consumption at maximum velocity (kW)	Power consumption at brakes engaged (kW)	Power consumption at brakes disengaged (kW)
IRB 5710-110/2.3	2.9	0.25	0.66
IRB 5710-90/2.7	2.3	0.23	0.68

<sup>i</sup> LID manipulator variants are considered to have the same data as specified variants with the same reach.

#### ISO cube

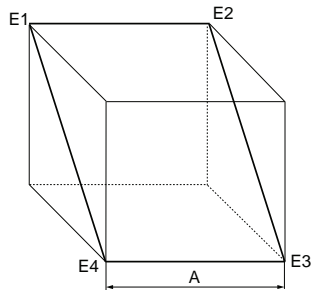

xx1000000101

Pos	Description
A	1,000 mm



#### Note

If measuring the power consumption at the installation site, the returned power to the grid needs to be taken in to account.

2.1.4 Working range

Illustration, working range IRB 5710-110/2.3

This illustration shows the unrestricted working range of the robot.

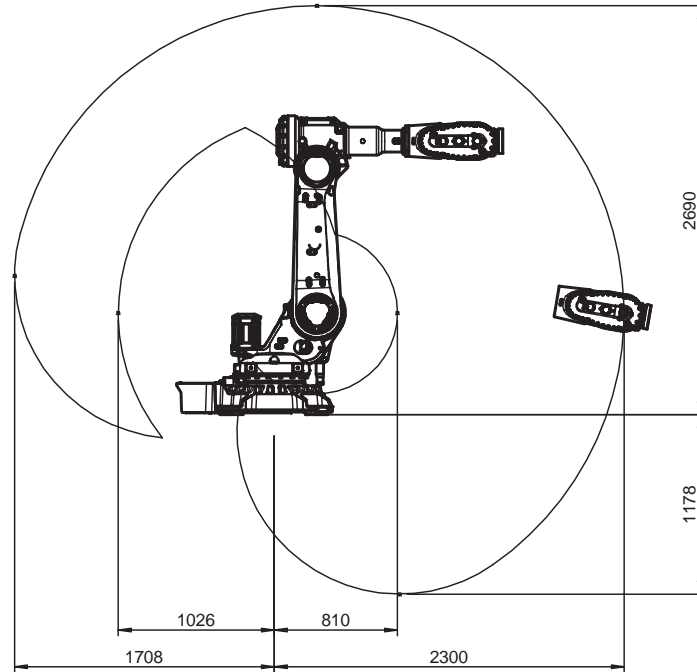

xx2100000387

IRB 5710-110/2.3 inverted (with option 3317-1)

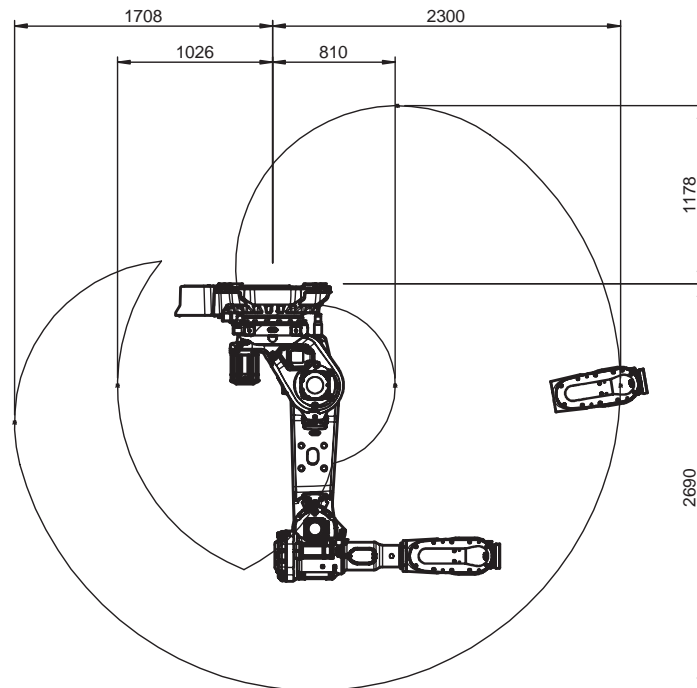

xx2100002542

Continues on next page

## 2 Technical data for IRB 5710

### 2.1.4 Working range

Continued

#### Illustration, working range IRB 5710-90/2.7

This illustration shows the unrestricted working range of the robot.

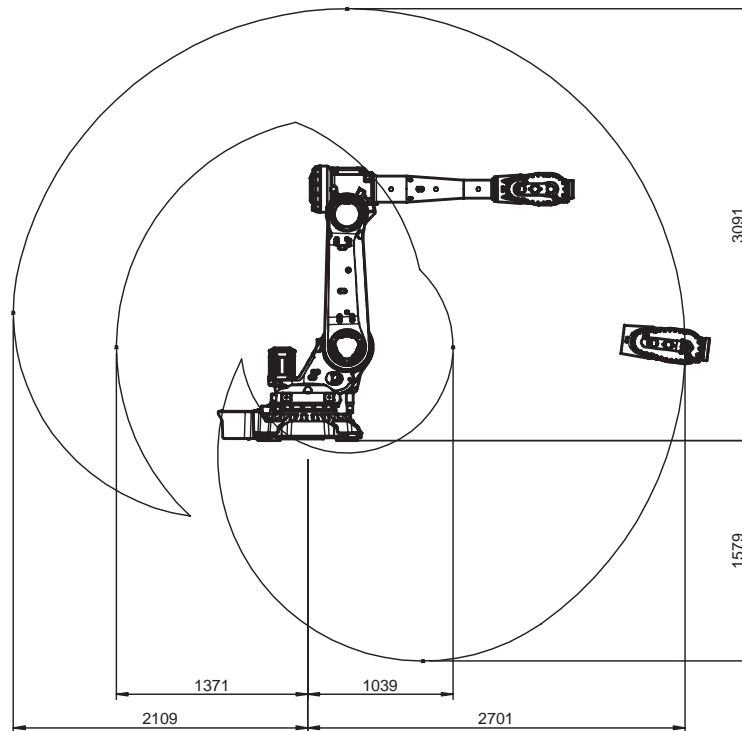

xx210000388

#### IRB 5710-90/2.7 inverted (with option 3317-1)

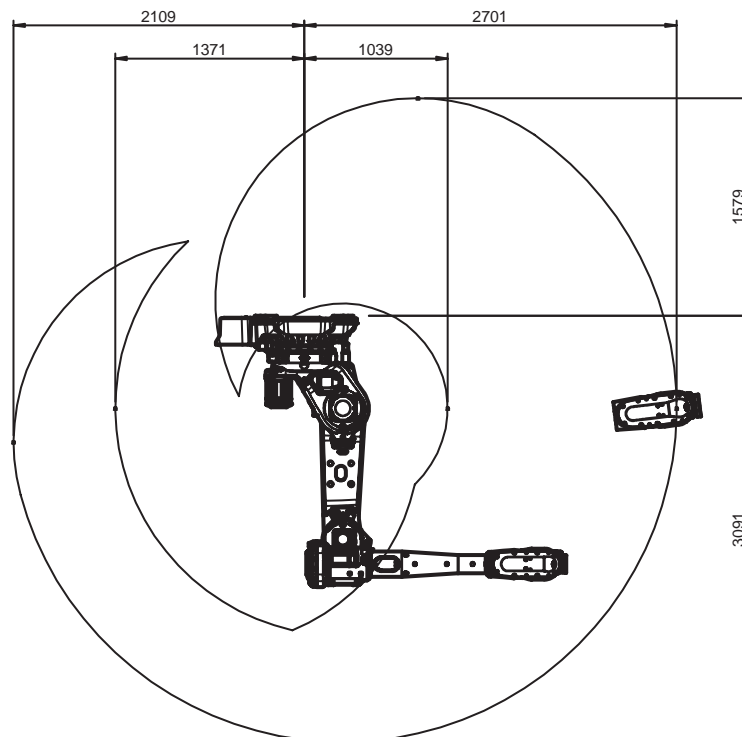

xx2100002543

Continues on next page



Illustration, working range IRB 5710-90/2.3 LID

This illustration shows the unrestricted working range of the robot.

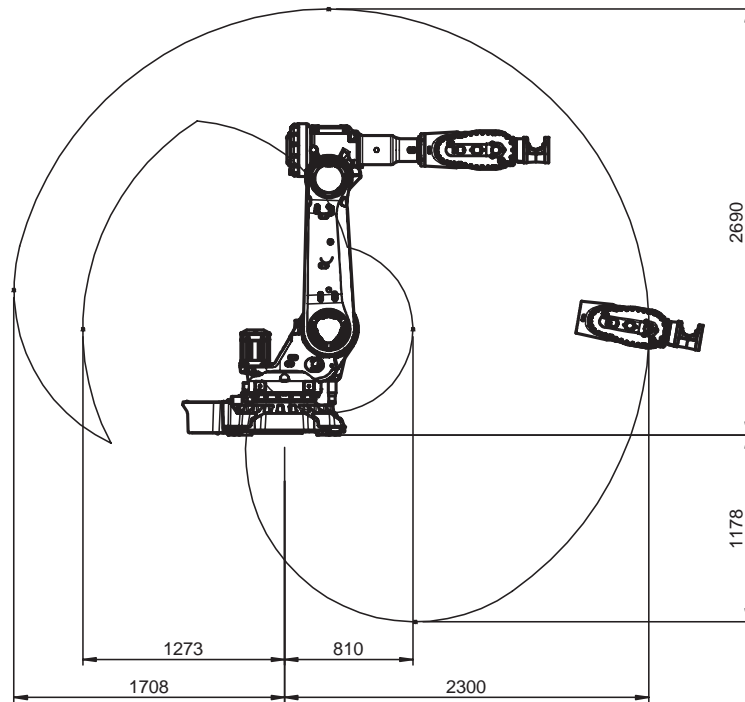

xx210000389

IRB 5710-90/2.3 LID inverted (with option 3317-1)

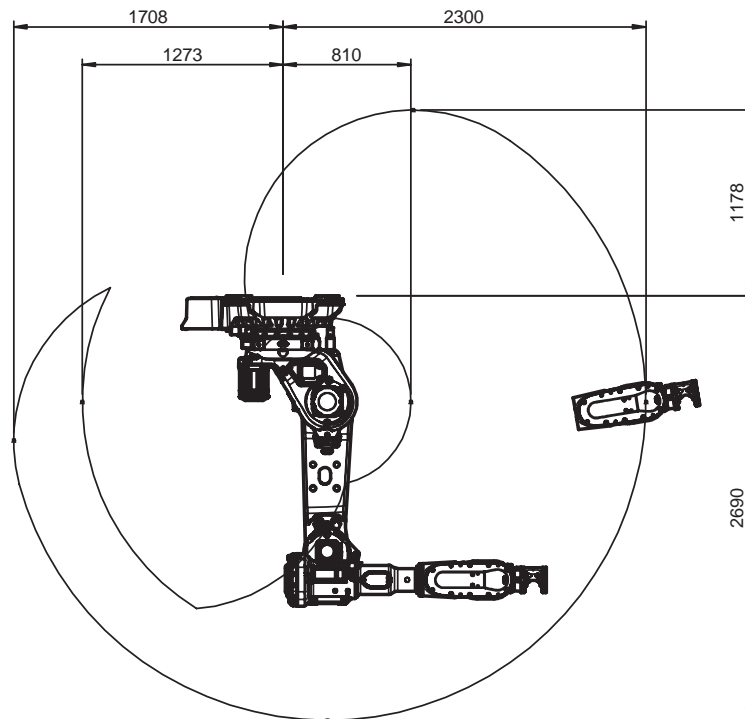

xx2100002544

Continues on next page

## 2 Technical data for IRB 5710

### 2.1.4 Working range

Continued

#### Illustration, working range IRB 5710-70/2.7 LID

This illustration shows the unrestricted working range of the robot.

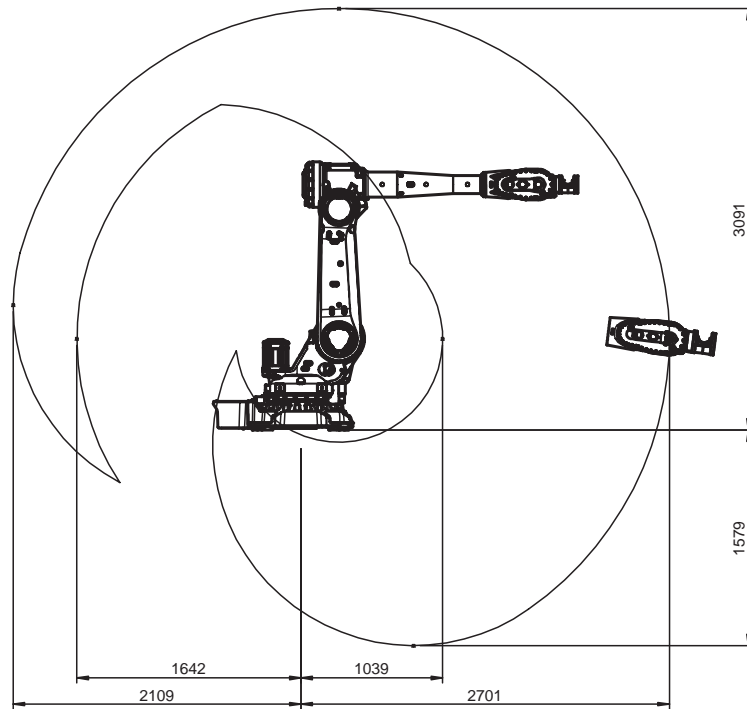

xx2100000390

#### IRB 5710-70/2.7 LID inverted (with option 3317-1)

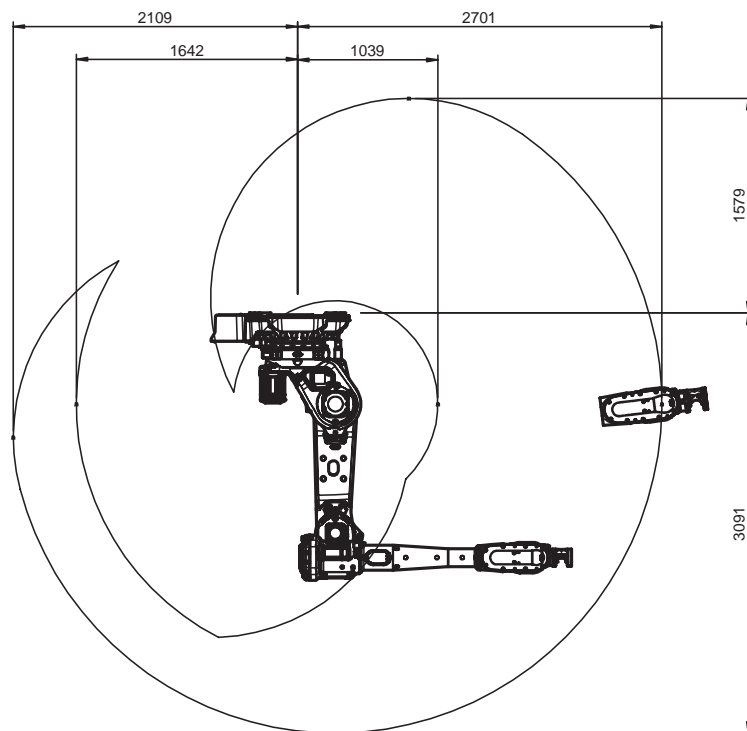

xx2100002545

Continues on next page

Top view of working range

IRB 5710-110/2.3, IRB 5710-90/2.3 LID

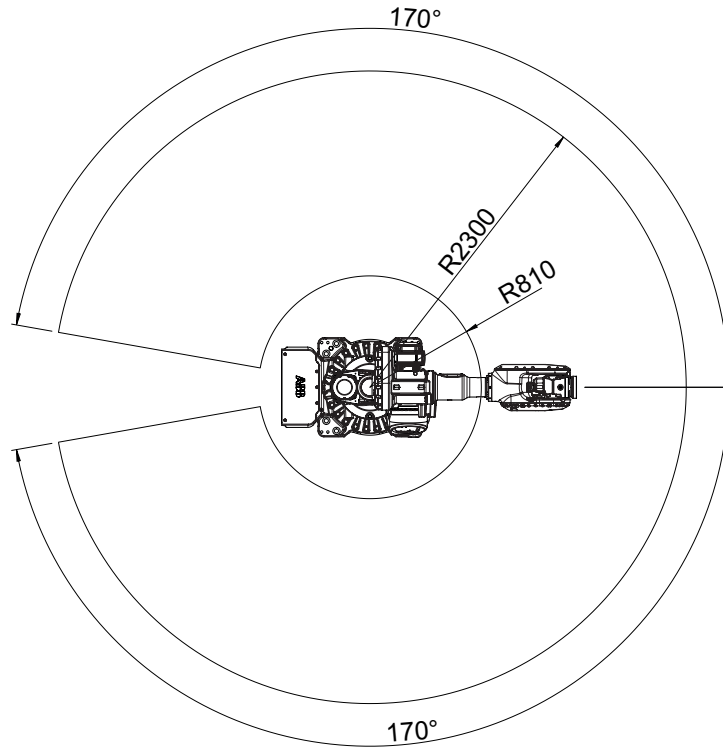

xx210000401

Continues on next page

## 2 Technical data for IRB 5710

### 2.1.4 Working range

Continued

IRB 5710-90/2.7, IRB 5710-70/2.7 LID

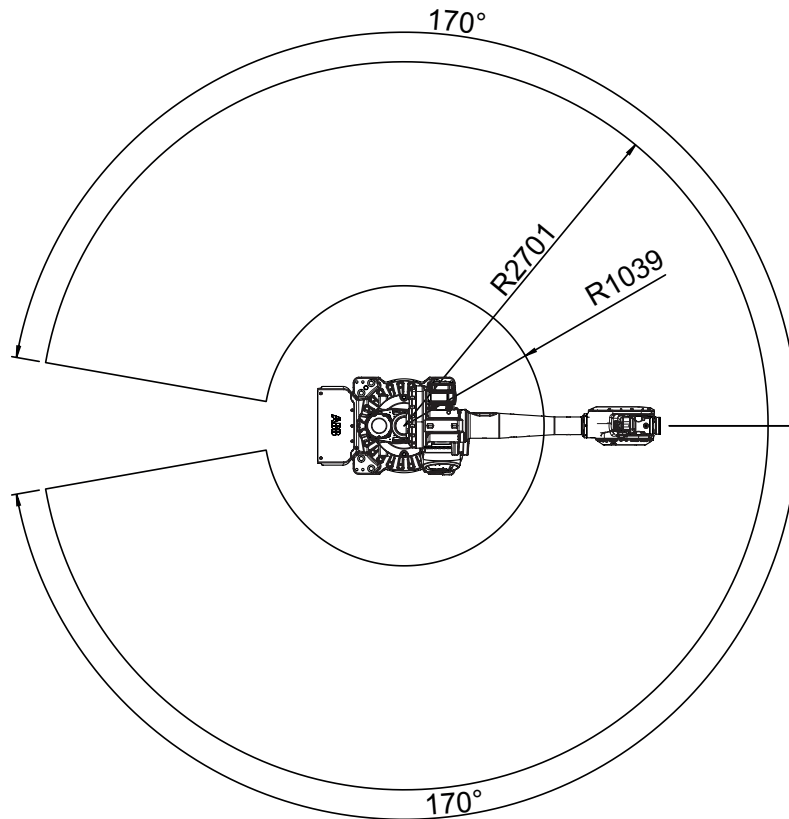

xx210000402

### Working range

Axis	Working range	Note
Axis 1	$\pm 170^\circ$	The default working range for axis 1 can be extended as an option.
	$\pm 220^\circ$ <sup>i</sup>	
Axis 2	$-75^\circ / +145^\circ$	
Axis 3	$-180^\circ / +70^\circ$ (IRB 5710-110/2.3, IRB 5710-90/2.7)	
	$-160^\circ / +70^\circ$ (IRB 5710-90/2.3 LID, IRB 5710-70/2.7 LID)	
Axis 4	$\pm 300^\circ$	
Axis 5	$\pm 130^\circ$ (IRB 5710-110/2.3, IRB 5710-90/2.7)	
	$\pm 120^\circ$ <sup>ii</sup> (IRB 5710-90/2.3 LID, IRB 5710-70/2.7 LID)	

Continues on next page

Axis	Working range	Note
Axis 6	$\pm 360^\circ$ (IRB 5710-110/2.3, IRB 5710-90/2.7) $\pm 200^\circ$ <sup>ii</sup> (IRB 5710-90/2.3 LID, IRB 5710-70/2.7 LID)	

- i Option *Extended Working Range Axis 1* (3324-1)  
Not valid for option *Inverted* (3317-1)  
Not valid with DressPack options for spot welding.
- ii Maximum combined movements reduced.  
See [Working range axis 5 and axis 6 for IRB 5710-90/2.3 LID, IRB 5710-70/2.7 LID \(option axis 3-6 \[3326-x\]\) on page 30.](#)

### Working range limitation

The working range of axis 1 can be reduced by altering the parameter values. Installation of additional mechanical stops is recommended. See [Working range alterations on page 53.](#)

## 2 Technical data for IRB 5710

### 2.1.5 Robot motion

### 2.1.5 Robot motion

#### Limitations of robot movements for LeanID

Robot variants with LeanID have restricted working range implemented in RobotWare. See [Working range on page 28](#).

#### Working range axis 5 and axis 6 for IRB 5710-90/2.3 LID, IRB 5710-70/2.7 LID (option axis 3-6 [3326-x])

The allowed working area for axis 6 related to axis 5 position is shown in the figure below.

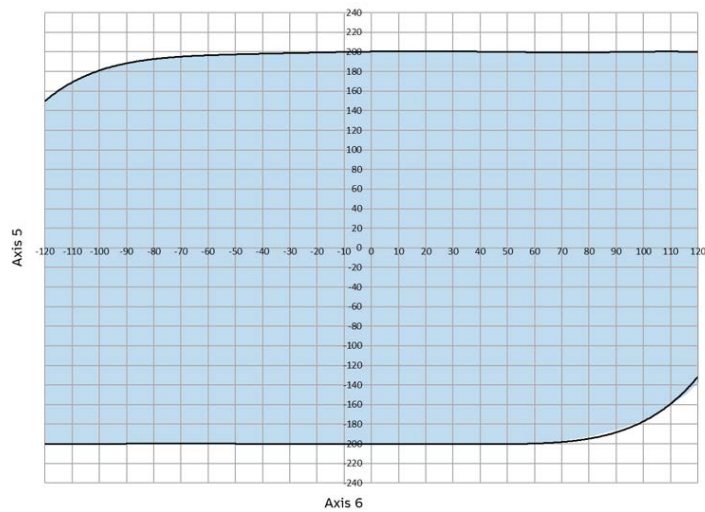

xx2100002452



#### Note

The working range for LeanID variants is controlled and protected by software.

2.2 Fitting equipment on the robot (robot dimensions)

Robot dimensions

The figure shows the dimension of the robot. For more information regarding geometry, see CAD models online.

IRB 5710-110/2.3

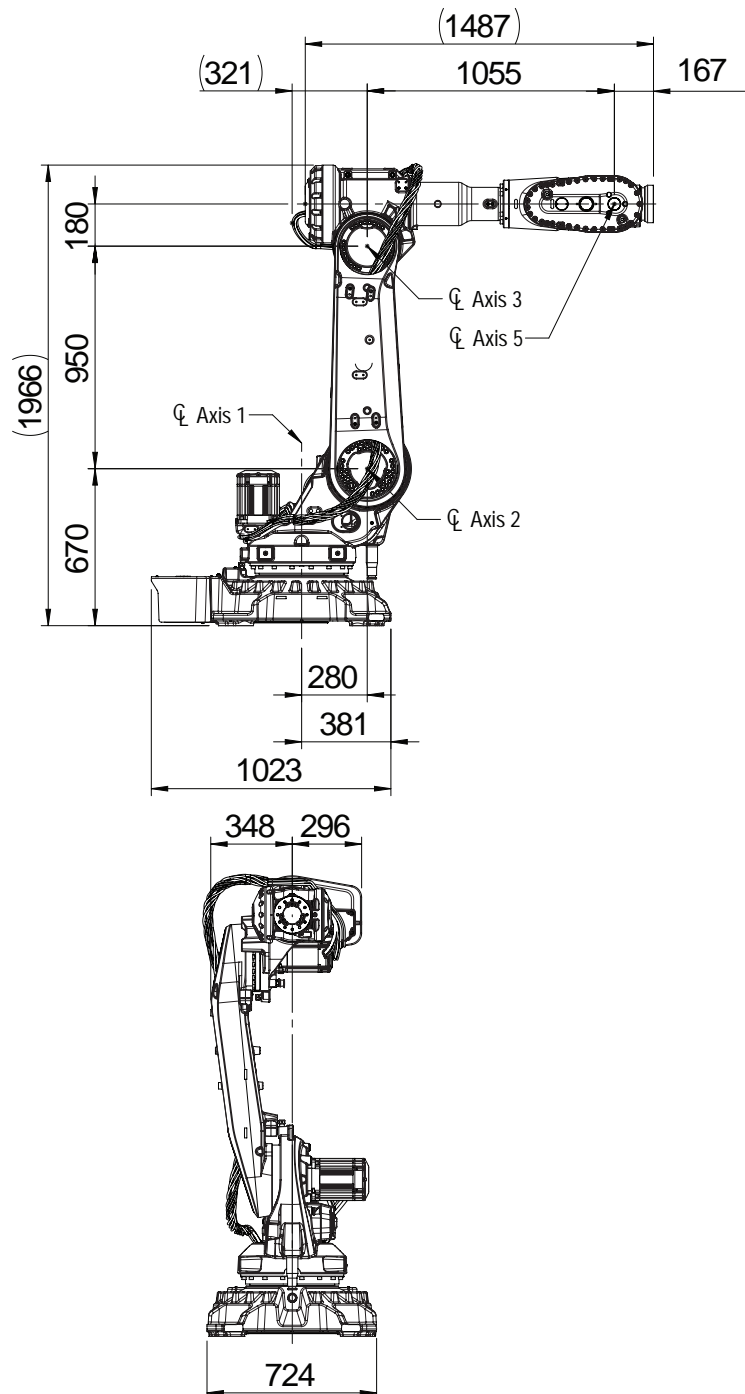

xx210000792

Continues on next page

## 2 Technical data for IRB 5710

### 2.2 Fitting equipment on the robot (robot dimensions)

Continued

IRB 5710-90/2.7

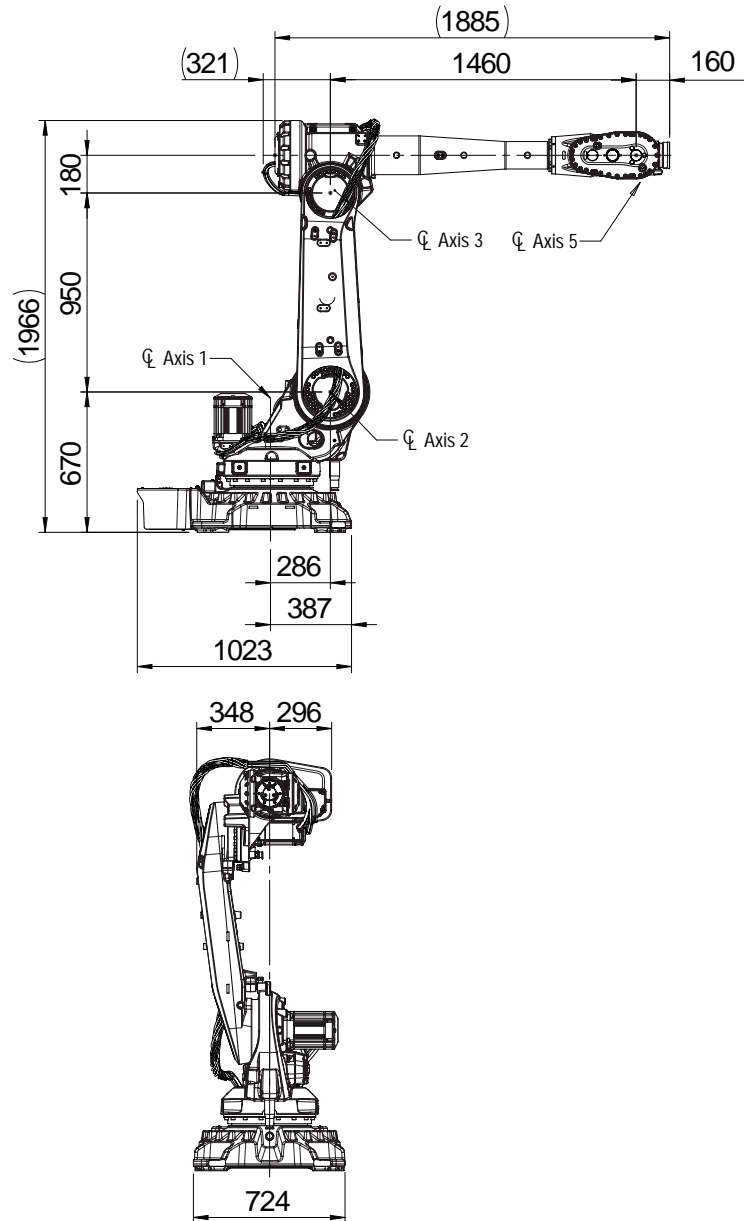

xx210000794

Continues on next page



## 2 Technical data for IRB 5710

### 2.2 Fitting equipment on the robot (robot dimensions)

*Continued*

IRB 5710-90/2.3 LID

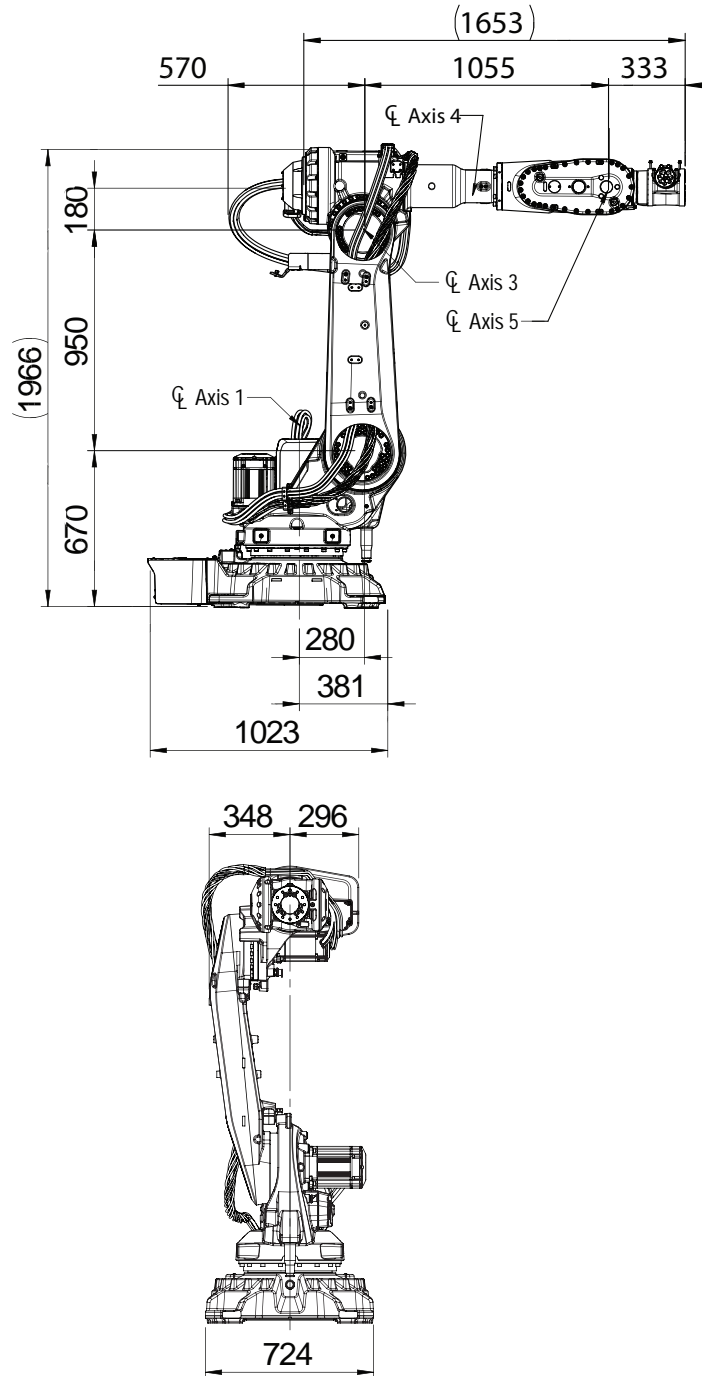

xx210000793

*Continues on next page*

## 2 Technical data for IRB 5710

### 2.2 Fitting equipment on the robot (robot dimensions)

Continued

IRB 5710-70/2.7 LID

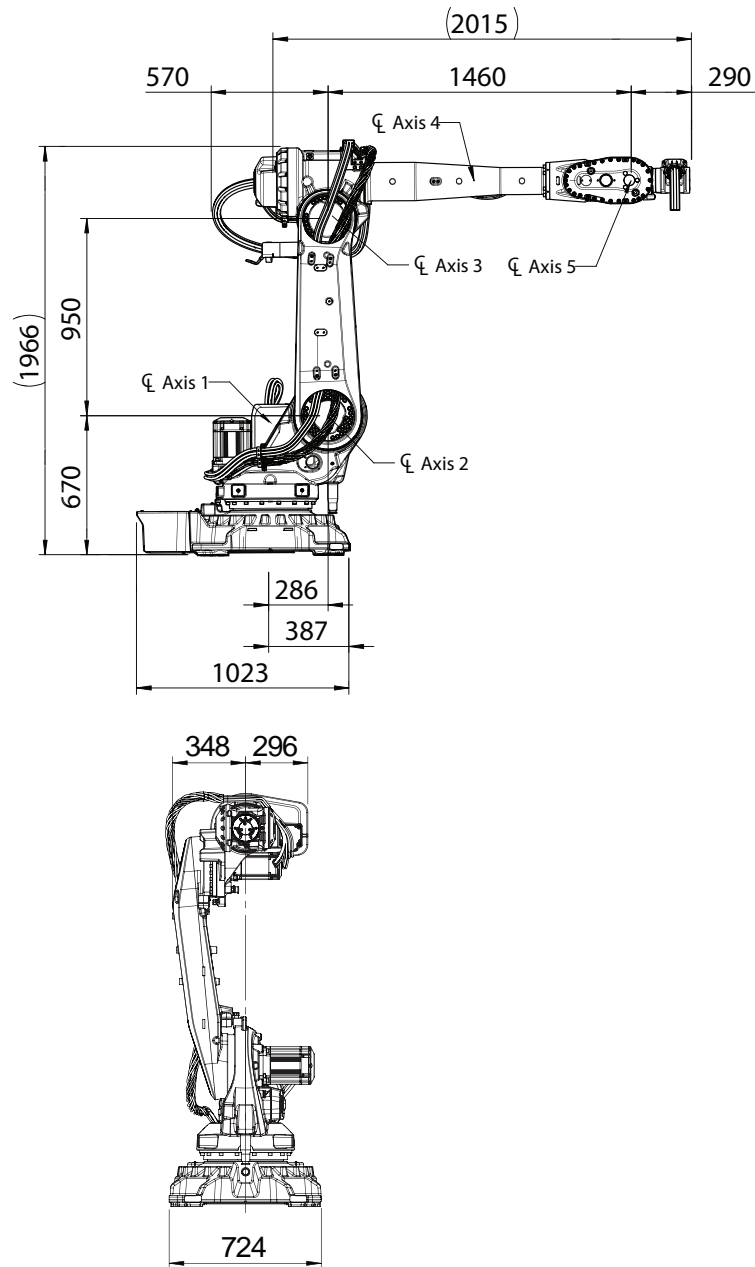

xx2100000795

#### Extra load on the robot

Extra loads can be mounted on robot. Definitions of dimensions and masses are shown in the following figures. The robot is supplied with holes for fitting extra equipment.

Continues on next page

Maximum allowed arm load depends on center of gravity of arm load and robot payload.

Frame

The table and figure shows allowed extra load on the frame.

	Description
Permitted extra load on frame	$J_H = 100 \text{ kgm}^2$
Recommended position (see the following figure)	$J_H = J_{H0} + M4 \times R^2$ where: <ul style="list-style-type: none"> <li>• <math>J_{H0}</math> is the moment of inertia of the equipment</li> <li>• <math>R</math> is the radius (m) from the center of axis 1</li> <li>• <math>M4</math> is the total mass (kg) of the equipment including bracket and harness (<math>\leq 250 \text{ kg}</math>)</li> </ul>

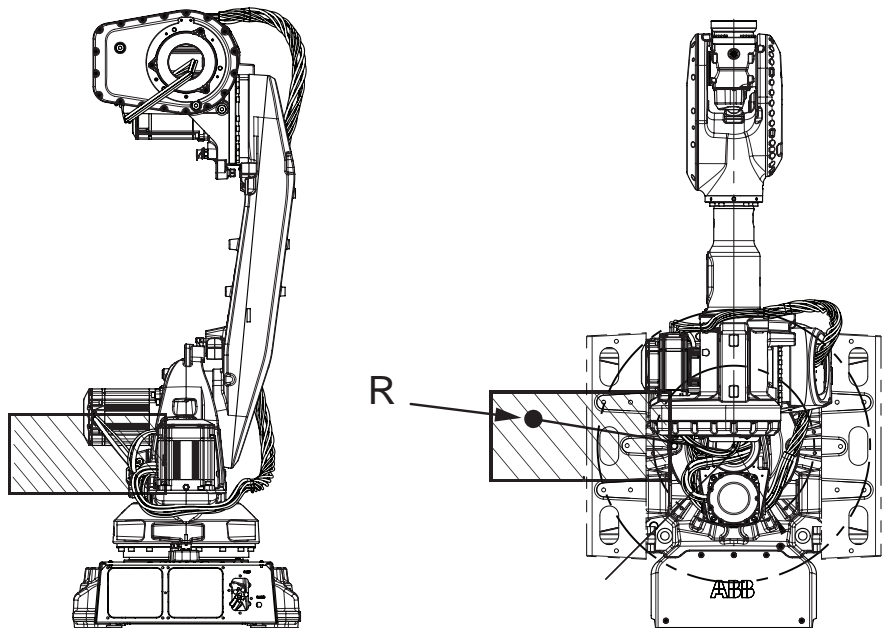

xx210000824

Continues on next page

## 2 Technical data for IRB 5710

### 2.2 Fitting equipment on the robot (robot dimensions)

*Continued*

#### Upper arm

The figure shows the position for a nominal extra load of 20 kg on the upper arm housing on a standard robot. For more precise calculations of allowed extra load up to maximum 200 kg in combination with the reduced payload, use RobotStudio add-in RobotLoad or contact ABB.

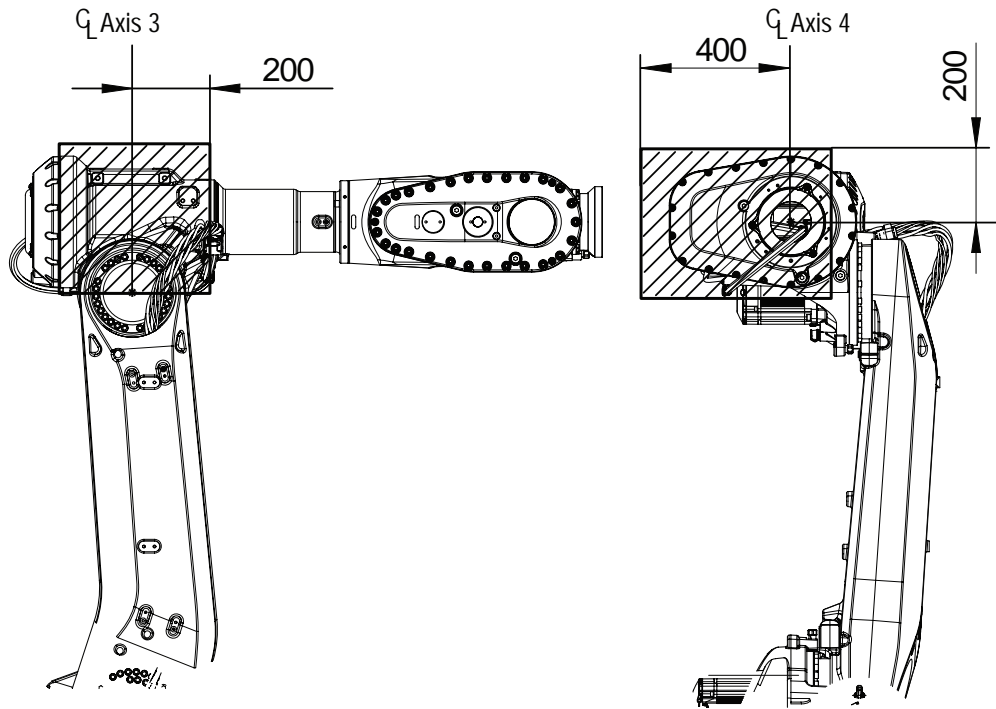

xx2200002036

*Continues on next page*

Attachment holes for fitting extra equipment

The robot is supplied with holes for fitting extra equipment.

Upper arm

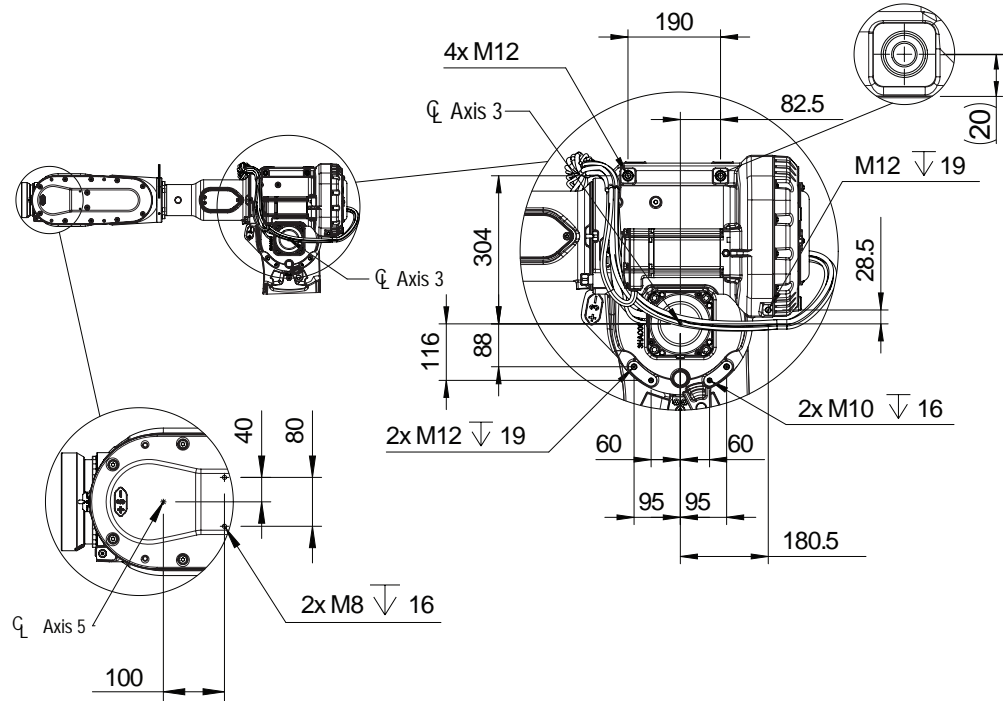

xx2100000810

Continues on next page

## 2 Technical data for IRB 5710

### 2.2 Fitting equipment on the robot (robot dimensions)

Continued

#### Lower arm

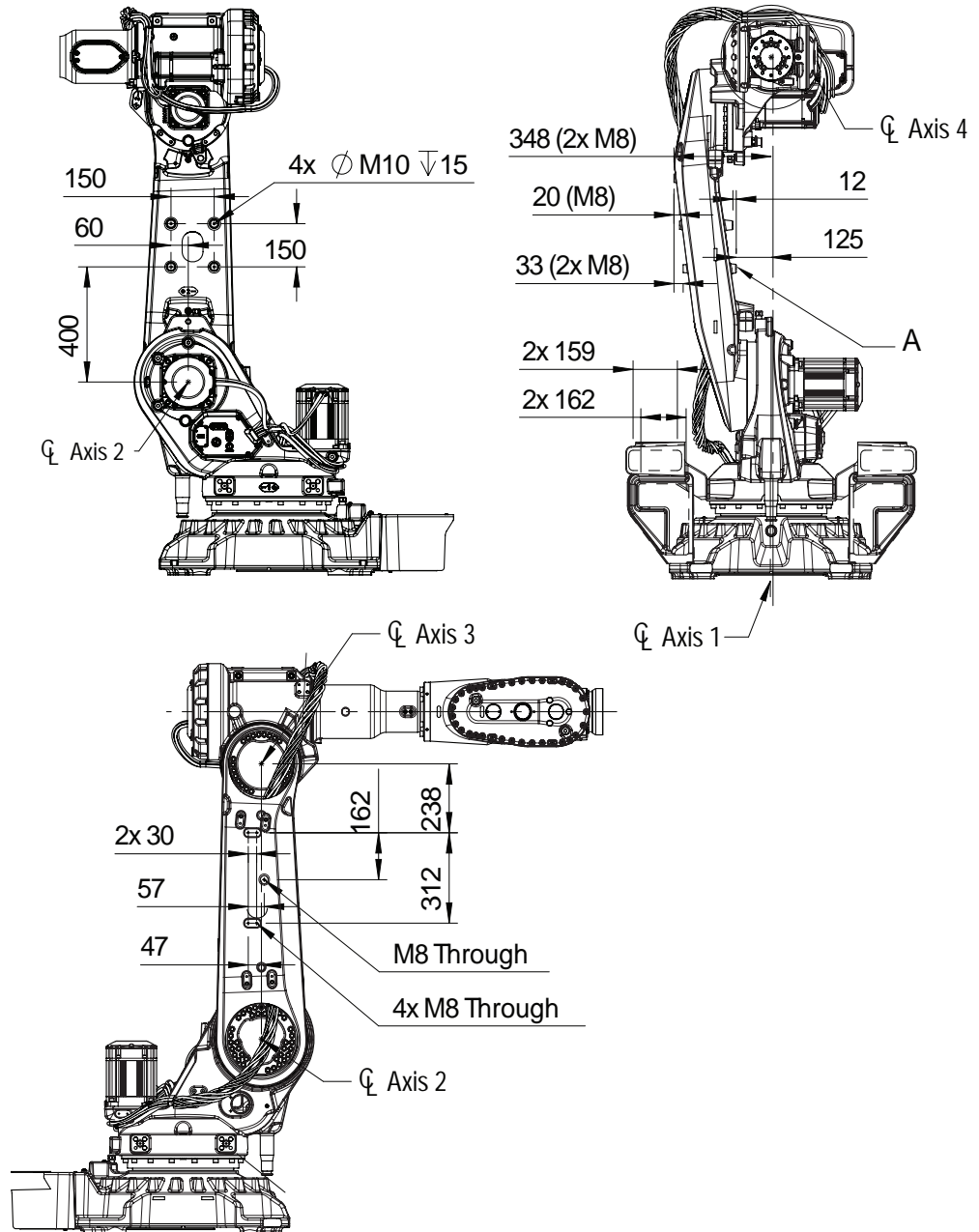

xx2100000811

A	<p>Allowed positions for attachment holes.          If no holes are present at delivery, they can be drilled at site: 4x M10 through.          Avoid damaging cables when drilling.</p>
---	---

Continues on next page

## 2 Technical data for IRB 5710

### 2.2 Fitting equipment on the robot (robot dimensions)

Continued

#### Frame

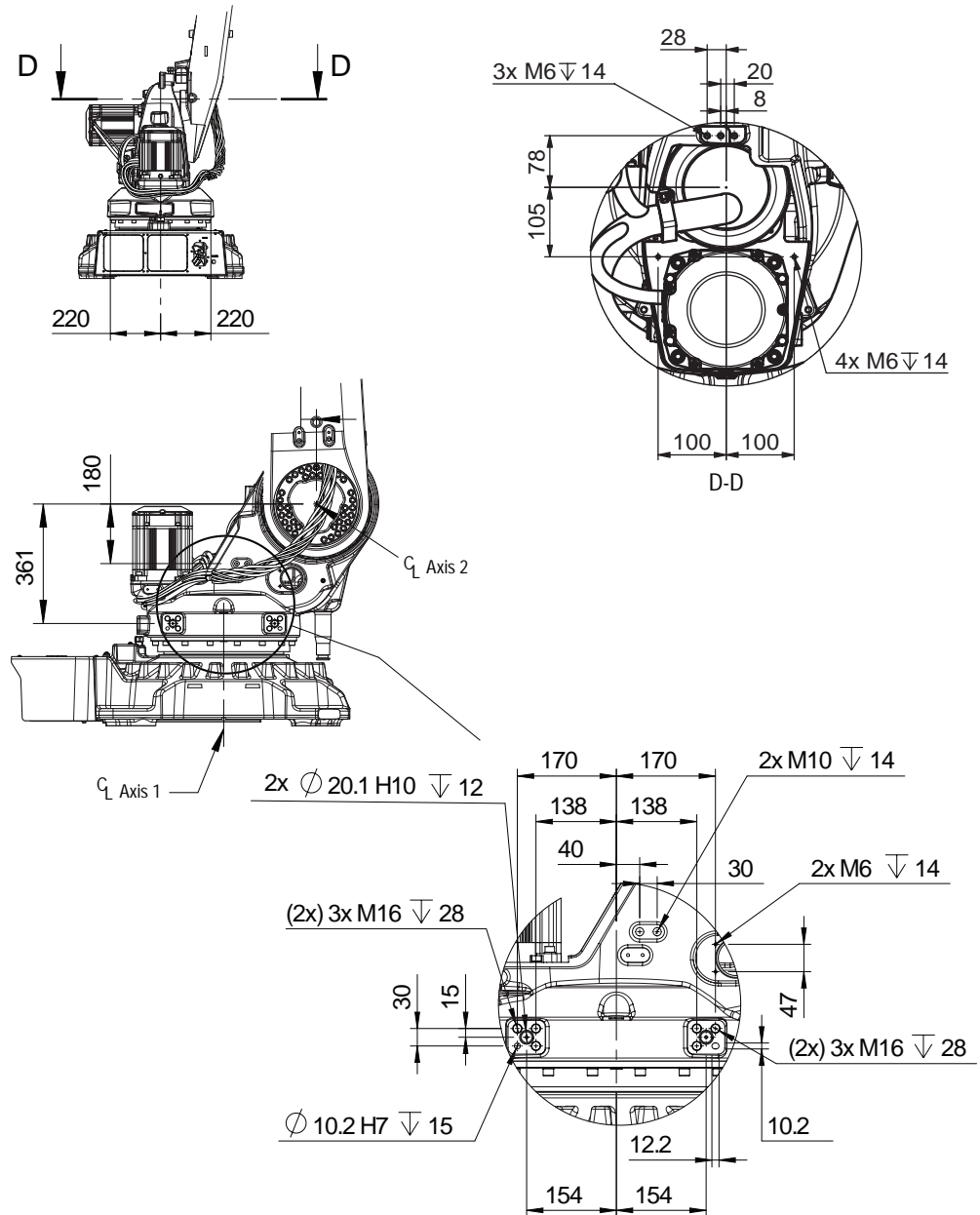

xx210000812

Continues on next page

## 2 Technical data for IRB 5710

### 2.2 Fitting equipment on the robot (robot dimensions)

Continued

#### Tool flange dimensions

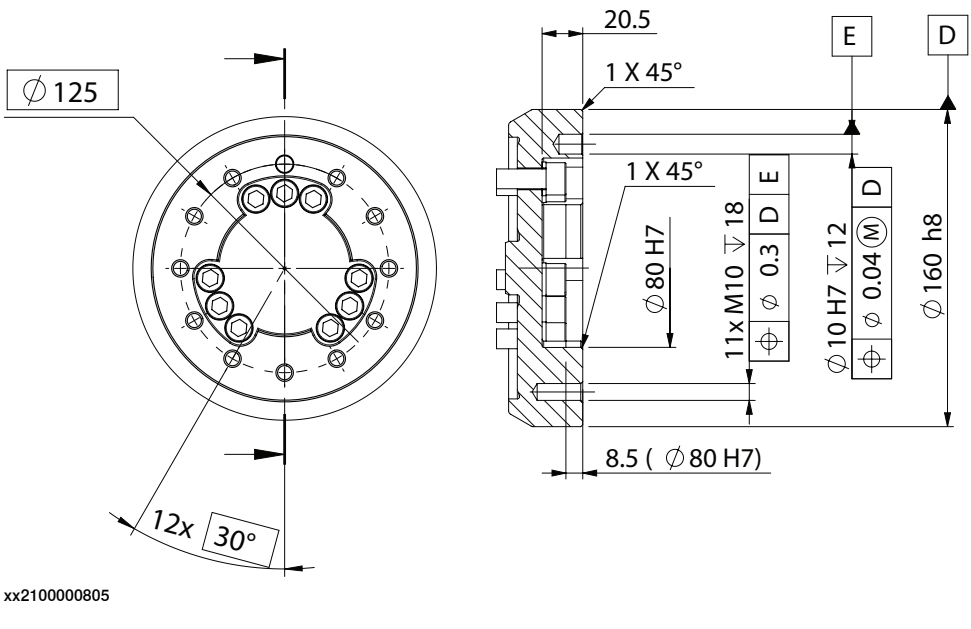
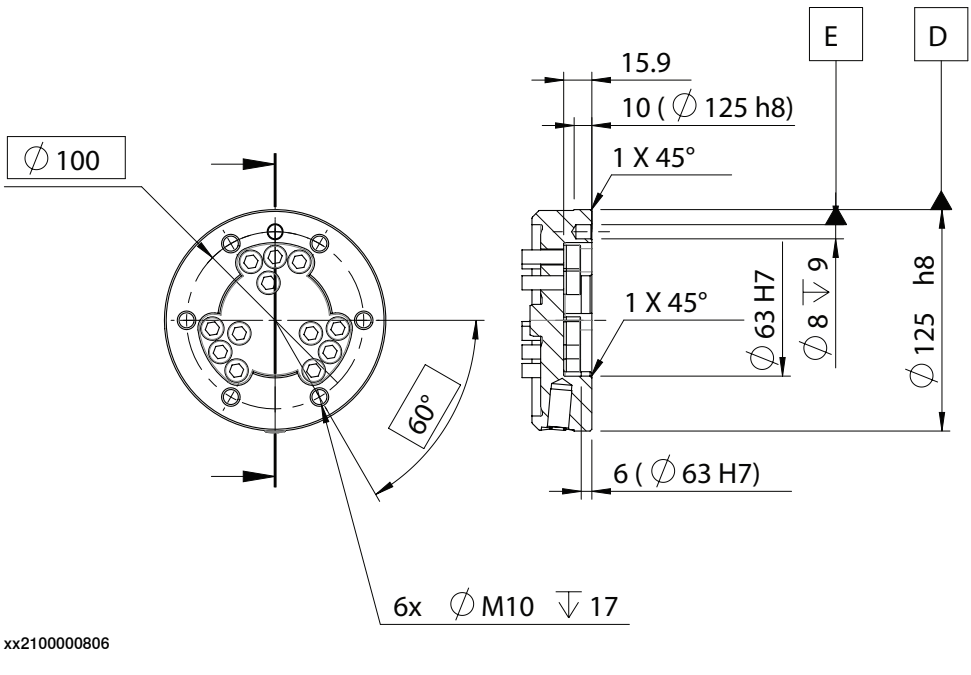
Robot variant	Tool flange dimension
IRB 5710-110/2.3   <p>xx2100000805</p>	 <p>xx2100000806</p>
IRB 5710-90/2.3 LID	

Continues on next page



## 2 Technical data for IRB 5710

### 2.2 Fitting equipment on the robot (robot dimensions)

Continued

Robot variant	Tool flange dimension
	<p>xx2100000807</p>
IRB 5710-70/2.7 LID	<p>xx2100000808</p>

#### Fastener quality

When fitting tools on the tool flange, only use screws with quality 12.9. For other equipment use suitable screws and tightening torque for your application.

## 2 Technical data for IRB 5710

---

### 2.3 Mechanical data for installation

### 2.3 Mechanical data for installation

---

#### Detailed installation instructions

All detailed installation instructions are found in *Product manual - IRB 5710*.

---

#### Attachment screws

The table below specifies the type of securing screws and washers to be used for securing the robot to the base plate/foundation.

Suitable screws	M24 x 100
Quantity	8 pcs
Quality	8.8
Suitable washer	4 mm flat washer
Guide pins	Guide pins are required if mounting the manipulator to a track motion or to a base plate. For more information, see <a href="#">Guide pins on page 48</a> .
Tightening torque	550 Nm (screws lubricated with Molykote 1000) 600-725 Nm, typical 650 Nm (screws none or lightly lubricated)
Screw tightening yield point utilization factor (v) (according to VDI2230)	90% (v=0.9)
Level surface requirements	0.3 mm <sup>i</sup>

<sup>i</sup> See [Requirements, foundation on page 19](#).

*Continues on next page*

Hole configuration, base

This illustration shows the hole configuration used when securing the robot.

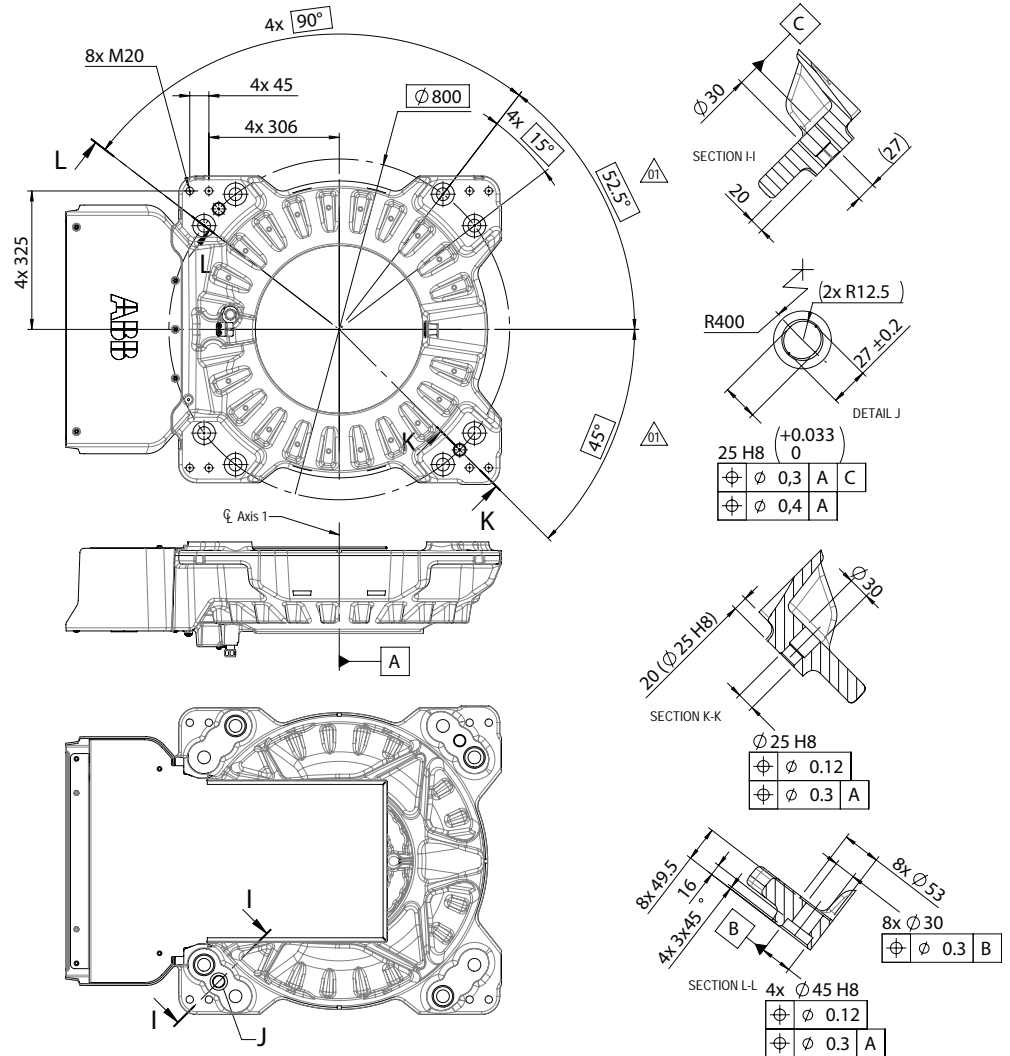

xx210000788

## 2 Technical data for IRB 5710

---

### 2.4 Installing a base plate

### 2.4 Installing a base plate

---

#### Advantages of using a base plate

Instead of installing the robot directly on the floor, a base plate can be manufactured and used as an adapter between the floor and the robot base. This list specifies some of the advantages of using a base plate:

- to ensure a plain surface with a high precision of the robot base hole configuration
- to simplify adjustment of levelness by machined surfaces or by using shims
- to distribute the press force from the robot to a larger foot print
- to compensate poor floor quality that might not be suitable for fastening the robot base directly onto. The base plate has a greater number of fastening points to the foundation and makes a larger footprint, which reduces the load on each fastening point.
- to reduce surface pressure on the foundation contact points, which minimizes the risk of wearing down an uneven surface and thereby causing changes in the robot fastening tightening torque
- to be able to prepare the installation site before robot delivery
- to increase the precision between the positions of an installed robot and other equipment



#### Note

Do not use a base plate for installation of an inverted robot.

*Continues on next page*

Base plate drawing

The following figure shows the option base plate (dimensions in mm).

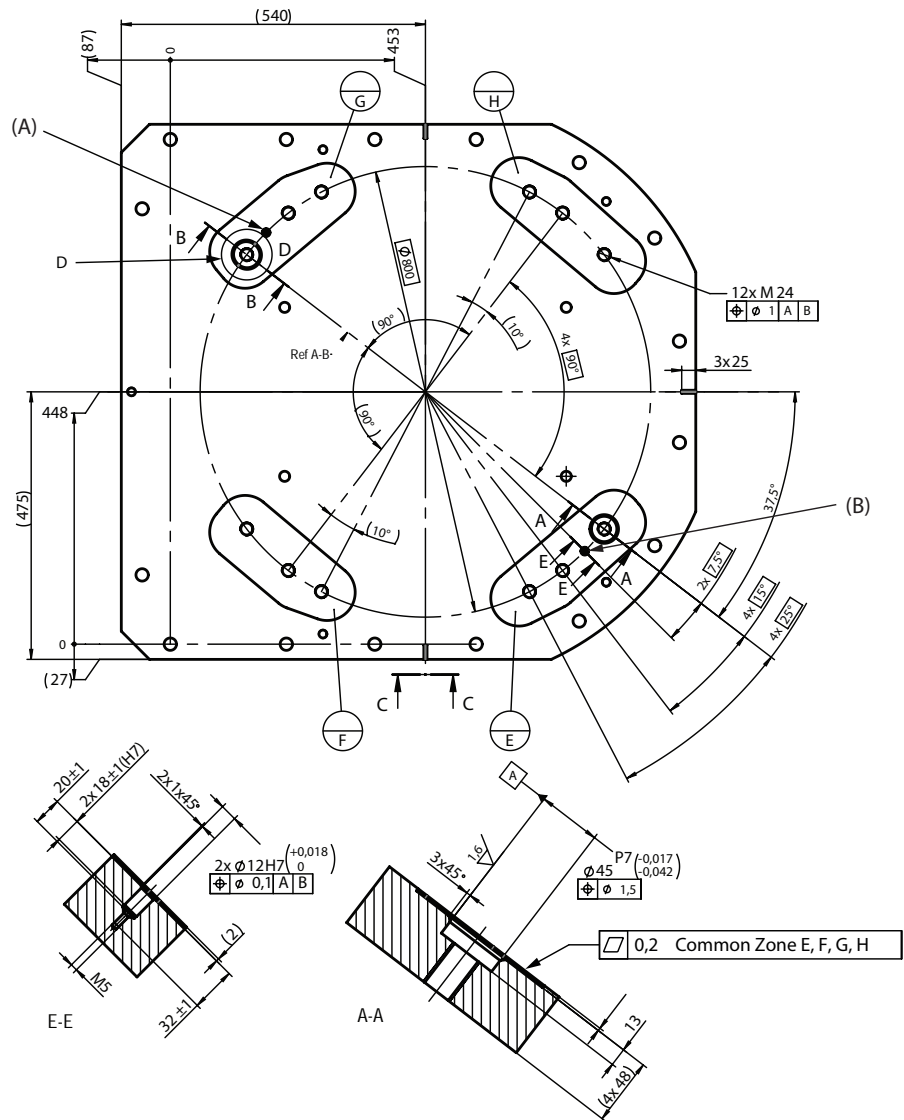

xx150000246

Pos	Description
A, B	Hole for guide pin, cylindrical, see <a href="#">Guide pins on page 48</a>
E, F, G, H	Common tolerance zone (accuracy all over the base plate from one contact surface to the other)

Continues on next page

## 2 Technical data for IRB 5710

### 2.4 Installing a base plate

Continued

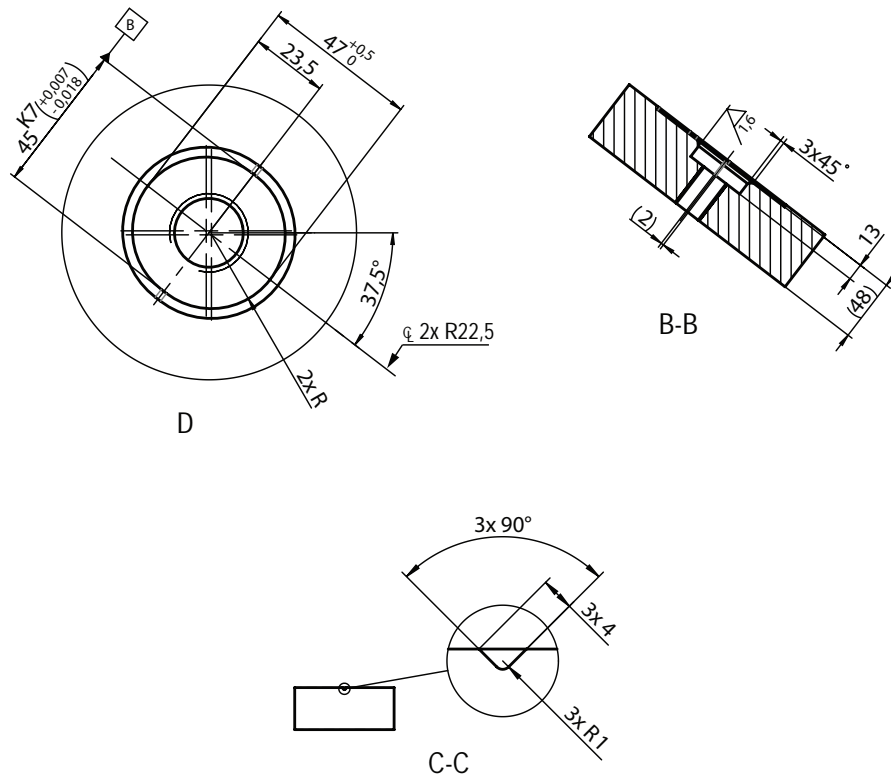

xx1500000247

Continues on next page

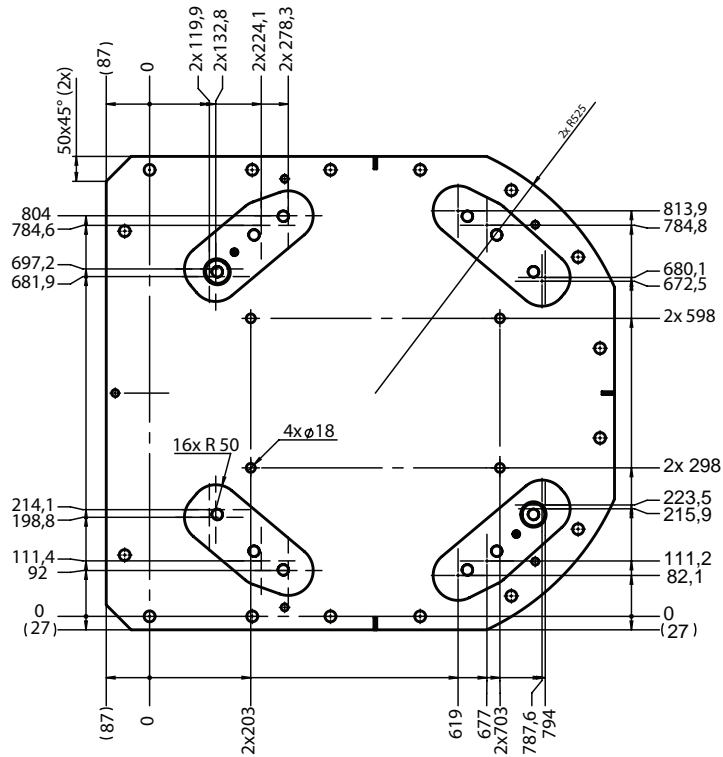
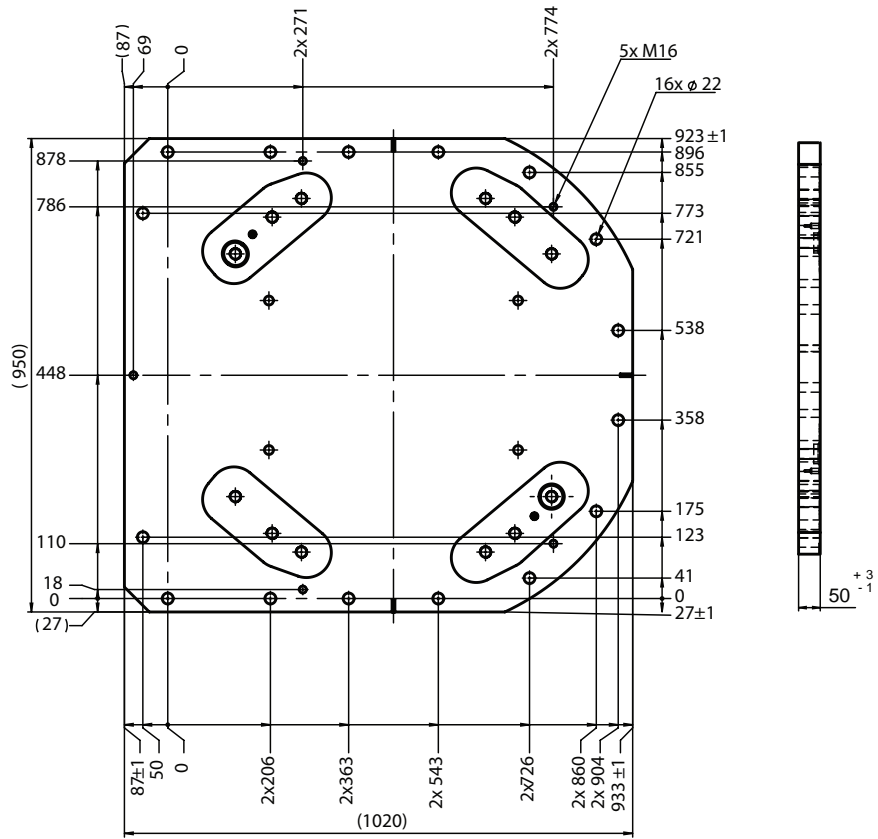

xx150000249

Continues on next page

## 2 Technical data for IRB 5710

### 2.4 Installing a base plate

Continued

#### Guide pins

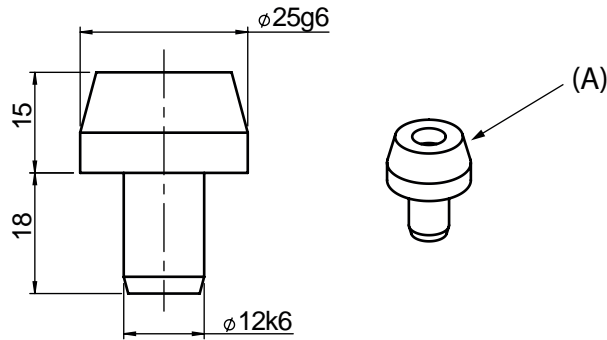

XX1500000248

Pos	Description
A	Cylindrical guide pin (x2) (Requires attachment screws, see <a href="#">Assembly of guide pins on page 48.</a> )

#### Assembly of guide pins

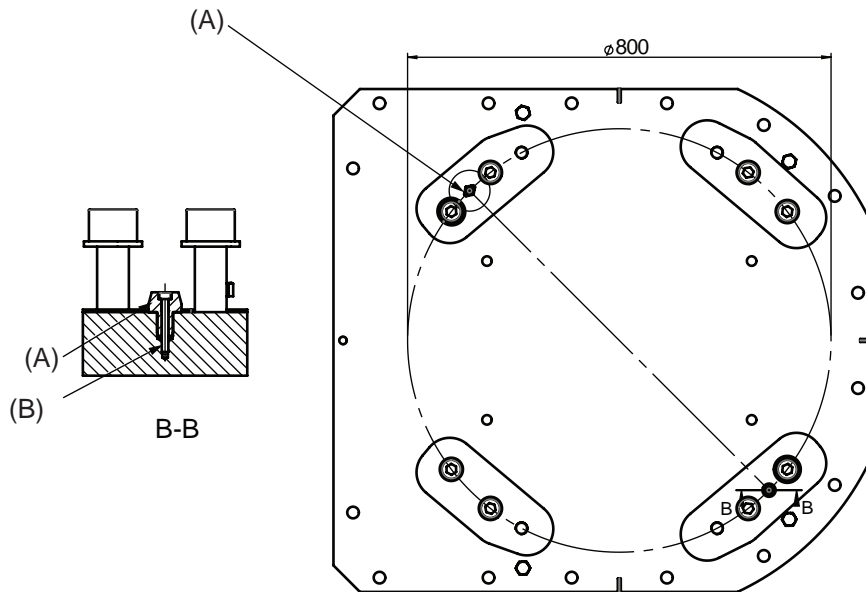

Pos	Description
A	Cylindrical guide pin (x2)
B	M5 x 40. Tightening torque 6 Nm. (x2)

Continues on next page



**Base plate, orienting grooves and leveling bolts**

The illustration below shows the orienting grooves and attachment holes for leveling bolts in the base plate.

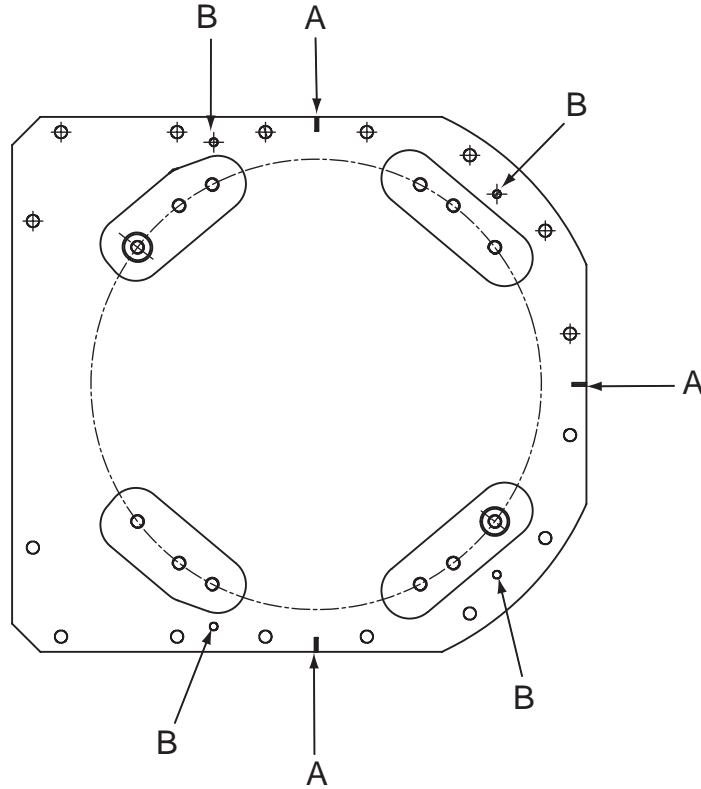

xx150000312

A	Orienting grooves (3 pcs)
B	Levelling bolts, attachment holes (4 pcs)

Continues on next page

## 2 Technical data for IRB 5710

### 2.4 Installing a base plate

Continued

#### Base plate, locating pins

The illustration below shows the locating pins in the base plate.

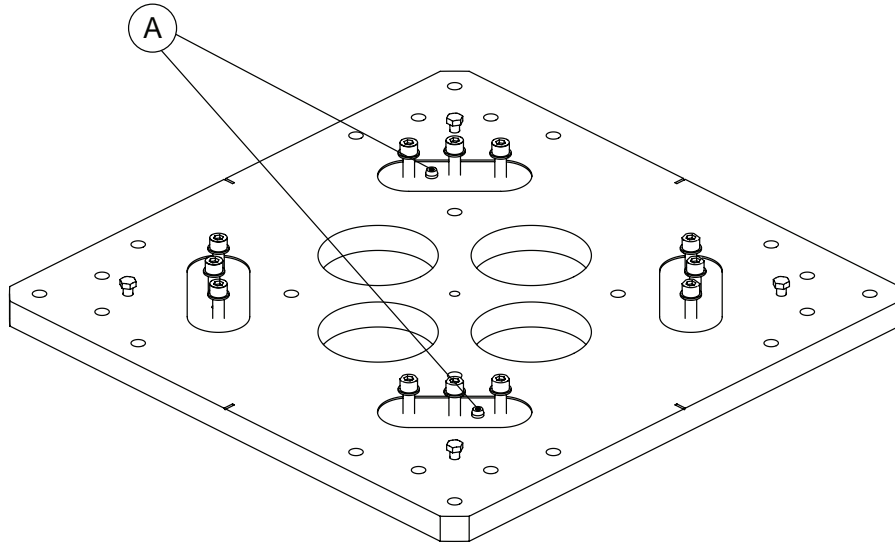

xx1700001591

A	Locating pins (2 pcs)
---	-----------------------

#### Base plate, guide sleeve holes

The illustration below shows the guide sleeve holes in the base plate.

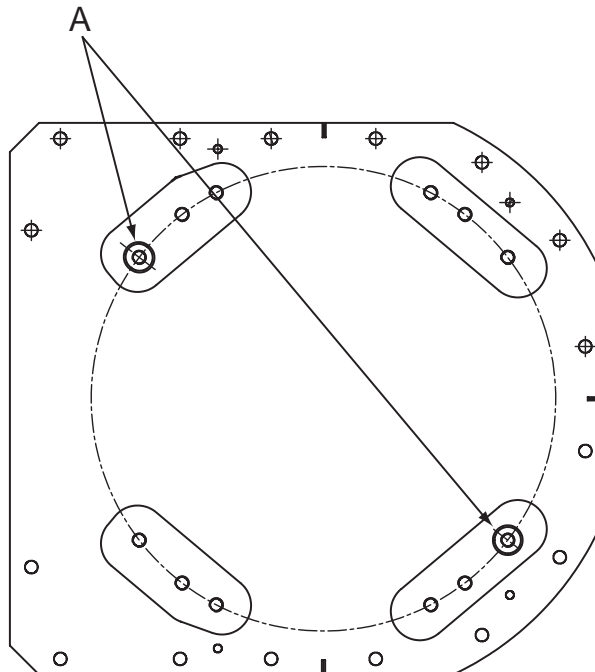

xx0300000045

A	Guide sleeve holes (2 pcs)
---	----------------------------

## 2.5 Setting the system parameters for an inverted or a tilted robot

### General

A robot delivered for inverted mounting, is configured for mounting parallel to the floor, without tilting. If the robot is mounted in any other angle than  $180^\circ$ , then the system parameters that describe the mounting angle (how the robot is oriented relative to the gravity) must be re-defined.



#### Note

With inverted installation, make sure that the gantry or corresponding structure is rigid enough to prevent unacceptable vibrations and deflections, so that optimum performance can be achieved.



#### Note

The mounting positions are described in [Mounting positions on page 17](#), and the requirements on the foundation are described in [Requirements, foundation on page 19](#).

### System parameters



#### Note

The mounting angle must be configured correctly in the system parameters so that the robot system can control the movements in the best possible way. An incorrect definition of the mounting angle will result in:

- Overloading the mechanical structure.
- Lower path performance and path accuracy.
- Some functions will not work properly, for example *Load Identification* and *Collision detection*.

### Gravity Beta

When the robot is mounted other than floor-standing (rotated around the y-axis), the robot base frame and the system parameter *Gravity Beta* must be redefined. If the robot is mounted upside down (inverted), then *Gravity Beta* should be  $\pi$  (+3.141593).

The *Gravity Beta* is a positive rotation direction around the y-axis in the base coordinate system. The value is set in radians.

### Gamma Rotation

*Gamma Rotation* defines the orientation of the robot foot on the travel carriage (track motion).

*Continues on next page*

## 2 Technical data for IRB 5710

---

### 2.5 Setting the system parameters for an inverted or a tilted robot

*Continued*

---

#### Mounting angles and values

The parameter *Gravity Beta* (or *Gravity Alpha*) specifies the mounting angle of the robot in radians. It is calculated in the following way.

$\text{Gravity Beta} = A^\circ \times 3.141593/180 = B \text{ radians}$ , where *A* is the mounting angle in degrees and *B* is the mounting angle in radians.

Example of position	Mounting angle (A °)	Gravity Beta
Floor mounted	0°	0.000000 (Default)
Tilted mounting	Example: 15°	Corresponds to: 0.261799 rad
Inverted mounting	180°	3.141593

---

#### Defining the system parameters in RobotWare

The value of the system parameters that define the mounting angle must be redefined when changing the mounting angle of the robot. The parameters belong to the type *Robot*, in the topic *Motion*.

The system parameters are described in *Technical reference manual - System parameters*.

The system parameters are configured in RobotStudio or on the FlexPendant.

## 2.6 Working range alterations

### 2.6.1 Adjusting the working range

#### Reasons for adjusting the manipulator working range

The working range of each manipulator axis is configured in the software. If there is a risk that the manipulator may collide with other objects at installation site, its working space should be limited. The manipulator must always be able to move freely within its entire working space.

#### Working range configurations

The parameter values for the axes working range can be altered within the allowed working range and according to available options for the robot, either to limit or to extend a default working range. Allowed working ranges and available options for each manipulator axis are specified in [Working range on page 28](#).

#### Mechanical stops on the manipulator

Mechanical stops are and can be installed on the manipulator as limiting devices to ensure that the manipulator axis does not exceed the working range values set in the software parameters.



#### Note

The mechanical stops are only installed as safety precaution to physically stop the robot from exceeding the working range set. A collision with a mechanical stop always requires actions for repair and troubleshooting.

Axis	Fixed mechanical stop <sup>i</sup>	Movable mechanical stop <sup>ii</sup>
Axis 1	yes	yes The working range can be reduced by altering the parameter values. Installation of additional mechanical stops is recommended. The working range can be extended (option 3324-1) by altering the parameter values and removing the movable mechanical stop pin.
Axis 2	yes	no
Axis 3	yes	no
Axis 4	no	no
Axis 5	yes	no
Axis 6	no	no

<sup>i</sup> Part of the casting or fixed on the casting and can not /should not be removed.

<sup>ii</sup> Can be installed in one or more than one position, to ensure a reduced working range, or be removed to allow extended working range.

## 2 Technical data for IRB 5710

### 2.6.2 Installing movable mechanical stops on axis 1 (option 3323-1)

### 2.6.2 Installing movable mechanical stops on axis 1 (option 3323-1)

#### Reduction of the axis-1 working range

The working range of axis 1 is limited by system parameter configuration. To reduce the working range from default range, first adjust the parameter values and then install additional mechanical stops as a safety measure.

The movable mechanical stops reduce the working range according to the table.

Graduation of limited working range	Reduction of working range
15°	from $\pm 5^\circ$ and $\pm 125^\circ$ in both directions

Illustration, reduced working range

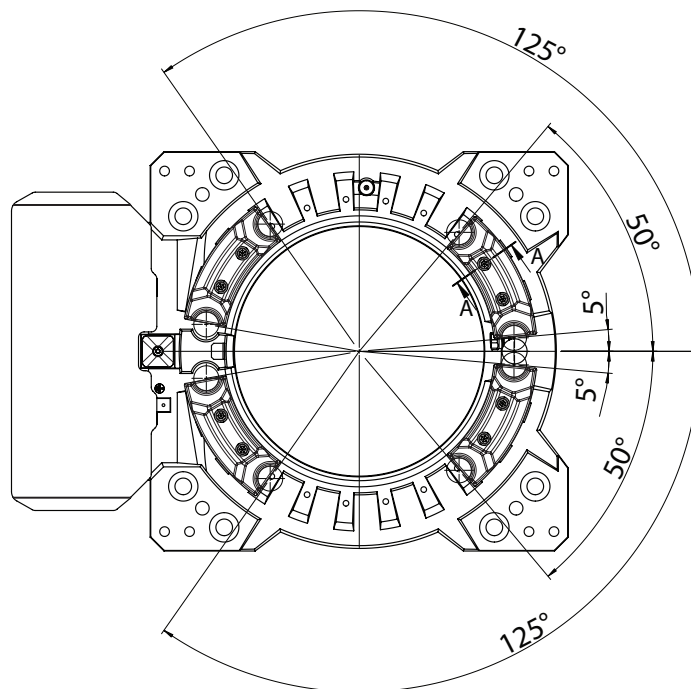

xx210000973



#### WARNING

If the mechanical stop pin is deformed after a hard collision, it must be replaced!  
Deformed movable stops and/or additional stops as well as deformed attachment screws must also be replaced after a hard collision.

*Continues on next page*

**Location of the mechanical stops**

The mechanical stops are located as shown in the figure.

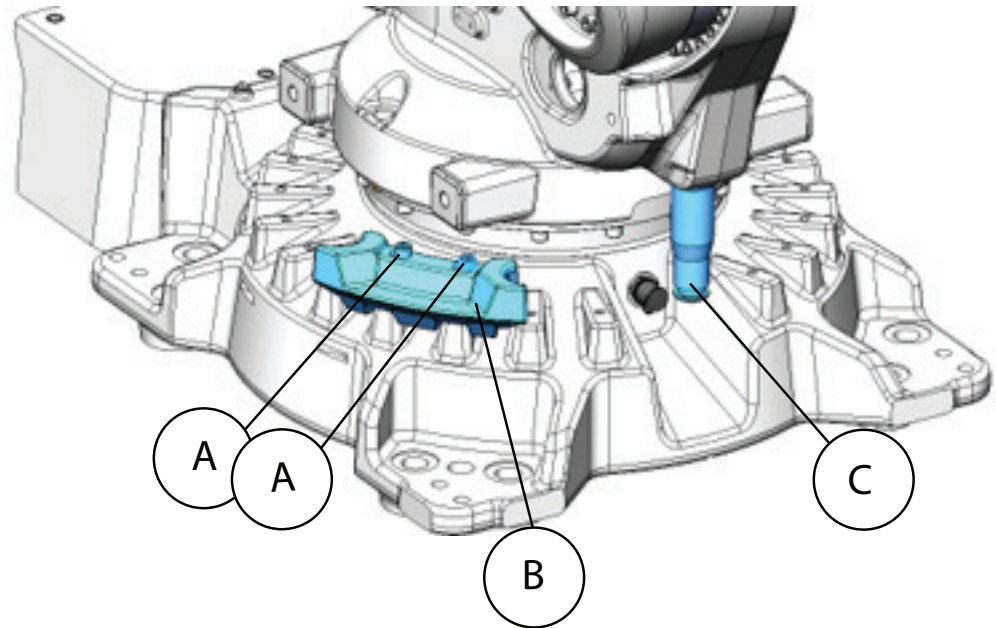

xx2100002647

A <sup>i</sup>	Attachment screws M12x70 quality 12.9 and washers DIN 125 (2 pcs per additional mechanical stop); Tightening torque 60 Nm
B	Movable mechanical stop
C	Mechanical stop pin axis-1

<sup>i</sup> There is a need to drill and make threaded M12 holes in base.  
Use the movable mechanical stop or the dents in the casting as a guide to drill.

**Installing the movable mechanical stops**

See the product manual for installation procedure.

## 2 Technical data for IRB 5710

### 2.7.1 Calibration methods

## 2.7 Calibration and references

### 2.7.1 Calibration methods

#### Overview

This section specifies the different types of calibration and the calibration methods that are supplied by ABB.

The original calibration data delivered with the robot is generated when the robot is floor mounted. If the robot is not floor mounted, then the robot accuracy could be affected. The robot needs to be calibrated after it is mounted.

More information is available in the product manual.

#### Types of calibration

Type of calibration	Description	Calibration method
Standard calibration	The calibrated robot is positioned at calibration position. Standard calibration data is found on the SMB (serial measurement board) or EIB in the robot.	Axis Calibration
Absolute accuracy calibration (optional)	Based on standard calibration, and besides positioning the robot at synchronization position, the Absolute accuracy calibration also compensates for: <ul style="list-style-type: none"><li>Mechanical tolerances in the robot structure</li><li>Deflection due to load</li></ul> Absolute accuracy calibration focuses on positioning accuracy in the Cartesian coordinate system for the robot. Absolute accuracy calibration data is found on the serial measurement board (SMB) or other robot memory. A robot calibrated with Absolute accuracy has the option information printed on its name plate (OmniCore). To regain 100% Absolute accuracy performance, the robot must be recalibrated for absolute accuracy after repair or maintenance that affects the mechanical structure.	CalibWare

#### Brief description of calibration methods

##### Axis Calibration method

Axis Calibration is a standard calibration method for calibration of IRB 5710. It is the recommended method in order to achieve proper performance.

The following routines are available for the Axis Calibration method:

- Fine calibration
- Update revolution counters
- Reference calibration

The calibration equipment for Axis Calibration is delivered as a toolkit.

*Continues on next page*



The actual instructions of how to perform the calibration procedure and what to do at each step is given on the FlexPendant. You will be guided through the calibration procedure, step by step.

#### CalibWare - Absolute Accuracy calibration

The CalibWare tool guides through the calibration process and calculates new compensation parameters. This is further detailed in the *Application manual - CalibWare Field*.

If a service operation is done to a robot with the option Absolute Accuracy, a new absolute accuracy calibration is required in order to establish full performance. For most cases after replacements that do not include taking apart the robot structure, standard calibration is sufficient.

The Absolute Accuracy option varies according to the robot mounting position. This is printed on the robot name plate for each robot. The robot must be in the correct mounting position when it is recalibrated for absolute accuracy.

## 2 Technical data for IRB 5710

### 2.7.2 Synchronization marks and synchronization position for axes

### 2.7.2 Synchronization marks and synchronization position for axes

#### Introduction

This section shows the position of the synchronization marks and the synchronization position for each axis.

#### Synchronization marks, IRB 5710, IRB 5720

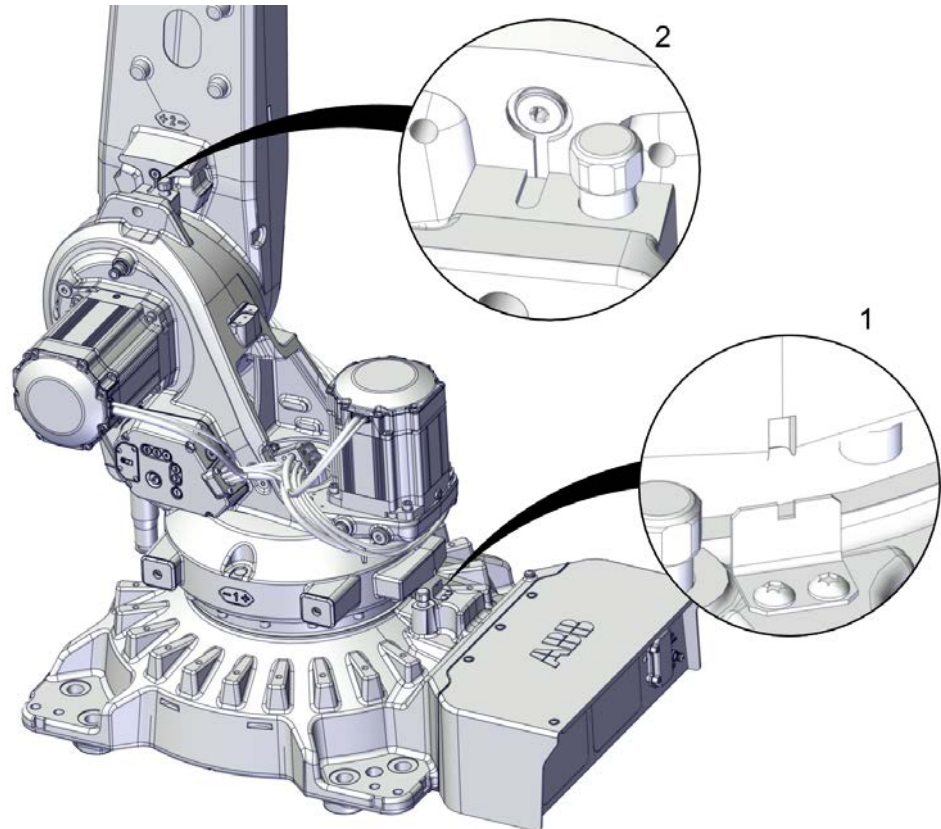

xx2100002319

*Continues on next page*

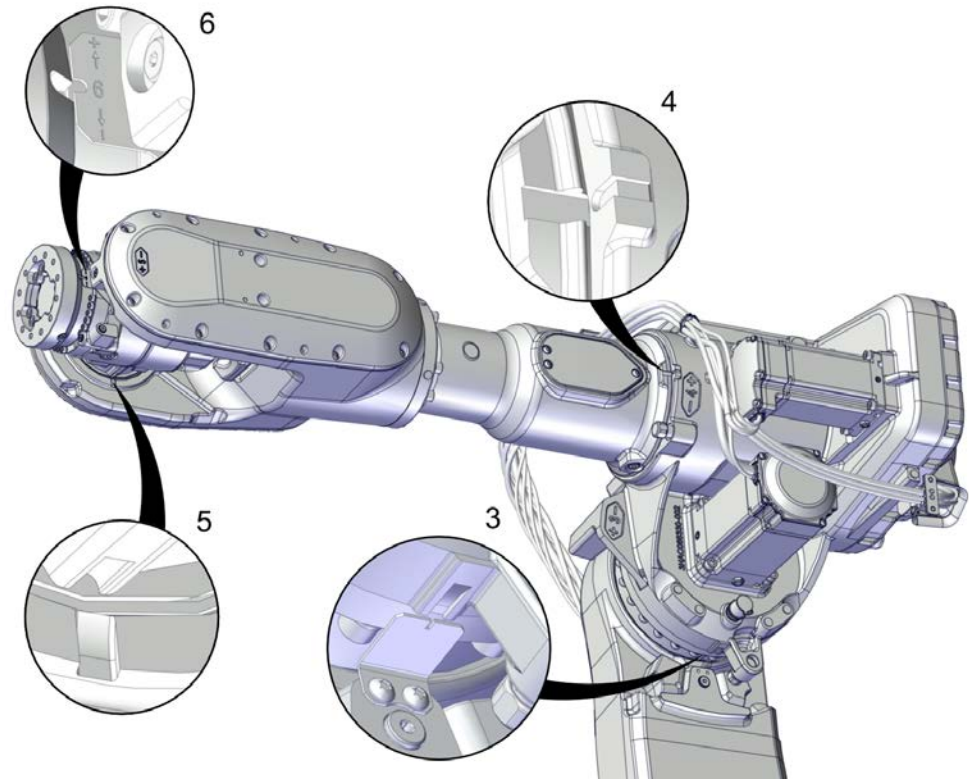

xx2100002318

## 2 Technical data for IRB 5710

### 2.7.3 Calibration movement directions for all axes

### 2.7.3 Calibration movement directions for all axes

#### Overview

When calibrating, the axis must consistently be run towards the calibration position in the same direction in order to avoid position errors caused by backlash in gears and so on. Positive directions are shown in the graphic below.

Calibration service routines will handle the calibration movements automatically and these might be different from the positive directions shown below.

#### Manual movement directions

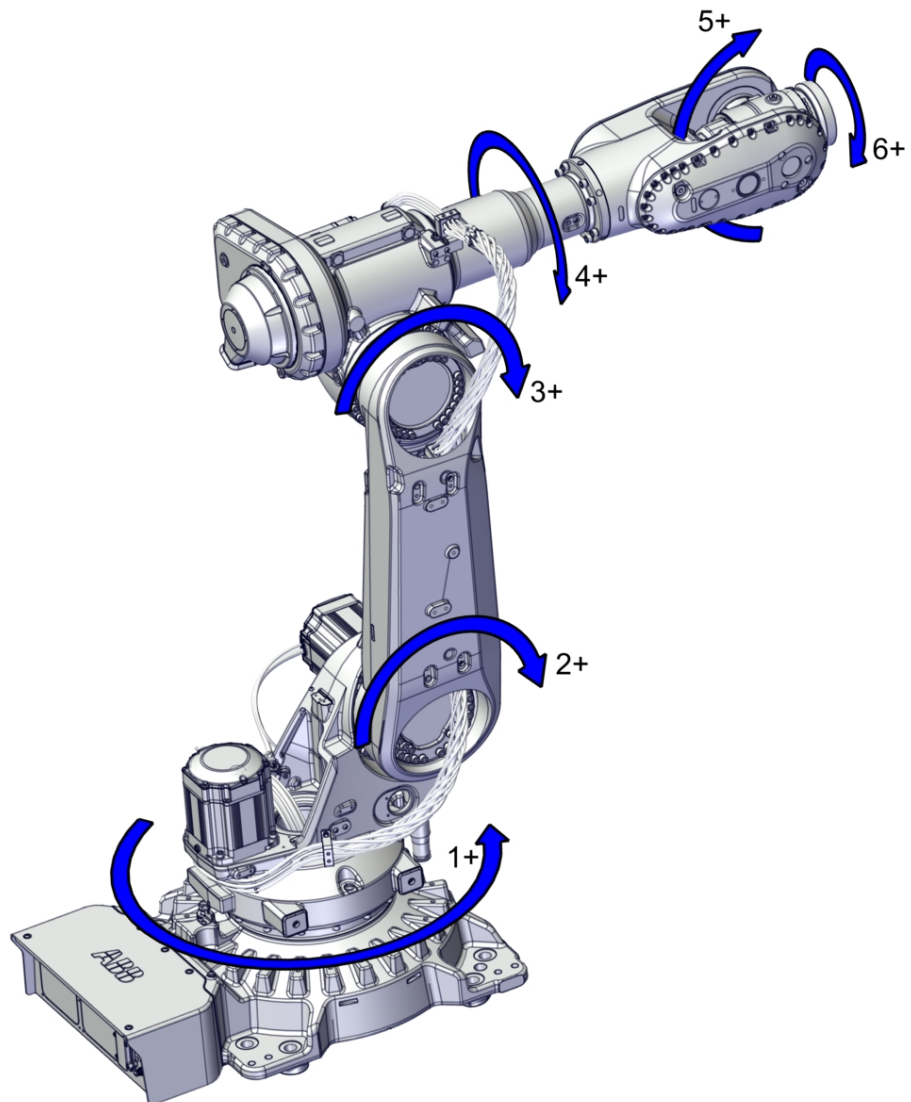

xx2100002527

## 2.7.4 Fine calibration

### Recommended method

Fine calibration for the IRB 5710 is done with the Axis Calibration method.

### Installation locations for the calibration tools

The figure shows the locations for the fixed calibration pins and/or bushings on each axis. Installed calibration tools are not shown.

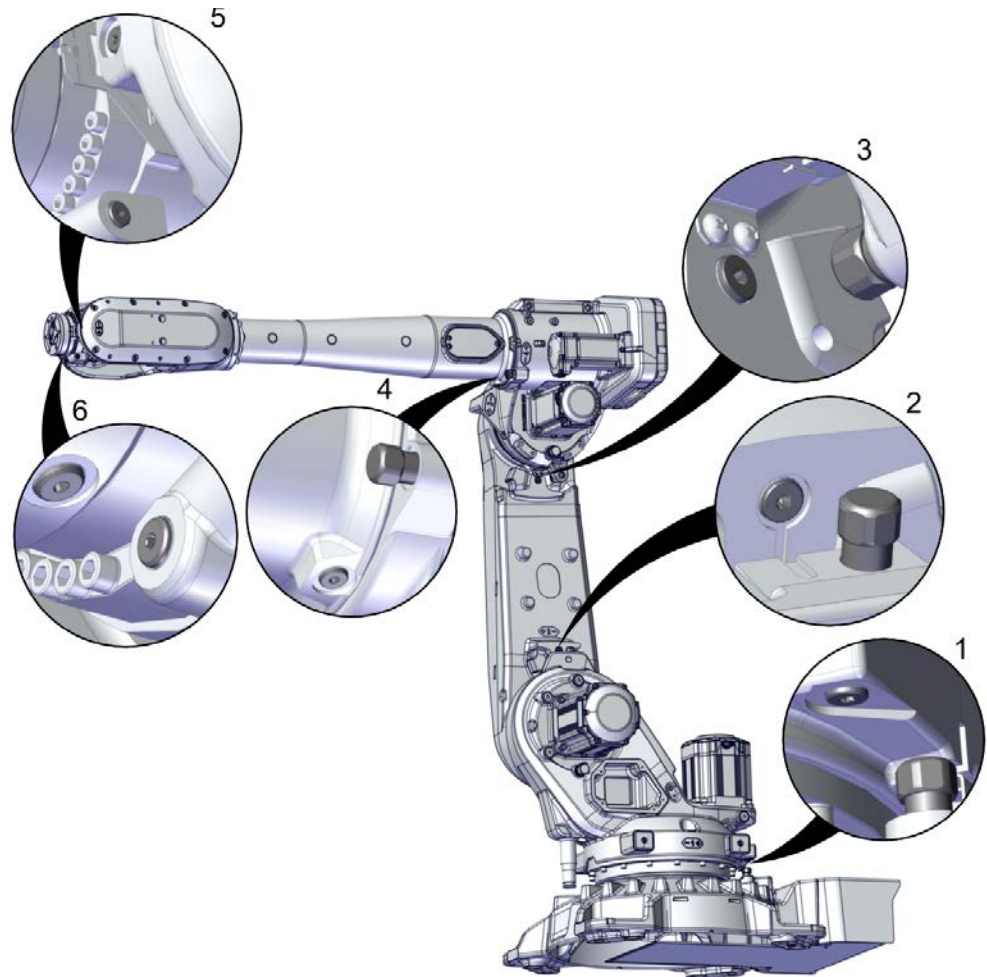

xx2100002320

More information about the Axis Calibration method is found in the product manual for the manipulator.

## 2 Technical data for IRB 5710

### 2.7.5 Axis calibration on axis 6

#### 2.7.5 Axis calibration on axis 6

##### General

Consideration of the customer tool design is required to be able to perform calibration with the tool fitted on the robot. The tool can enclose the outside of the turning disc if it is not thicker than 10 mm (radial distance) in the position where preparation is done.



##### Note

Space needed to mount the calibration tool for IRB 5710-90/2.7.

##### Customer interface plane

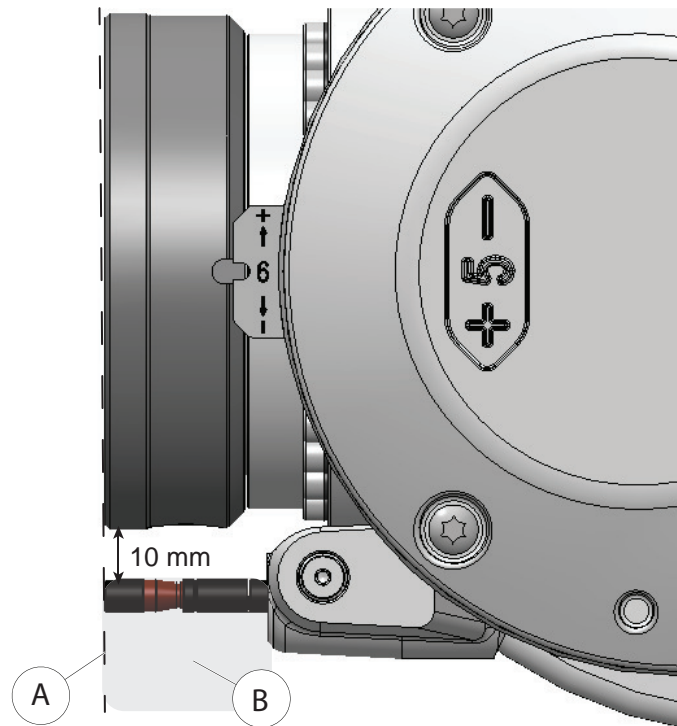

xx2100001145

Position	Description
A	Customer interface plane
B	Space needed to mount the calibration tool

*Continues on next page*

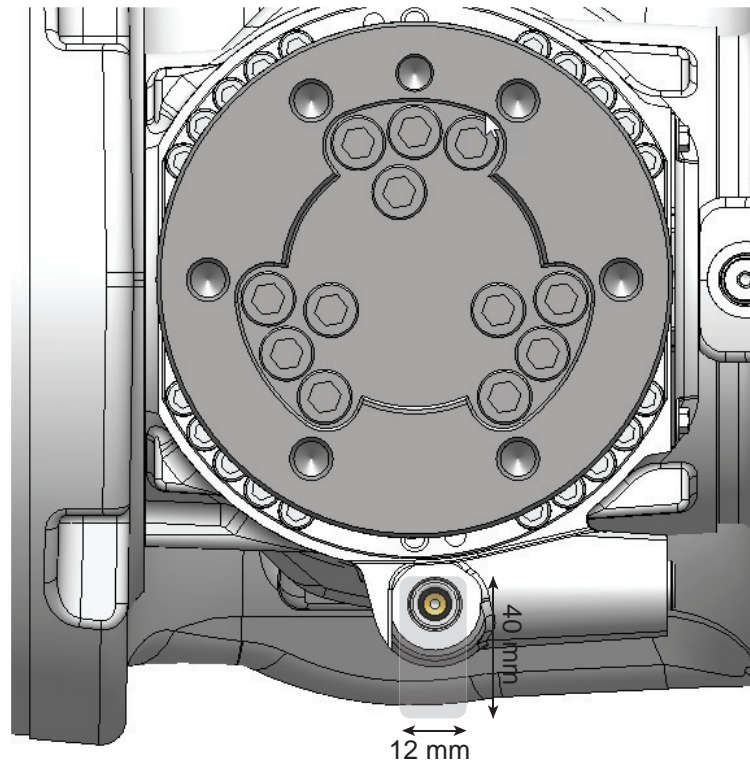

xx2100001146

## 2 Technical data for IRB 5710

### 2.7.6 Calibration tools for Axis Calibration

#### 2.7.6 Calibration tools for Axis Calibration

##### Calibration tools



#### WARNING

If any part is missing or damaged, the tool must be replaced immediately.

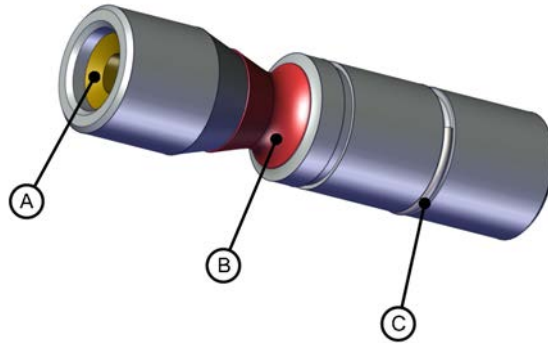

xx1500001914

A	Tube insert
B	Plastic protection
C	Steel spring ring

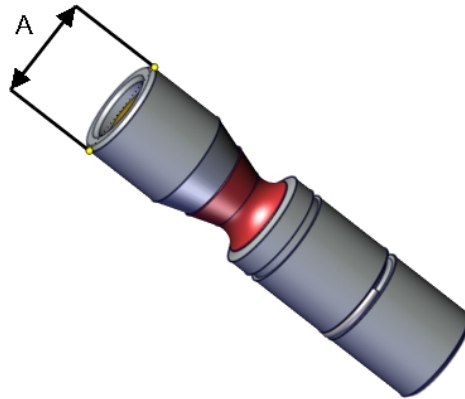

xx1500000951

A	Outer diameter
---	----------------

If including the calibration tool in a local periodic check system, the following measures should be checked.

- Outer diameter within  $\varnothing 12g4$  mm,  $\varnothing 8g4$  mm or  $\varnothing 6g5$  mm (depending on calibration tool size).
- Straightness within 0.005 mm.



### 2.7.7 Absolute Accuracy calibration

#### Purpose

*Absolute Accuracy* is a calibration concept that improves TCP accuracy. The difference between an ideal robot and a real robot can be several millimeters, resulting from mechanical tolerances and deflection in the robot structure. *Absolute Accuracy* compensates for these differences.

Here are some examples of when this accuracy is important:

- Exchangeability of robots
- Offline programming with no or minimum touch-up
- Online programming with accurate movement and reorientation of tool
- Programming with accurate offset movement in relation to eg. vision system or offset programming
- Re-use of programs between applications

The option *Absolute Accuracy* is integrated in the controller algorithms and does not need external equipment or calculation.



#### Note

The performance data is applicable to the corresponding RobotWare version of the individual robot.

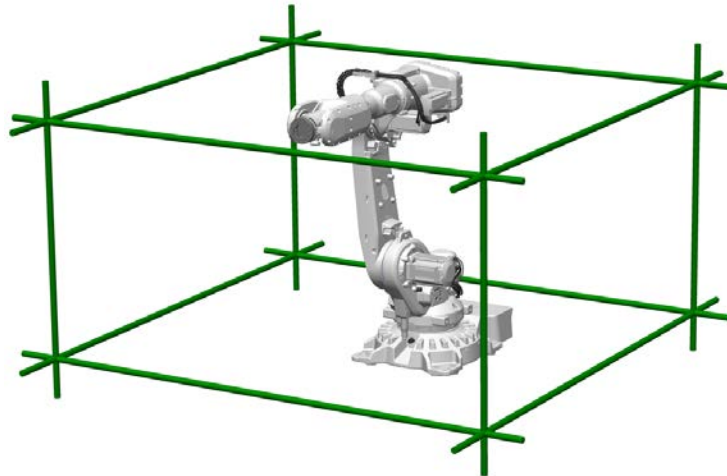

xx2100002472

#### What is included

Every *Absolute Accuracy* robot is delivered with:

- compensation parameters saved on the robot's serial measurement board
- a birth certificate representing the *Absolute Accuracy* measurement protocol for the calibration and verification sequence.

A robot with *Absolute Accuracy* calibration has a label with this information on the manipulator.

*Continues on next page*

## 2 Technical data for IRB 5710

---

### 2.7.7 Absolute Accuracy calibration

*Continued*

Absolute Accuracy supports floor mounted installations. Compensation parameters saved in the robot's serial measurement board differ depending on which Absolute Accuracy option is selected.

---

#### **RAPID instructions**

There are no RAPID instructions included in this option.

## 2.8 Load diagrams

### 2.8.1 Introduction



#### WARNING

It is very important to always define correct actual load data and correct payload of the robot. Incorrect definitions of load data can result in overloading of the robot.

If incorrect load data and/or loads are outside load diagram is used the following parts can be damaged due to overload:

- motors
- gearboxes
- mechanical structure
- controller drive system



#### WARNING

In the robot system the service routine LoadIdentify is available, which allows the user to make an automatic definition of the tool and load, to determine correct load parameters.

See *Operating manual - OmniCore*, for detailed information.



#### WARNING

Robots running with incorrect load data and/or with loads outside diagram, will not be covered by robot warranty.

### Nominal payload inertia and extra load

The load diagram for each robot variant includes a nominal payload inertia ( $J_0$ ), as specified in the table.

Robot variant	Nominal payload inertia, $J_0$	Extra load
IRB 5710-110/2.3, IRB 5710-90/2.7	10 kgm <sup>2</sup>	20 kg
IRB 5710-90/2.3 LID, IRB 5710-70/2.7 LID	10 kgm <sup>2</sup>	LeanID SW

At different moment of inertia the load diagram will be changed.

For robots that are allowed floor, tilted or inverted mounted, the load diagrams as given are valid and thus it is also possible to use RobotLoad within those tilt and axis limits.

*Continues on next page*

## 2 Technical data for IRB 5710

---

### 2.8.1 Introduction

*Continued*

---

#### **Control of load case by "RobotLoad"**

To verify a specific load case, use the RobotStudio add-in RobotLoad.

The result from RobotLoad is only valid within the maximum loads and tilt angles. There is no warning if the maximum permitted arm load is exceeded. For over-load cases and special applications, contact ABB for further analysis.

2.8.2 Diagrams

Diagrams of IRB 5710-110/2.3

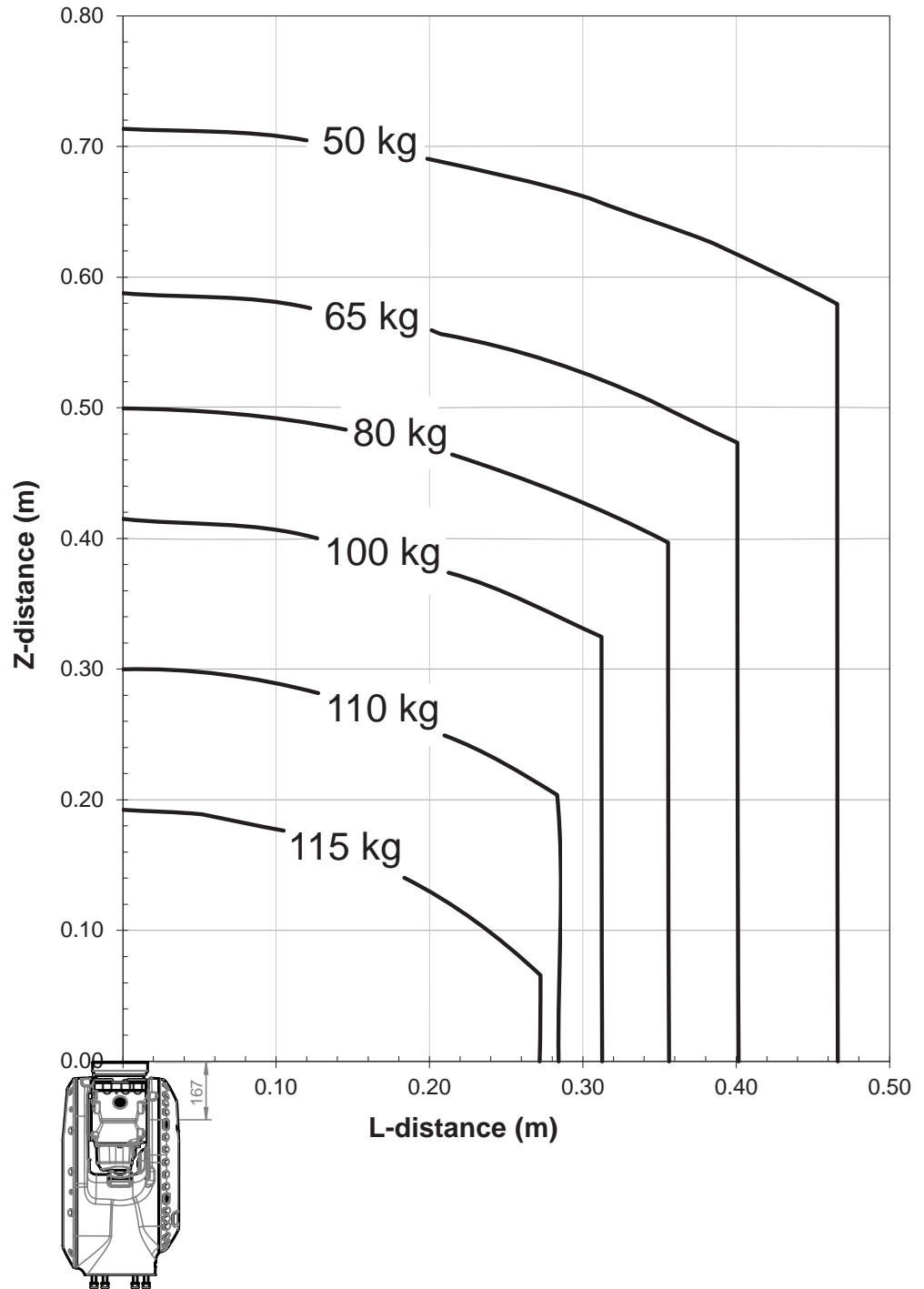

xx2100001496

Continues on next page

## 2 Technical data for IRB 5710

### 2.8.2 Diagrams

Continued

#### Diagrams of IRB 5710-110/2.3"Vertical Wrist" ( $\pm 10^\circ$ )

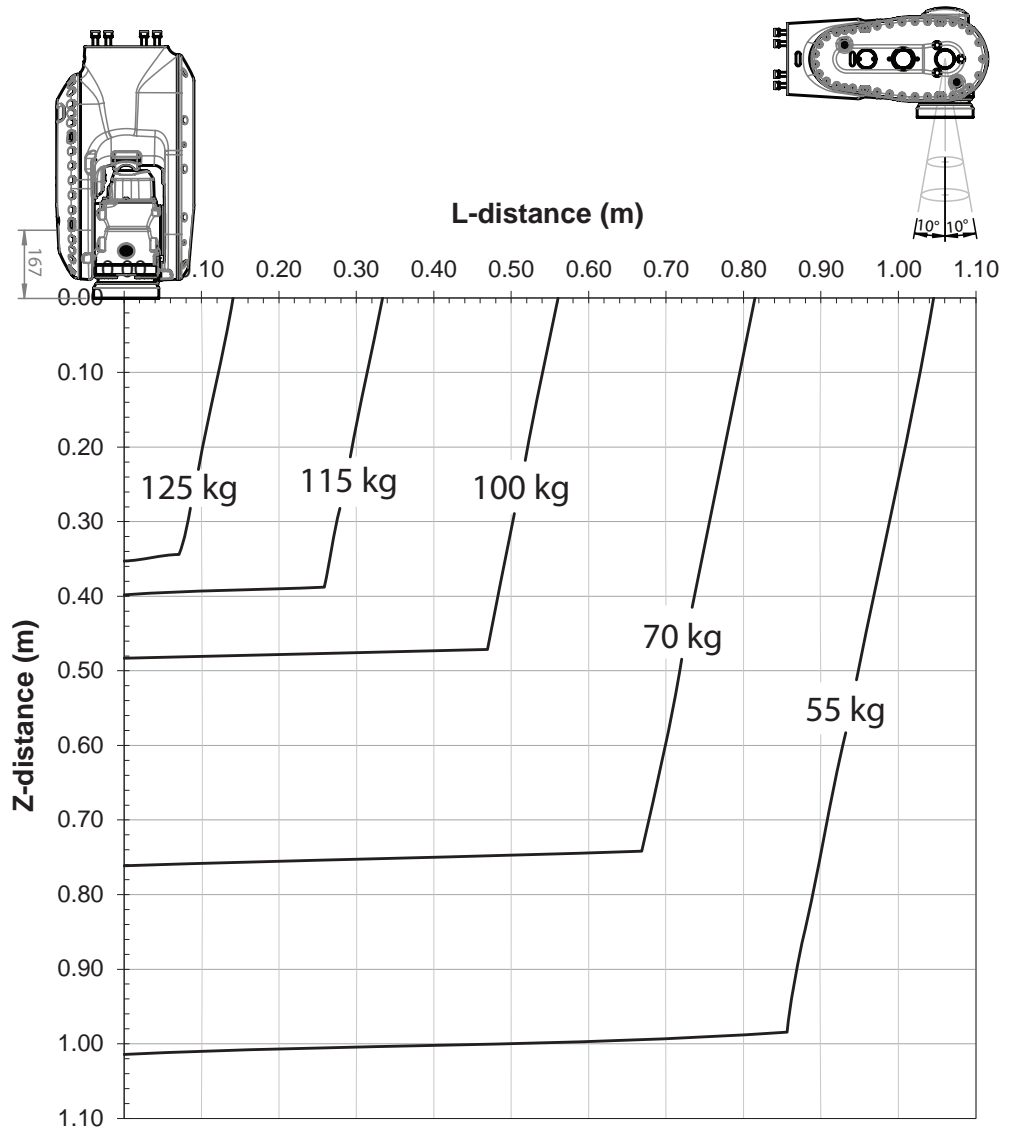

xx2100001497

For wrist down ( $0^\circ$  deviation from the vertical line).

	Description
Max load	145 kg
Z <sub>max</sub>	0.281 m
L <sub>max</sub>	0.053 m

Continues on next page

Diagrams of IRB 5710-90/2.7

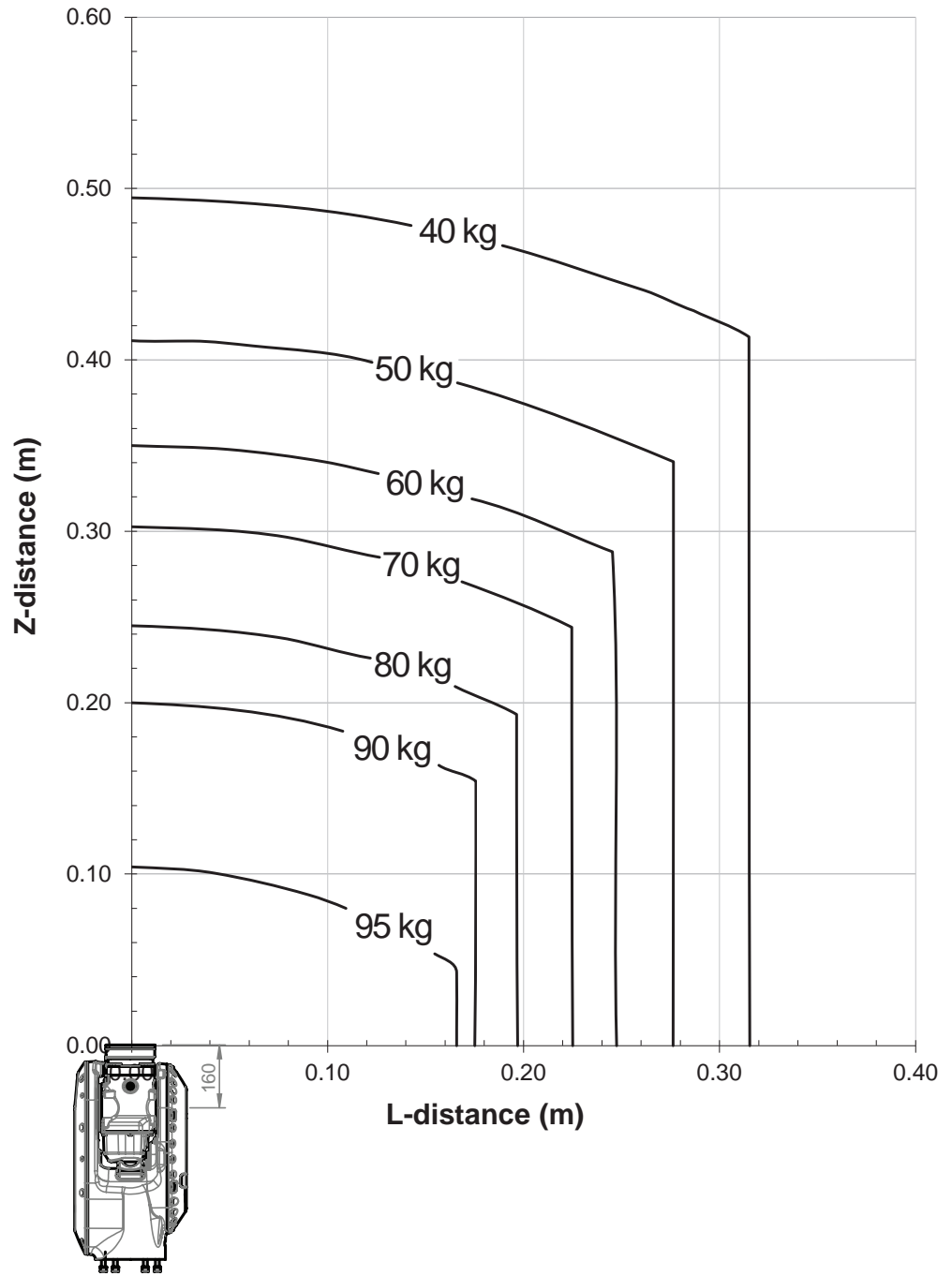

xx2100001500

Continues on next page

## 2 Technical data for IRB 5710

### 2.8.2 Diagrams

Continued

#### Diagrams of IRB 5710-90/2.7"Vertical Wrist" ( $\pm 10^\circ$ )

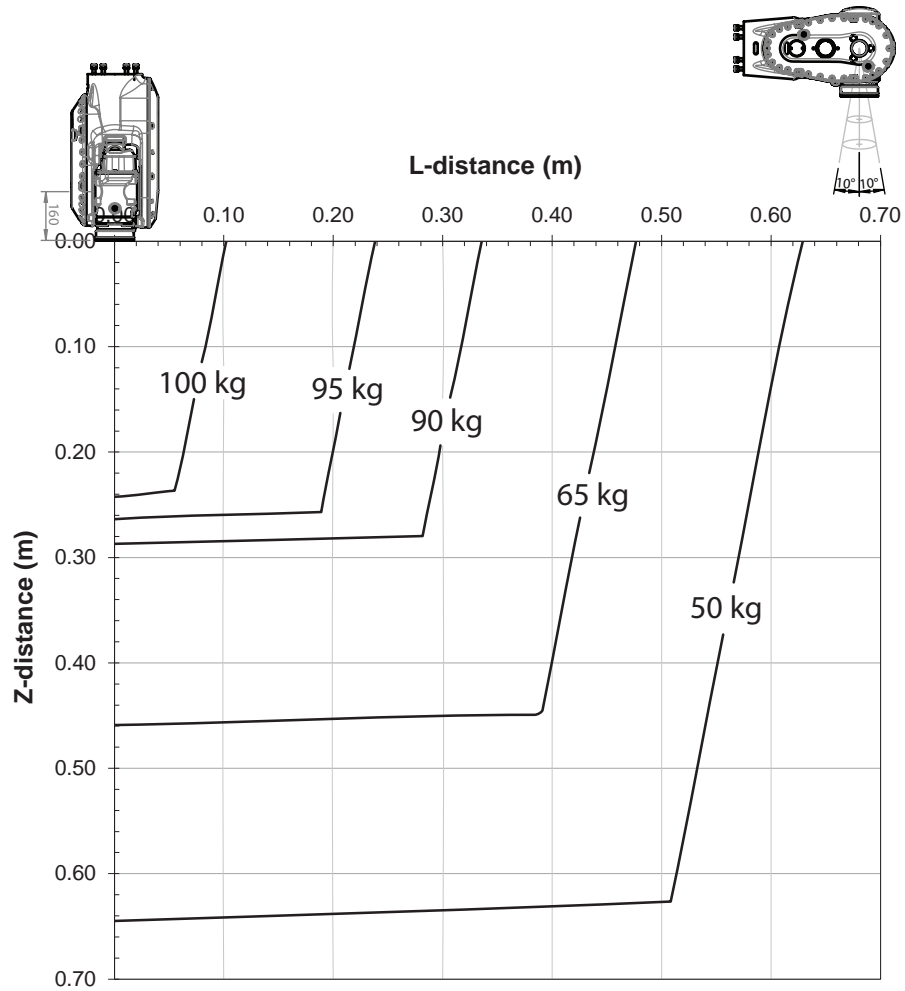

xx2100001501

For wrist down ( $0^\circ$  deviation from the vertical line).

	Description
Max load	112 kg
Z <sub>max</sub>	0.199 m
L <sub>max</sub>	0.068 m

Continues on next page



Diagrams of IRB 5710-90/2.3 LID

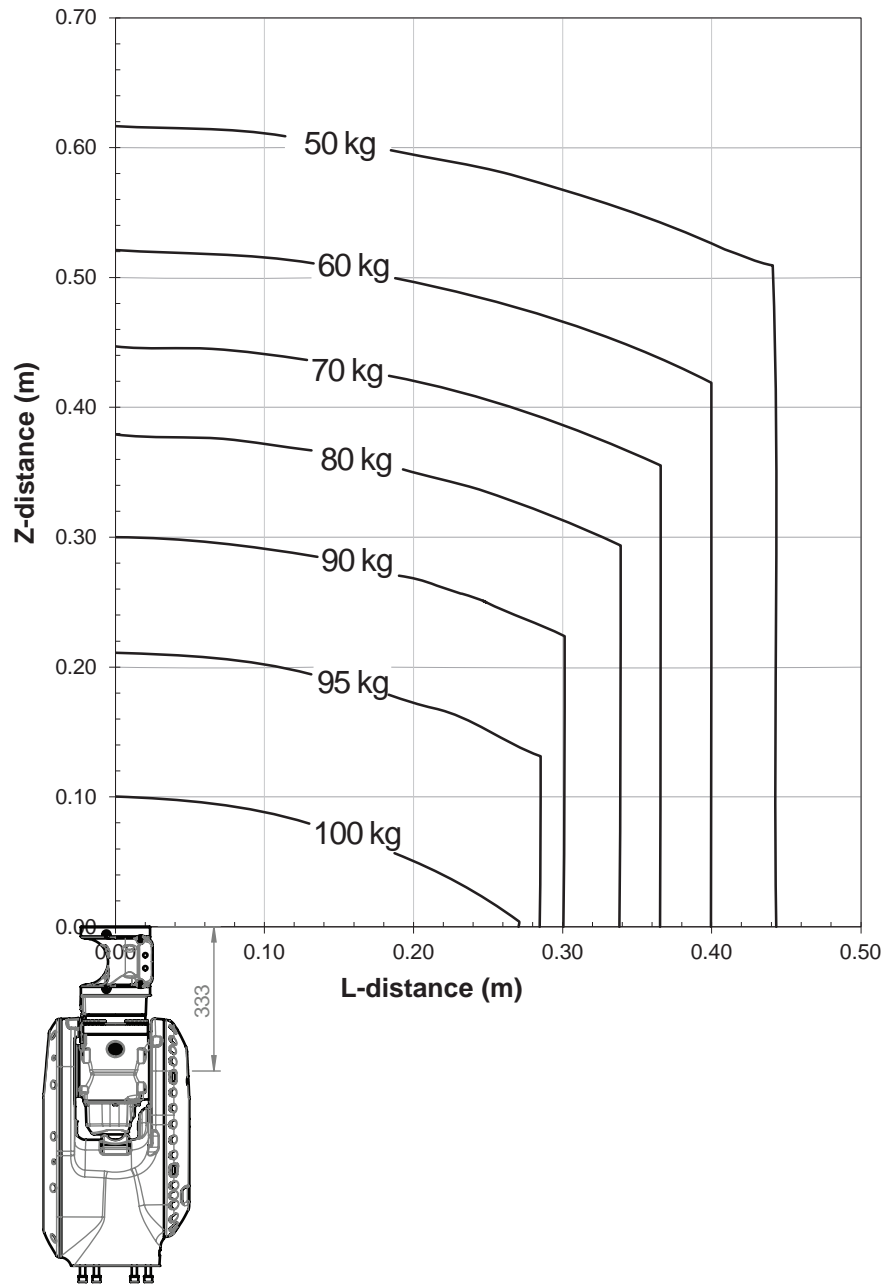

xx2100001498

Continues on next page

## 2 Technical data for IRB 5710

### 2.8.2 Diagrams

Continued

#### Diagrams of IRB 5710-90/2.3 LID ("Vertical Wrist" ( $\pm 10^\circ$ ))

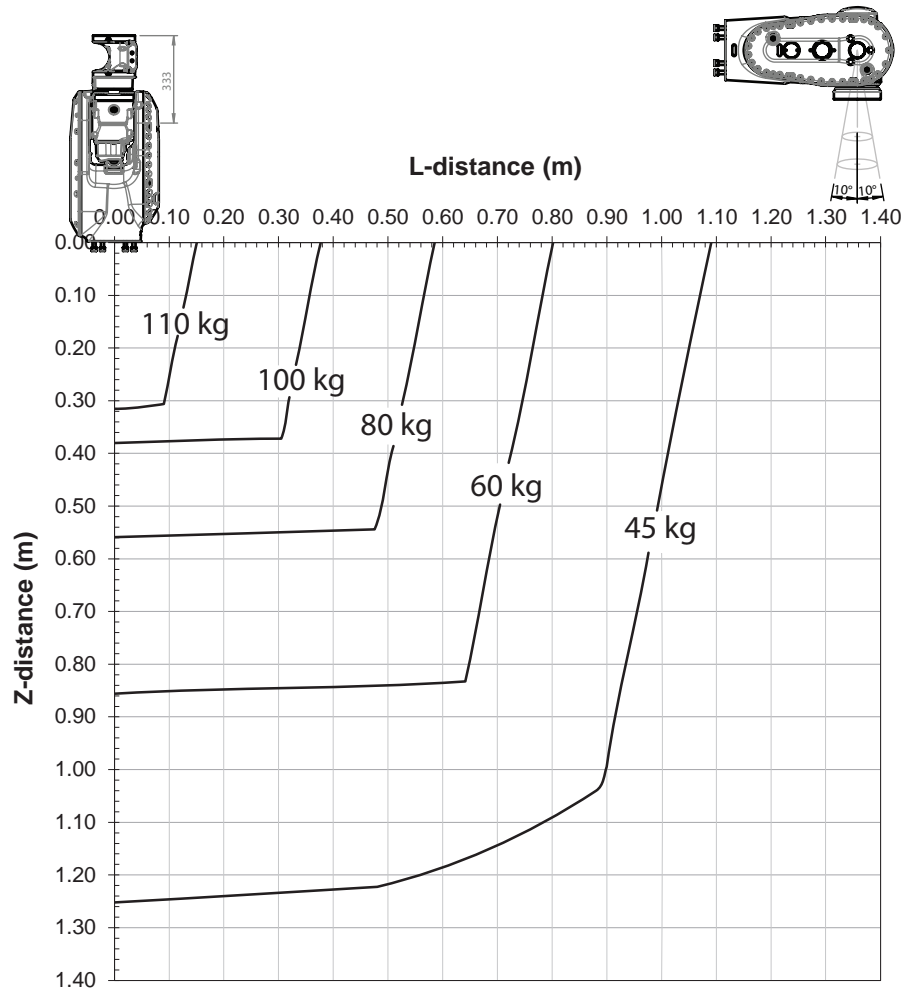

xx2100001499

For wrist down ( $0^\circ$  deviation from the vertical line).

	Description
Max load	118 kg
Z <sub>max</sub>	0.271 m
L <sub>max</sub>	0.054 m

Continues on next page

Diagrams of IRB 5710-70/2.7 LID

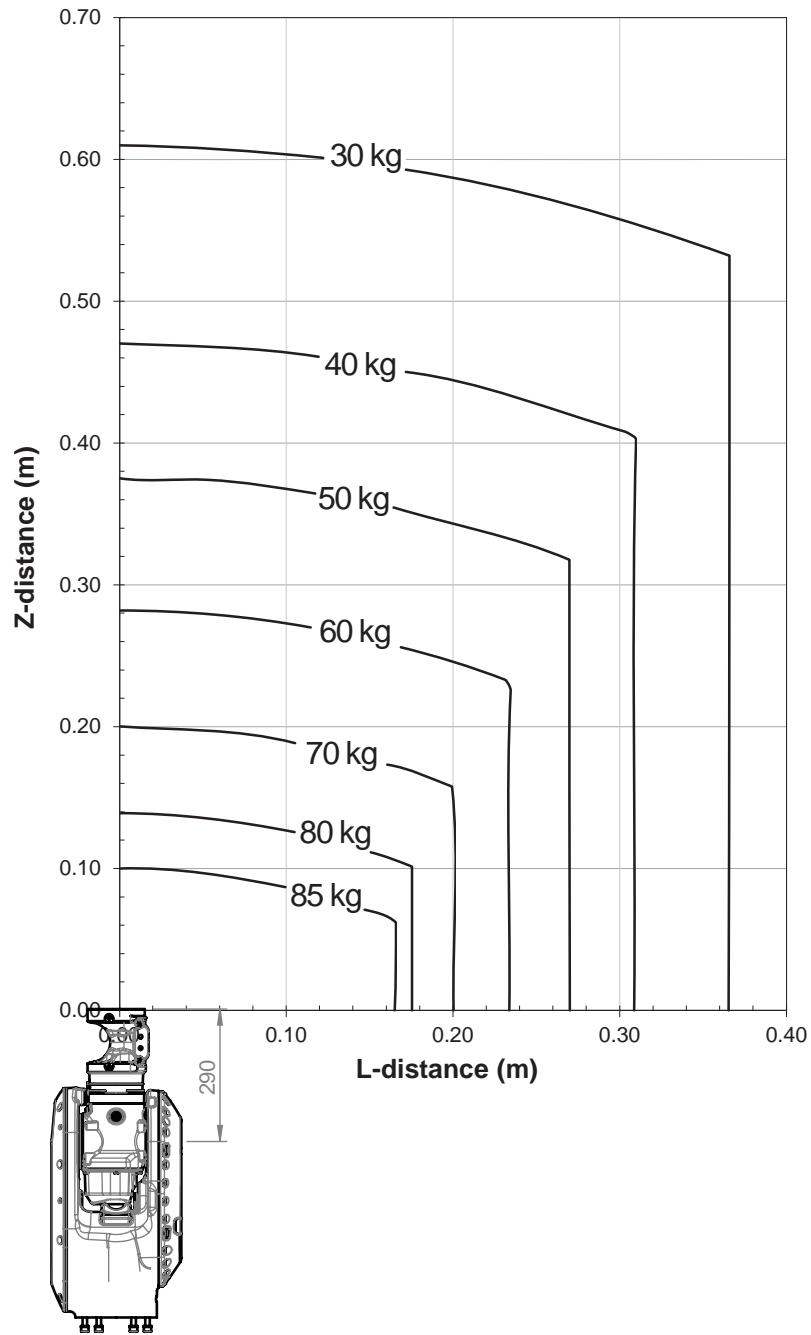

xx2100001502

Continues on next page

## 2 Technical data for IRB 5710

### 2.8.2 Diagrams

Continued

#### Diagrams of IRB 5710-70/2.7 LID ("Vertical Wrist" ( $\pm 10^\circ$ ))

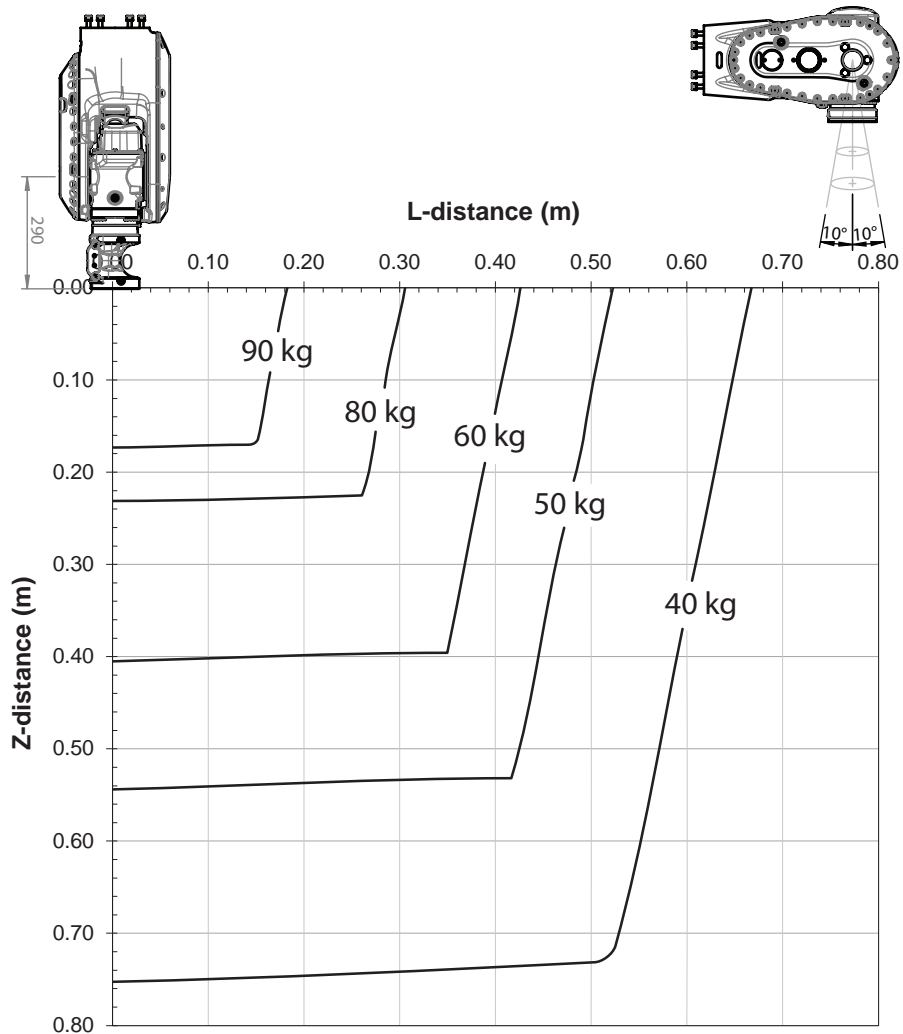

xx2100001503

For wrist down ( $0^\circ$  deviation from the vertical line).

	Description
Max load	97 kg
Z <sub>max</sub>	0.14 m
L <sub>max</sub>	0.038 m

2.8.3 Maximum load and moment of inertia for full and limited axis 5 (center line down) movement

2.8.3 Maximum load and moment of inertia for full and limited axis 5 (center line down) movement



Note

Total load given as: mass in kg, center of gravity (Z and L) in meters and moment of inertia ( $J_{ox}$ ,  $J_{oy}$ ,  $J_{oz}$ ) in  $\text{kgm}^2$ .  $L = \text{sqr}(X^2 + Y^2)$ , see the following figure.

Full movement of axis 5 ( $\pm 130^\circ$ )

Robot variant	Maximum load and moment of inertia	
	Axis 5	Axis 6
IRB 5710-110/2.3	$J_{a5} = \text{Load} \times (Z + 0.18)^2 + \max(J_{0x}, J_{0y}) \leq 195 \text{ kgm}^2$	$J_{a6} = \text{Load} \times L^2 + J_{0z} \leq 145 \text{ kgm}^2$
IRB 5710-90/2.7	$J_{a5} = \text{Load} \times (Z + 0.18)^2 + \max(J_{0x}, J_{0y}) \leq 195 \text{ kgm}^2$	$J_{a6} = \text{Load} \times L^2 + J_{0z} \leq 145 \text{ kgm}^2$
IRB 5710-90/2.3 LID	$J_{a5} = \text{Load} \times (Z + 0.346)^2 + \max(J_{0x}, J_{0y}) \leq 195 \text{ kgm}^2$	$J_{a6} = \text{Load} \times L^2 + J_{0z} \leq 145 \text{ kgm}^2$
IRB 5710-70/2.7 LID	$J_{a5} = \text{Load} \times (Z + 0.346)^2 + \max(J_{0x}, J_{0y}) \leq 195 \text{ kgm}^2$	$J_{a6} = \text{Load} \times L^2 + J_{0z} \leq 145 \text{ kgm}^2$

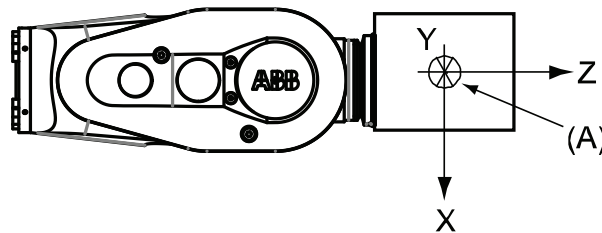

xx1400002028

	Description
A	Center of gravity
	Description
$J_{ox}, J_{oy}, J_{oz}$	Max. moment of inertia around the X, Y and Z axes at center of gravity.

Continues on next page

## 2 Technical data for IRB 5710

### 2.8.3 Maximum load and moment of inertia for full and limited axis 5 (center line down) movement Continued

#### Limited axis 5, center line down

Robot variant	Maximum load and moment of inertia	
	Axis 5	Axis 6
IRB 5710-110/2.3	$J_{a5} = \text{Load} \times (Z + 0.18)^2 + \max(J_{0x}, J_{0y}) \leq 215 \text{ kgm}^2$	$J_{a6} = \text{Load} \times L^2 + J_{0z} \leq 195 \text{ kgm}^2$
IRB 5710-90/2.7	$J_{a5} = \text{Load} \times (Z + 0.18)^2 + \max(J_{0x}, J_{0y}) \leq 215 \text{ kgm}^2$	$J_{a6} = \text{Load} \times L^2 + J_{0z} \leq 195 \text{ kgm}^2$
IRB 5710-90/2.3 LID	$J_{a5} = \text{Load} \times (Z + 0.346)^2 + \max(J_{0x}, J_{0y}) \leq 215 \text{ kgm}^2$	$J_{a6} = \text{Load} \times L^2 + J_{0z} \leq 195 \text{ kgm}^2$
IRB 5710-70/2.7 LID	$J_{a5} = \text{Load} \times (Z + 0.346)^2 + \max(J_{0x}, J_{0y}) \leq 215 \text{ kgm}^2$	$J_{a6} = \text{Load} \times L^2 + J_{0z} \leq 195 \text{ kgm}^2$

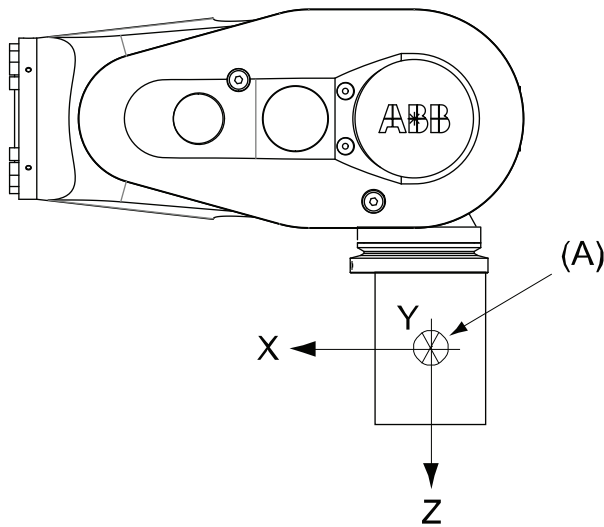

xx1400002029

	Description
A	Center of gravity
	Description
$J_{0x}, J_{0y}, J_{0z}$	Max. moment of inertia around the X, Y and Z axes at center of gravity.

## 2.8.4 Wrist torque



### Note

The wrist torque values are for reference only, and should not be used for calculating permitted load offset (position of center of gravity) within the load diagram, since those also are limited by main axes torques as well as dynamic loads. Furthermore, arm loads will influence the permitted load diagram. To find the absolute limits of the load diagram, use the RobotStudio add-in RobotLoad.

### Permissible torque

The table below shows the maximum permissible torque due to payload.

Robot variant	Maximum wrist torque axis 4 and 5	Maximum wrist torque axis 6	Load at which the maximum torques are valid
IRB 5710-110/2.3	989 Nm	460 Nm	180 kg
IRB 5710-90/2.7	989 Nm	460 Nm	180 kg
IRB 5710-90/2.3 LID	1,120 Nm	426 Nm	155 kg
IRB 5710-70/2.7 LID	1,120 Nm	426 Nm	155 kg

## 2 Technical data for IRB 5710

---

### 2.8.5 Maximum TCP acceleration

### 2.8.5 Maximum TCP acceleration

---

#### General

Higher values can be reached with lower loads than the nominal because of our dynamical motion control QuickMove2. For specific values in the unique customer cycle, or for robots not listed in the table below, we recommend to use RobotStudio.

---

#### Maximum Cartesian design acceleration for nominal loads

Robot variant	E-stop Max acceleration at nominal load COG [m/s <sup>2</sup> ]	Controlled Motion Max acceleration at nominal load COG [m/s <sup>2</sup> ]
IRB 5710-110/2.3	53	36
IRB 5710-90/2.7	60	38
IRB 5710-90/2.3 LID	65	37
IRB 5710-70/2.7 LID	65	38



#### Note

Acceleration levels for emergency stop and controlled motion includes acceleration due to gravitational forces. Nominal load is defined with nominal mass and cog with max offset in Z and L (see the load diagram).



## 2.9 Performance according to ISO 9283

### General

At rated maximum load, maximum offset and 1.6 m/s velocity on the inclined ISO test plane, with all six axes in motion. Values in the table below are the result of measurements using the robots Accuracy mode. The result may differ depending on where in the working range the robot is positioning, velocity, arm configuration, from which direction the position is approached and the load direction of the arm system. Backlashes in gearboxes also affect the result.

The figures for AP, RP, AT and RT are measured according to figure below.

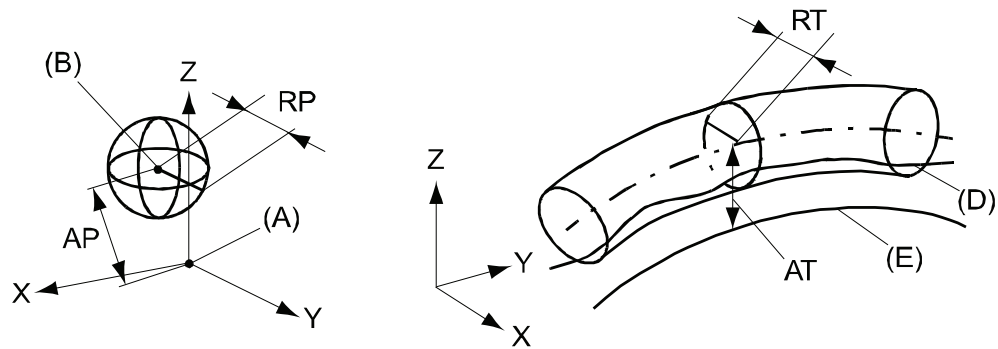

xx080000424

Pos	Description	Pos	Description
A	Programmed position	E	Programmed path
B	Mean position at program execution	D	Actual path at program execution
AP	Mean distance from programmed position	AT	Max deviation from E to average path
RP	Tolerance of position B at repeated positioning	RT	Tolerance of the path at repeated program execution

### Pose data and path accuracy

Data <sup>i</sup>	IRB 5710-110/2.3	IRB 5710-90/2.7
Pose accuracy, AP (mm) <sup>ii</sup>	0.03	0.01
Pose repeatability, RP (mm)	0.04	0.03
Pose stabilization time, PSt (s) within 0.5 mm of the position	0.1	0.1
Path accuracy, AT (mm)	1.1	0.9
Path repeatability, RT (mm)	0.08	0.09

<sup>i</sup> LID manipulator variants are considered to have the same data as specified variants with the same reach.

<sup>ii</sup> AP according to the ISO test above, is the difference between the taught position (position manually modified in the cell) and the average position obtained during program execution.

## 2 Technical data for IRB 5710

---

### 2.10 Velocity

### 2.10 Velocity

---

#### Maximum axis speed

Robot variant	Axis 1	Axis 2	Axis 3	Axis 4	Axis 5	Axis 6
IRB 5710-110/2.3	110°/s	110°/s	110°/s	200°/s	150°/s	210°/s
IRB 5710-90/2.7	110°/s	100°/s	90°/s	200°/s	150°/s	210°/s
IRB 5710-90/2.3 LID	110°/s	110°/s	110°/s	200°/s	150°/s	210°/s
IRB 5710-70/2.7 LID	110°/s	100°/s	90°/s	200°/s	150°/s	210°/s

There is a supervision function to prevent overheating in applications with intensive and frequent movements (high duty cycle).

## 2.11 Robot stopping distances and times

### 2.11.1 Robot stopping distances according to ISO 10218-1

#### About the data for robot stopping distances and times

All measurements and calculations of stopping distances and times are done according to ISO 10218-1, with single axis motion on axes 1, 2, and 3. If more than one axis is used for the movement, then the stopping distance and time can be longer. Normal delays of the hardware and software are taken into account. See more about the delays and their impact on the results, [Reading the data on page 85](#).

The stopping distances and times are presented using the tool data and extension zones presented for the respected robot variant. These variables are 100%, 66%, and 33% of the maximum values for the robot.

The stop categories 0 and 1 are according to IEC 60204-1.



#### Note

The category 0 stop is not necessarily the worst case (depending on load, speed, application, wear, etc.).



#### Note

The stop category 1 is a controlled stop and will therefore have less deviation from the programmed path compared with a stop category 0.

#### Loads

The tool data that is used is presented for the respective robot variant.

The used loads represent the rated load. No arm load is used. See the [Load diagrams on page 67](#).

*Continues on next page*

## 2 Technical data for IRB 5710

### 2.11.1 Robot stopping distances according to ISO 10218-1

Continued

#### Extension zones

The extension zone for the stop category 1 is based on the tool mounting interface (tool flange) with the axis angles according to the following illustrations. The zone data is presented for the respective robot variant.

The extension zone outer limits are defined by the TCP0 position for the stated angles.

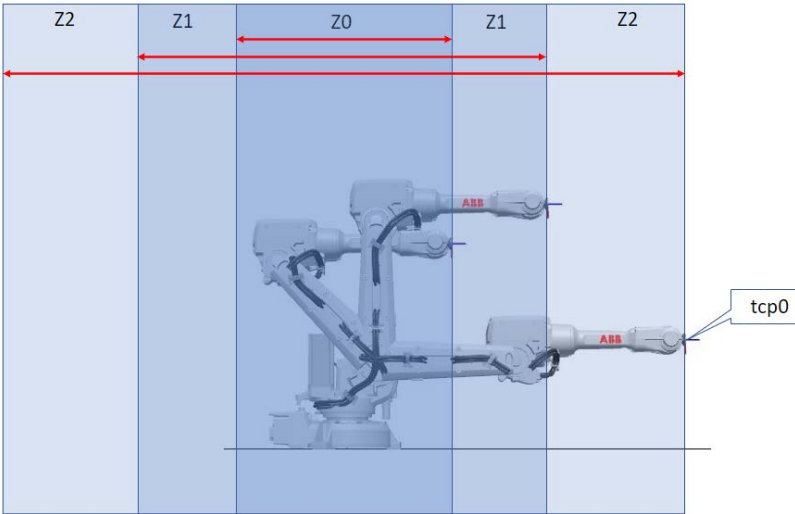
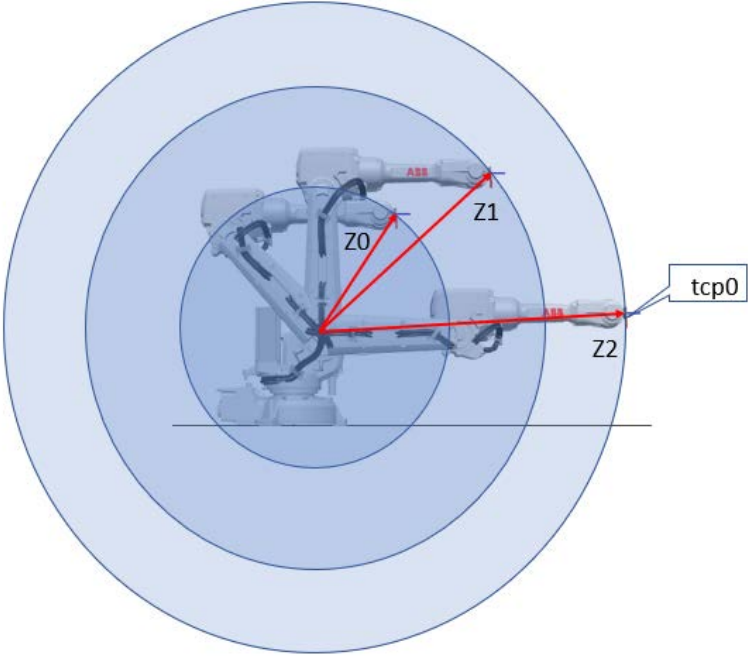
	Illustration
Axis 1	 <p>xx2300000860</p>
Axis 2	 <p>xx2300000861</p>

Continues on next page

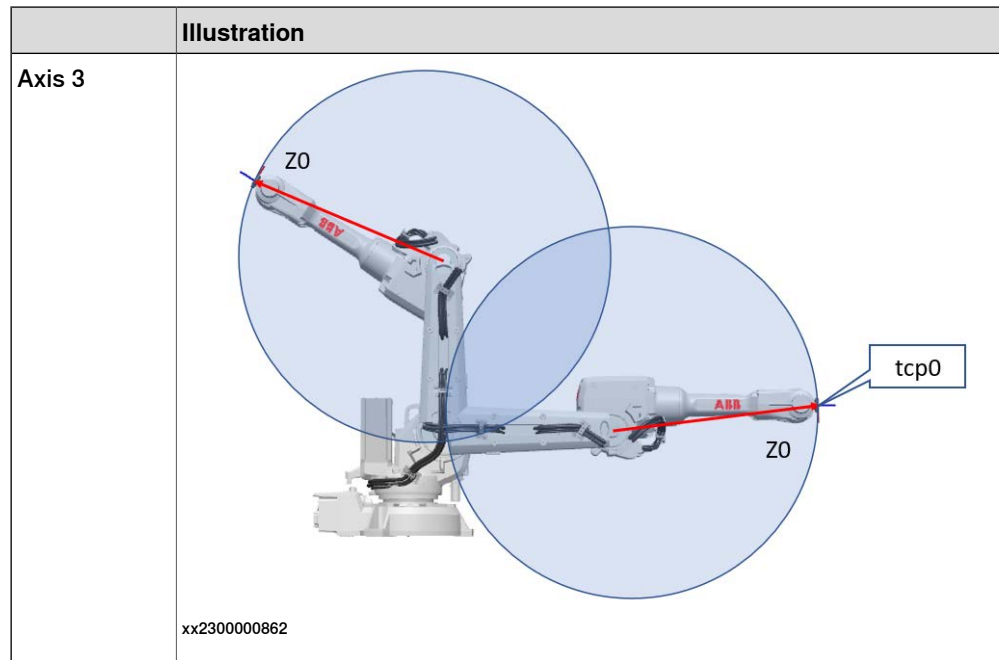

**Speed**

The speed in the simulations is based on TCP0.  
 The TCP0 speed is measured in meters per second when the stop is triggered.

**Stopping distances**

The stopping distance is measured in degrees.

**Stopping times**

The stopping time is measured in seconds.

**Limitations**

The stopping distance can vary depending on additional loads on the robot.  
 The stopping distance for category 0 stops can vary depending on the individual brakes and the joint friction.

**Reading the data**

The data for stop category 0 is presented in tables, with distance and time for each axis.  
 The data for stop category 1 is presented as graphs with curves representing the different loads.  
 There is a short delay in the stop, which means that if the axis is accelerating when the stop is initiated (C), it will continue to accelerate during this delay time. This

*Continues on next page*

## 2 Technical data for IRB 5710

### 2.11.1 Robot stopping distances according to ISO 10218-1

Continued

can result in graphs where a higher load (A) gives shorter stopping distance than a smaller load (B).

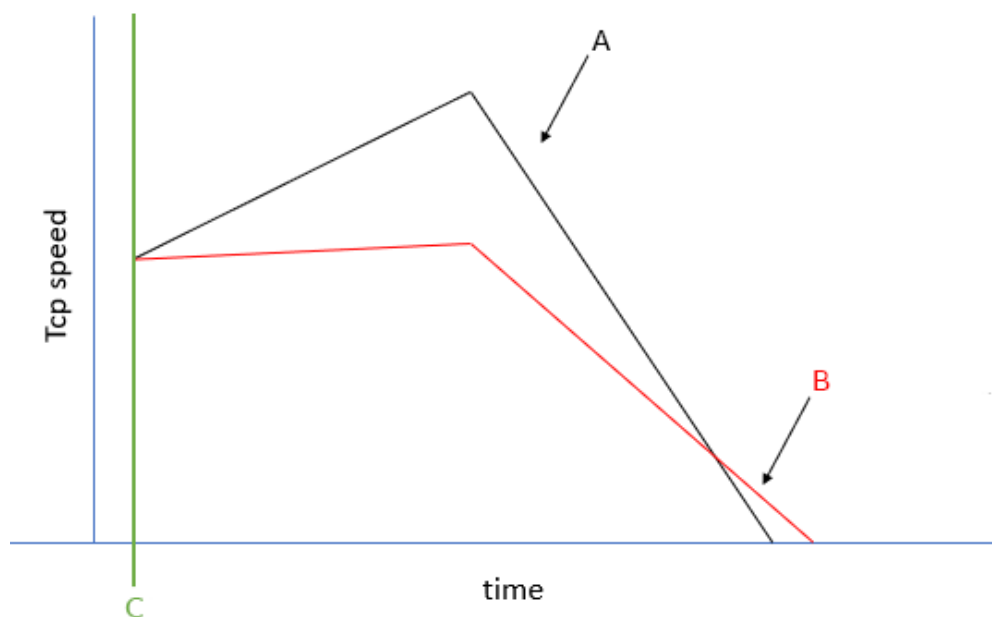

xx2300001041

The tcp speed is the actual speed when the stop is initiated, which is not necessarily the programmed speed.

## 2.11.2 Measuring stopping distance and time

### Preparations before measuring

For measurement and calculation of overall system stopping performance, see ISO 13855:2010.

The measurement shall be done for the selected stop category. The emergency stop button on the robot controller is configured for stop category 0 on delivery. A risk assessment can conclude the need for another stop category. The stop category can be changed through the system parameter *Function* (topic *Controller*, type *Safety Run Chain*). In case of deviations of the default configuration of stop category 0, then this is detailed in the product specification for the respective manipulator.



#### CAUTION

The measurement and calculation of overall stopping performance for a robot must be tested with its correct load, speed, and tools, in its actual environment, before the robot is taken into production.

All load and tool data must be correctly defined (weight, CoG, moment of inertia). The load identification service routine can be used to identify the data.



#### CAUTION

Follow the safety instructions in the respective product manual for the robot.

### Measuring with TuneMaster

The software TuneMaster can be used to measure stopping distances and times for ABB robots. The TuneMaster software contains documentation on how to use it.

- 1 Download TuneMaster from [www.abb.com/robotics](http://www.abb.com/robotics), section **RobotStudio - Downloads - RobotWare Tools and Utilities**.
- 2 Install TuneMaster on a computer. Start the TuneMaster app and select **Log Signals**.
- 3 Connect to the robot controller.
- 4 Define the I/O stop signal to use for measurement, for example, ES1 for emergency stop.
- 5 Define the signal number to use for measurement, 1298 for axis position. The value is given in radians.
- 6 Start the logging in TuneMaster.
- 7 Start the test program on the controller.



#### Tip

Use the tool and zone definitions for the respective variant in this document to get results that are comparable with this document.

*Continues on next page*

## 2 Technical data for IRB 5710

### 2.11.2 Measuring stopping distance and time

*Continued*

- 8 When the axis has reached maximum speed, press the emergency stop button.
- 9 In TuneMaster, measure the stopping distance and time.
- 10 Repeat for all installed emergency stop buttons until the identified hazards due to stopping distance and time for axes have been verified.

Example from TuneMaster

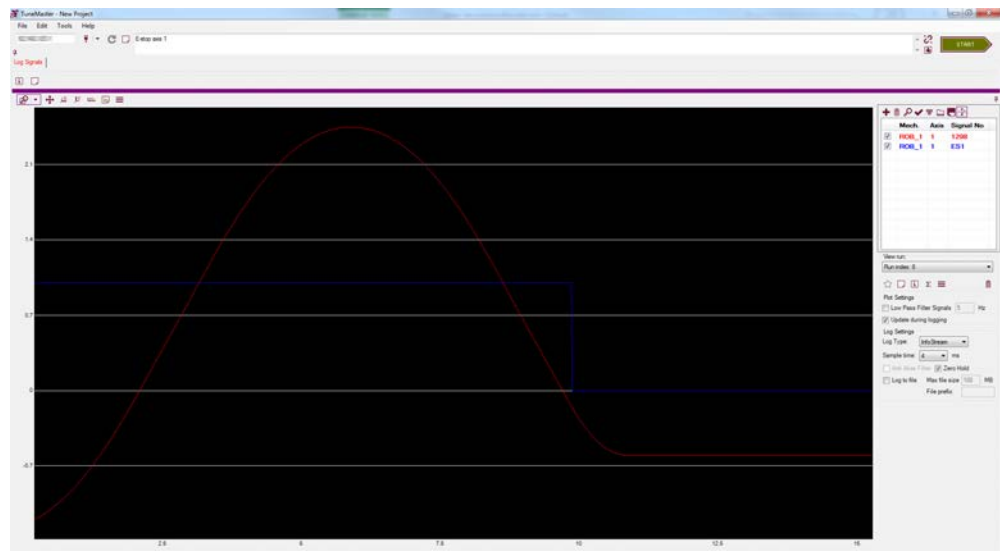

xx160000386



## 2.11.3 IRB 5710-110/2.3

## Used tooldata

```

PERS tooldata P100:= [ TRUE, [[0, 0, 0], [1, 0, 0, 0]], [110, [0,
0, 300], [1, 0, 0, 0], 1.7, 1.7, 1.7]];
PERS tooldata P66:= [ TRUE, [[0, 0, 0], [1, 0, 0, 0]], [73, [0, 0,
200], [1, 0, 0, 0], 0.73, 0.73, 0.73]];
PERS tooldata P33:= [ TRUE, [[0, 0, 0], [1, 0, 0, 0]], [37, [0, 0,
100], [1, 0, 0, 0], 0.18, 0.18, 0.18]];

```

## Category 0

The following table describes the stopping distance and time for category 0 stop.

Axis	Distance	Stop time
1	46.7°	0.54 s
2	27.9°	0.35 s
3	28.4°	0.3 s

## Category 1, extension zones

For definitions of the zones, see [Extension zones on page 84](#).

The zone border is the mounting interface location for axis 2 and axis 3.

## Axis 1

Zone border	Axis 2	Axis 3
z0-z1	-42°	42°
z1-z2	6°	-6°

## Axis 2

Zone border	Axis 2	Axis 3
z0-z1	48°	30°
z1-z2	90°	-30°

## Axis 3

Only one zone exists.

*Continues on next page*

## 2 Technical data for IRB 5710

### 2.11.3 IRB 5710-110/2.3

Continued

#### Category 1, Axis 1, Extension zone 0, stopping distance and stopping time

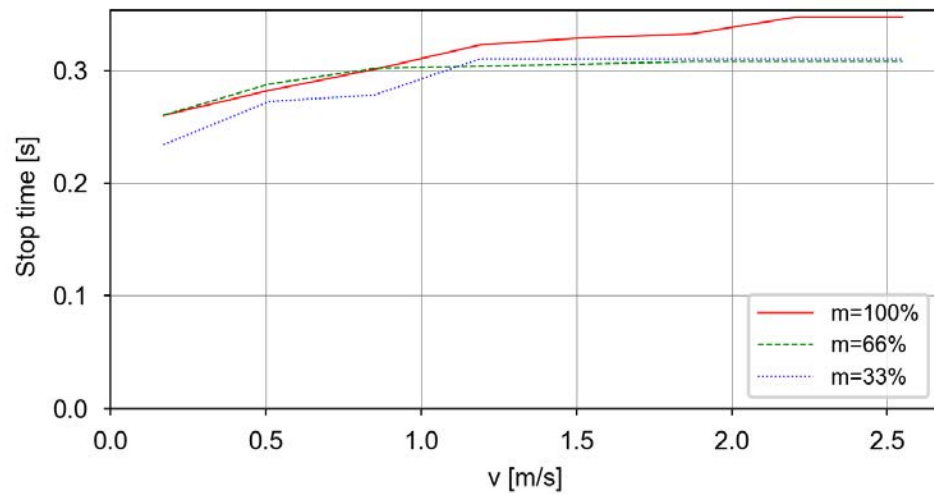
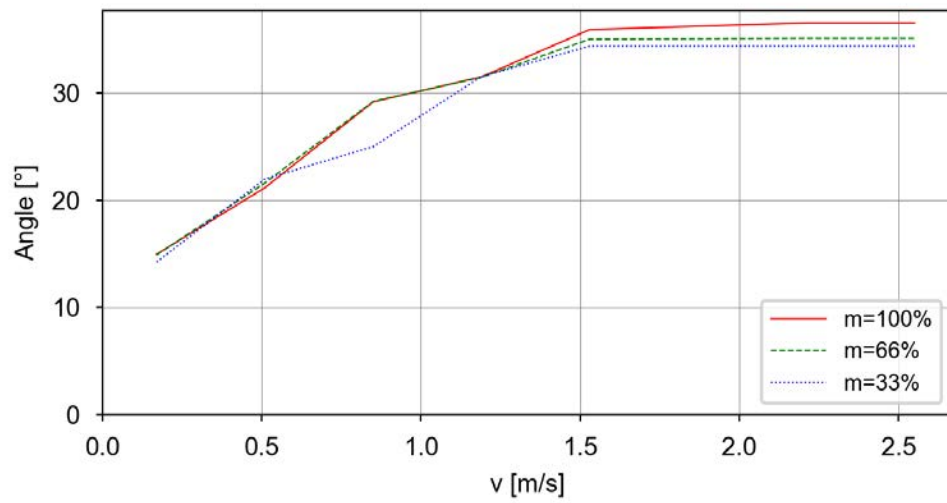

Continues on next page

Category 1, Axis 1, Extension zone 1, stopping distance and stopping time

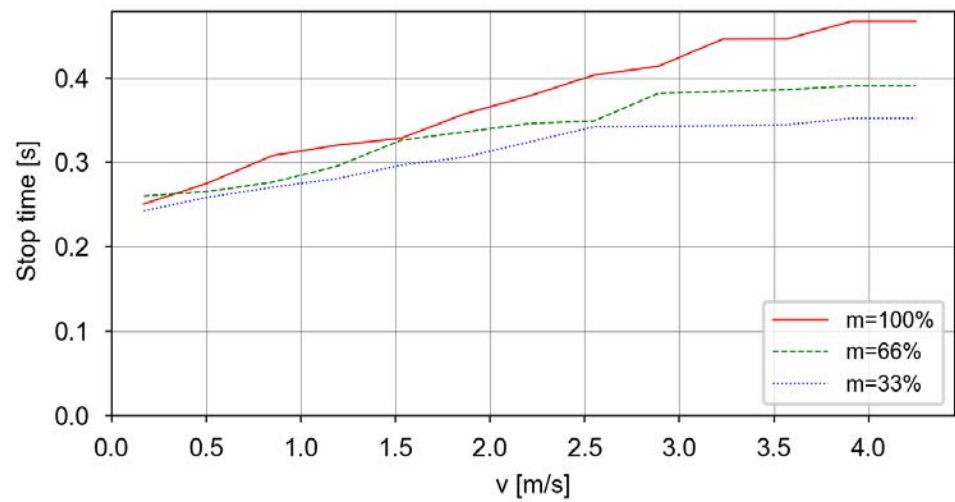
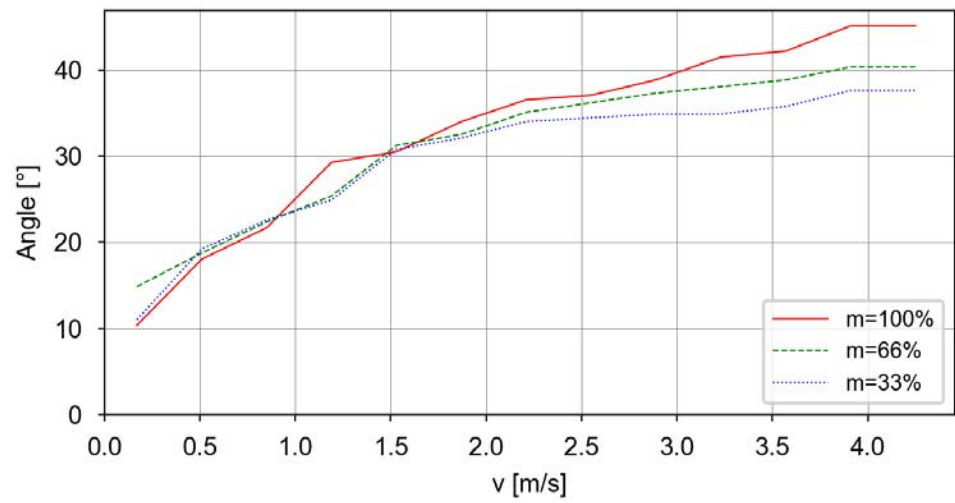

Continues on next page

## 2 Technical data for IRB 5710

### 2.11.3 IRB 5710-110/2.3

Continued

#### Category 1, Axis 1, Extension zone 2, stopping distance and stopping time

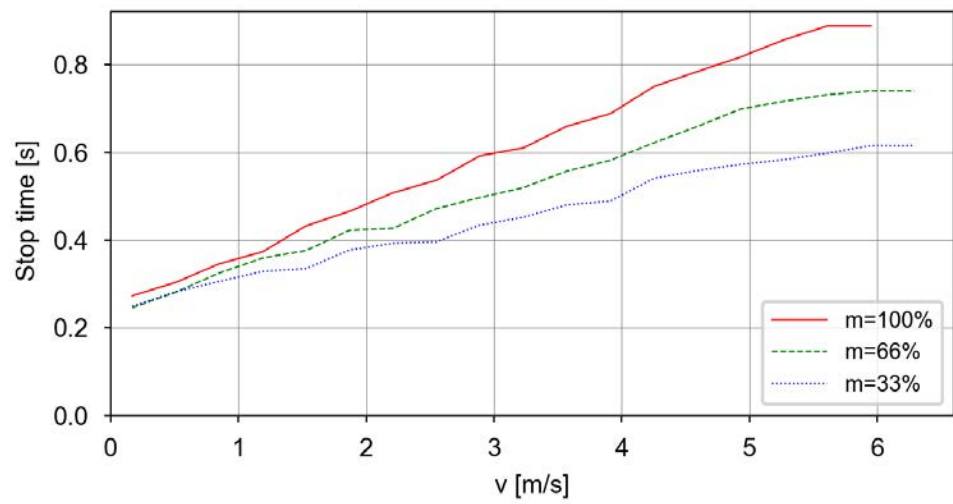
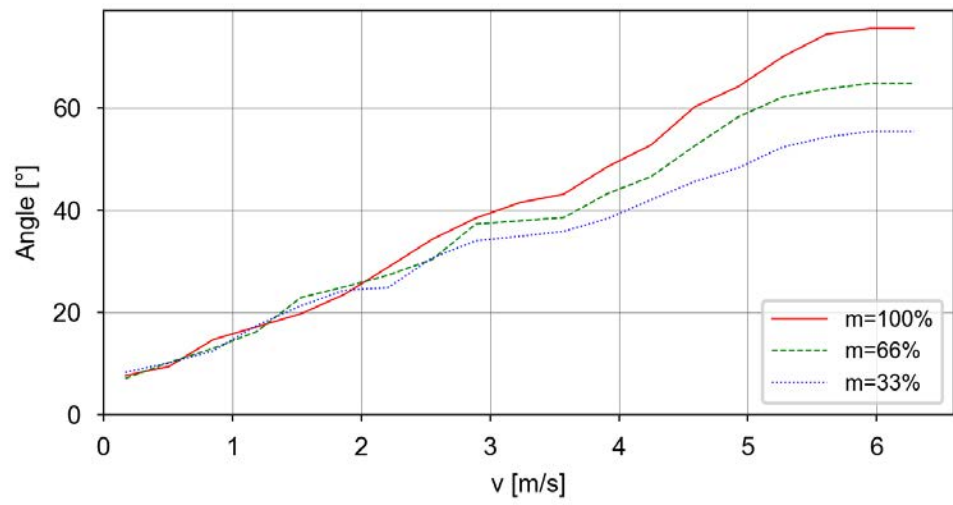

Continues on next page

Category 1, Axis 2, Extension zone 0, stopping distance and stopping time

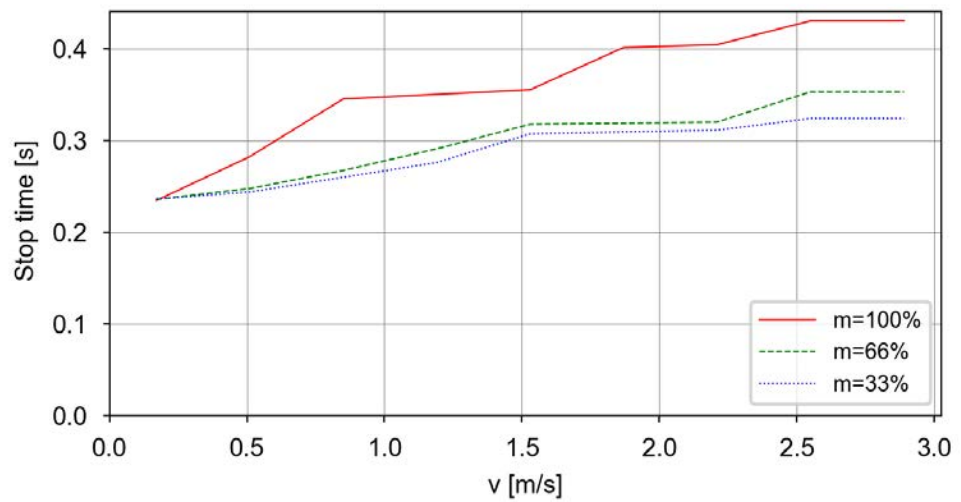
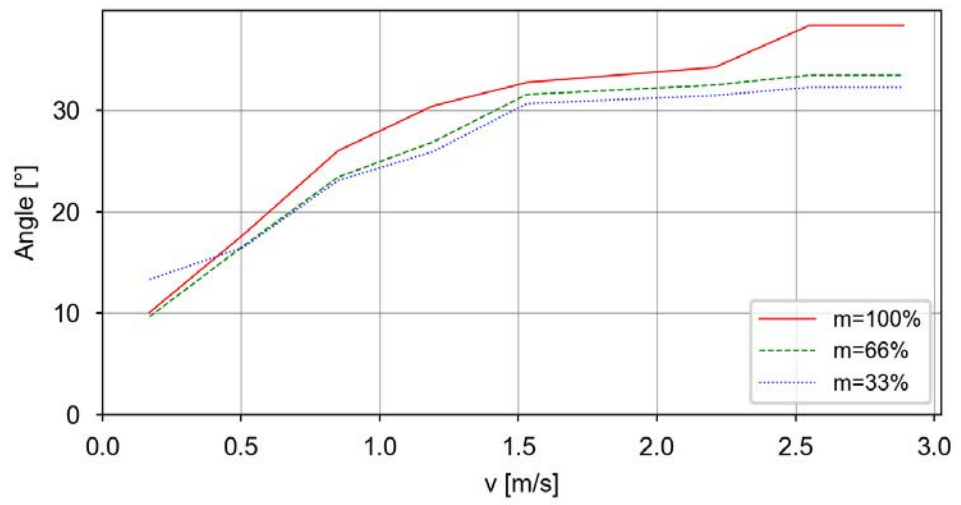

Continues on next page

## 2 Technical data for IRB 5710

### 2.11.3 IRB 5710-110/2.3

Continued

#### Category 1, Axis 2, Extension zone 1, stopping distance and stopping time

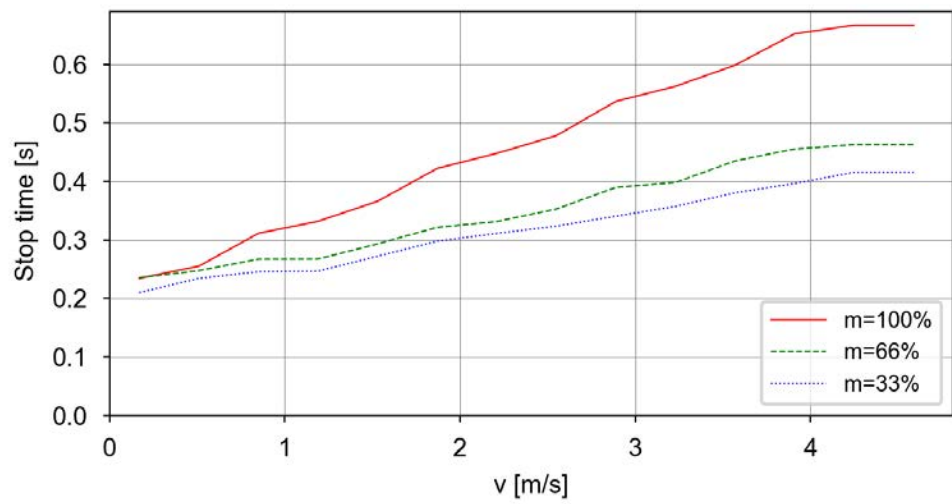
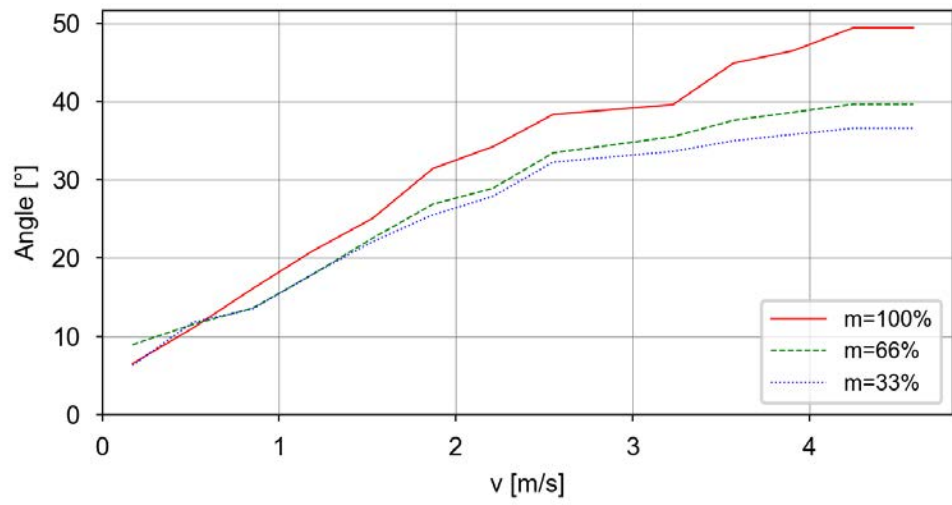

Continues on next page

Category 1, Axis 2, Extension zone 2, stopping distance and stopping time

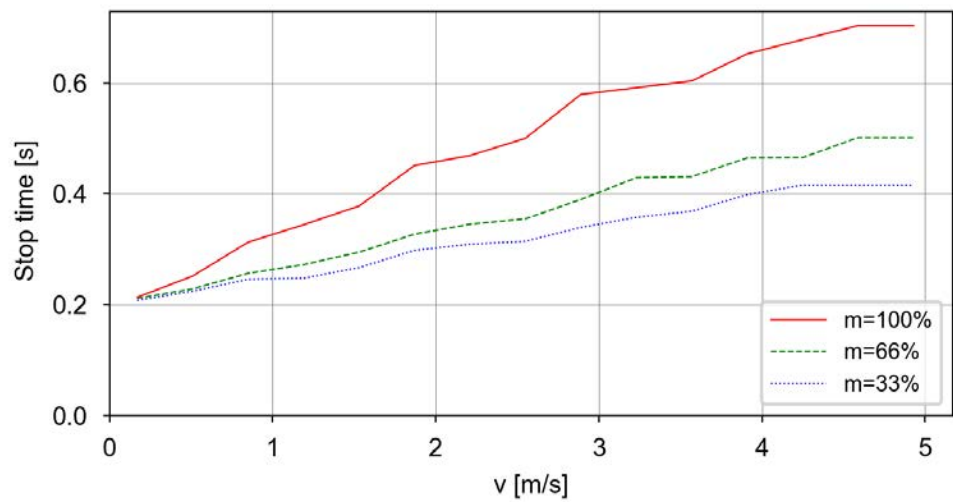
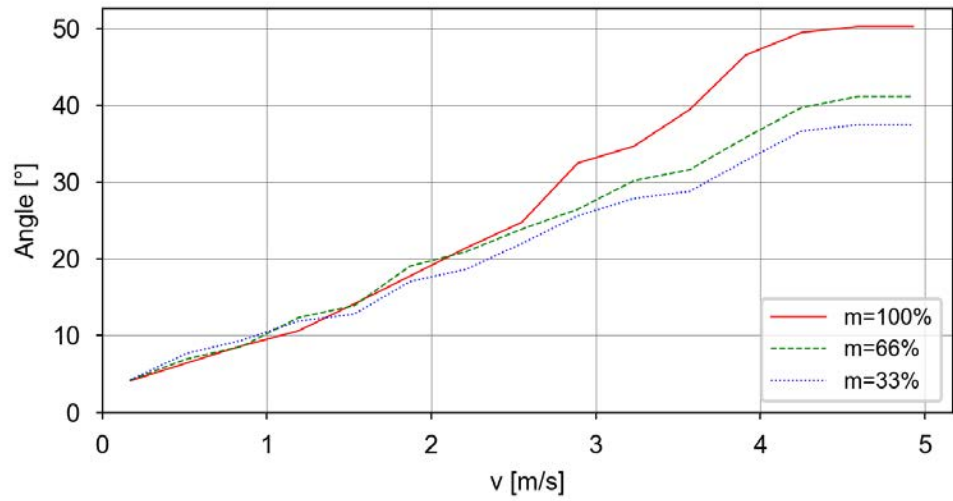

Continues on next page

## 2 Technical data for IRB 5710

### 2.11.3 IRB 5710-110/2.3

Continued

#### Category 1, Axis 3, Extension zone 0, stopping distance and stopping time

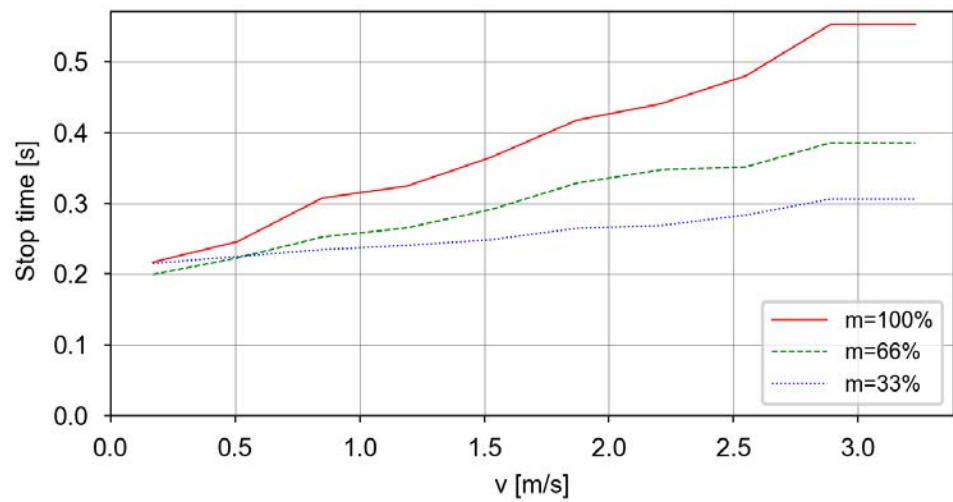
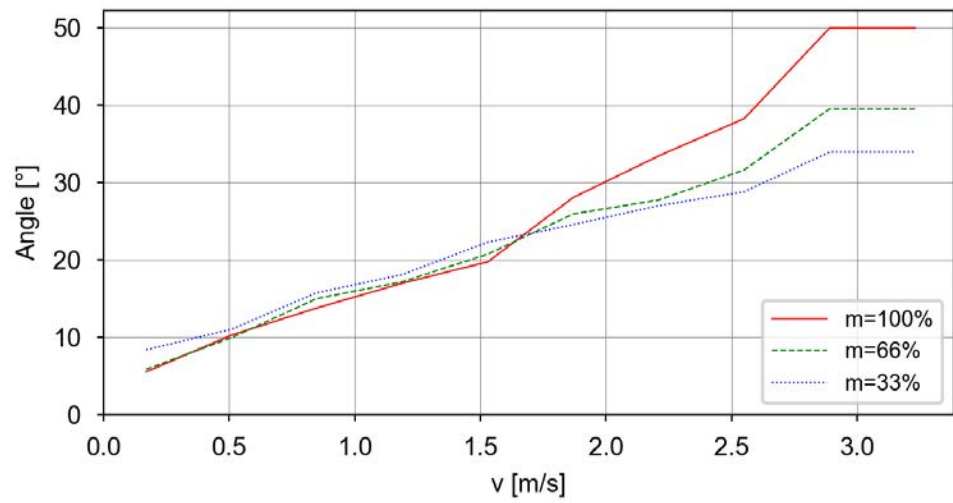



## 2.11.4 IRB 5710-110/2.3 Inv

## Used tooldata

```

PERS tooldata P100:= [ TRUE, [[0, 0, 0], [1, 0, 0, 0]], [110, [0,
0, 300], [1, 0, 0, 0], 1.7, 1.7, 1.7]];
PERS tooldata P66:= [ TRUE, [[0, 0, 0], [1, 0, 0, 0]], [73, [0, 0,
200], [1, 0, 0, 0], 0.73, 0.73, 0.73]];
PERS tooldata P33:= [ TRUE, [[0, 0, 0], [1, 0, 0, 0]], [37, [0, 0,
100], [1, 0, 0, 0], 0.18, 0.18, 0.18]];

```

## Category 0

The following table describes the stopping distance and time for category 0 stop.

Axis	Distance	Stop time
1	46.7°	0.54 s
2	29.2°	0.36 s
3	28.6°	0.31 s

## Category 1, extension zones

For definitions of the zones, see [Extension zones on page 84](#).

The zone border is the mounting interface location for axis 2 and axis 3.

## Axis 1

Zone border	Axis 2	Axis 3
z0-z1	-42°	42°
z1-z2	6°	-6°

## Axis 2

Zone border	Axis 2	Axis 3
z0-z1	48°	30°
z1-z2	90°	-30°

## Axis 3

Only one zone exists.

*Continues on next page*

## 2 Technical data for IRB 5710

### 2.11.4 IRB 5710-110/2.3 Inv

Continued

#### Category 1, Axis 1, Extension zone 0, stopping distance and stopping time

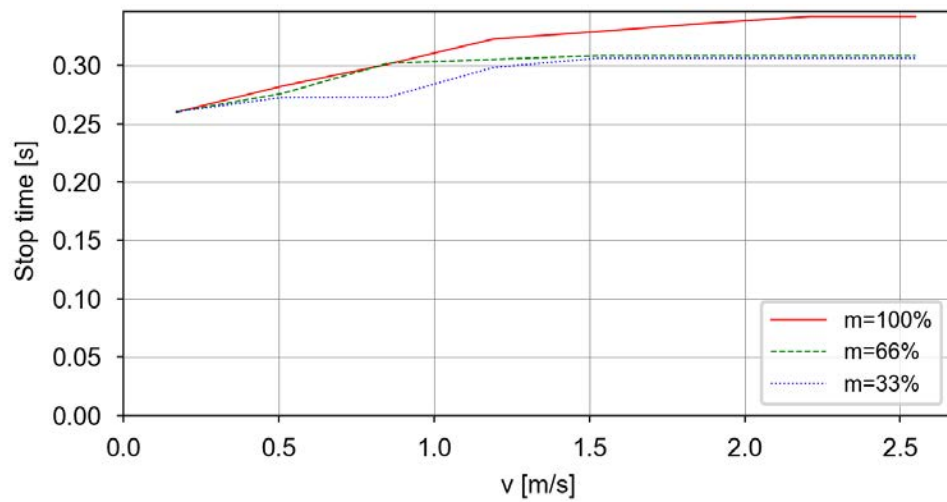
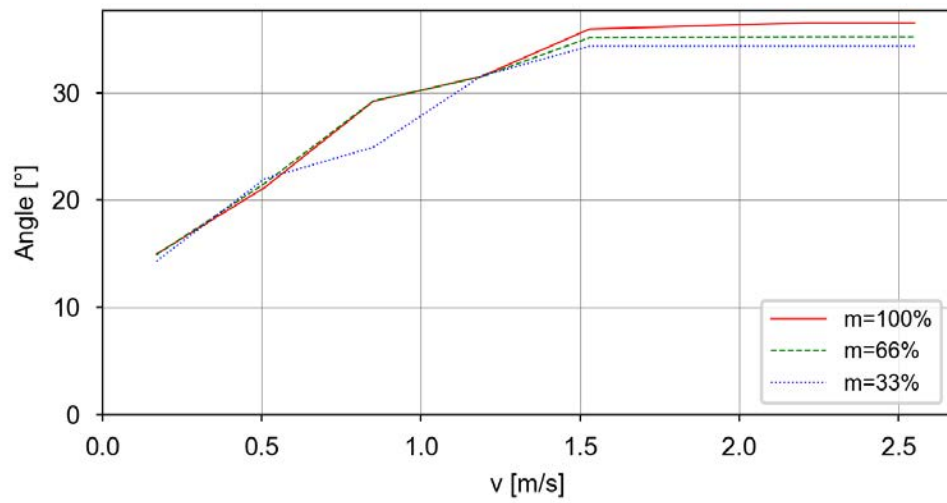

Continues on next page

Category 1, Axis 1, Extension zone 1, stopping distance and stopping time

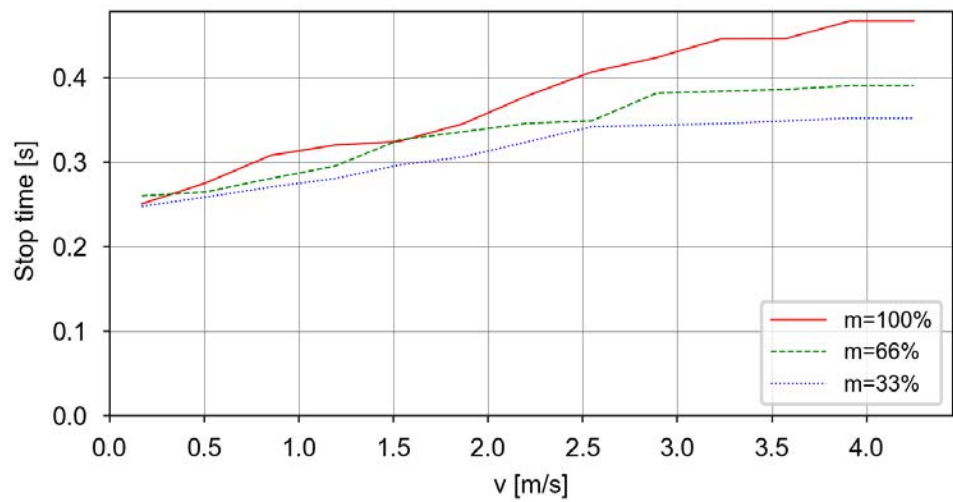
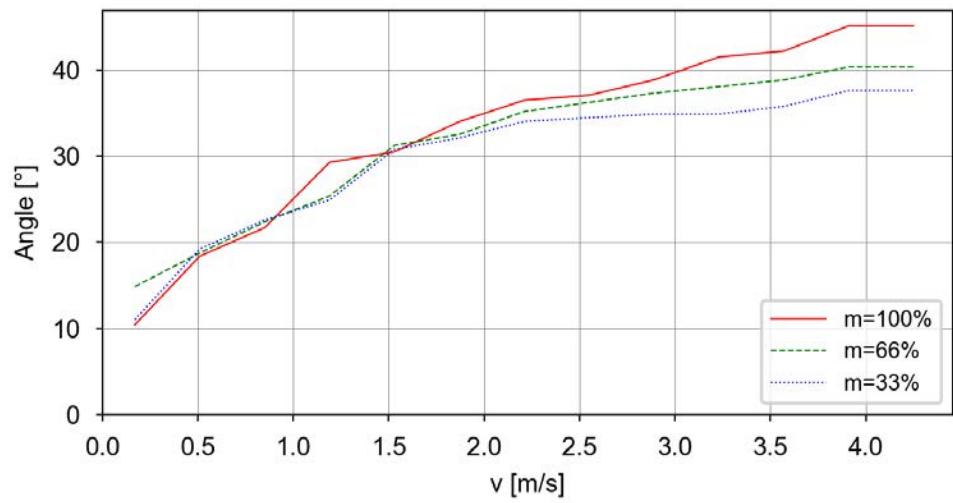

Continues on next page

## 2 Technical data for IRB 5710

### 2.11.4 IRB 5710-110/2.3 Inv

Continued

#### Category 1, Axis 1, Extension zone 2, stopping distance and stopping time

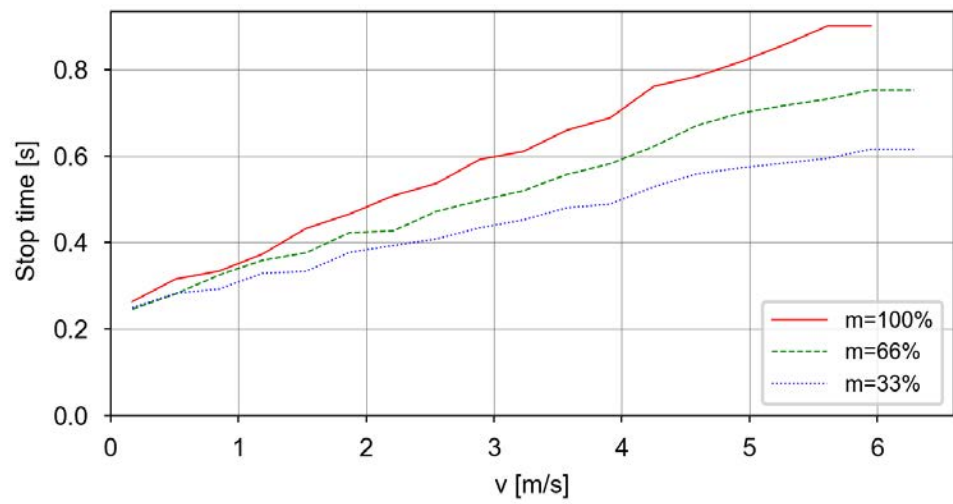
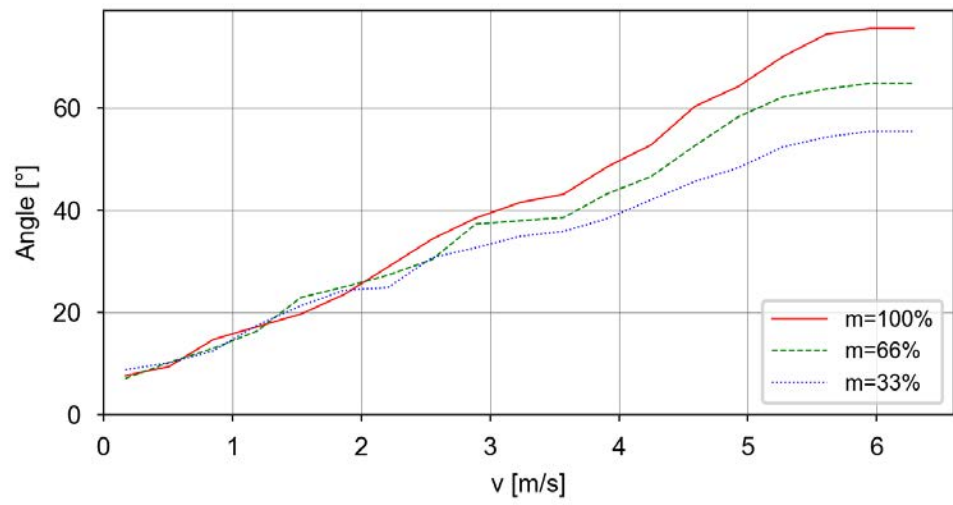

Continues on next page

Category 1, Axis 2, Extension zone 0, stopping distance and stopping time

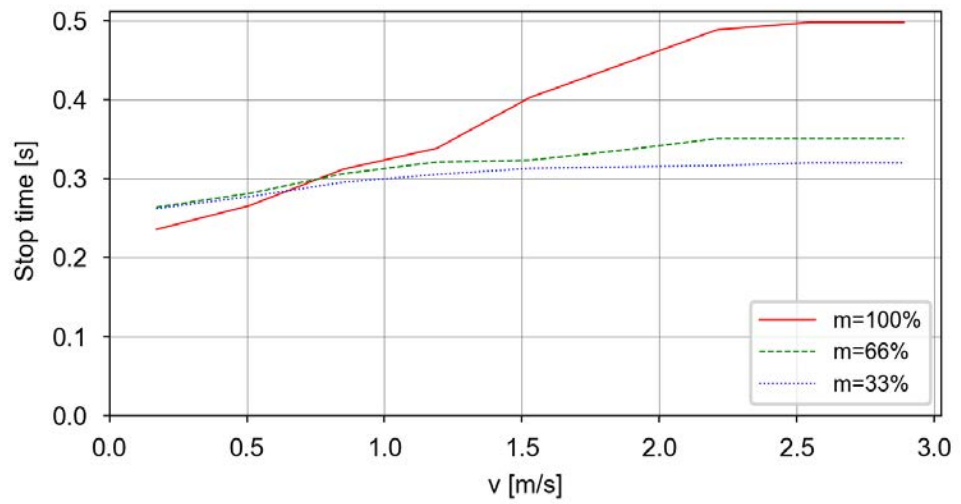
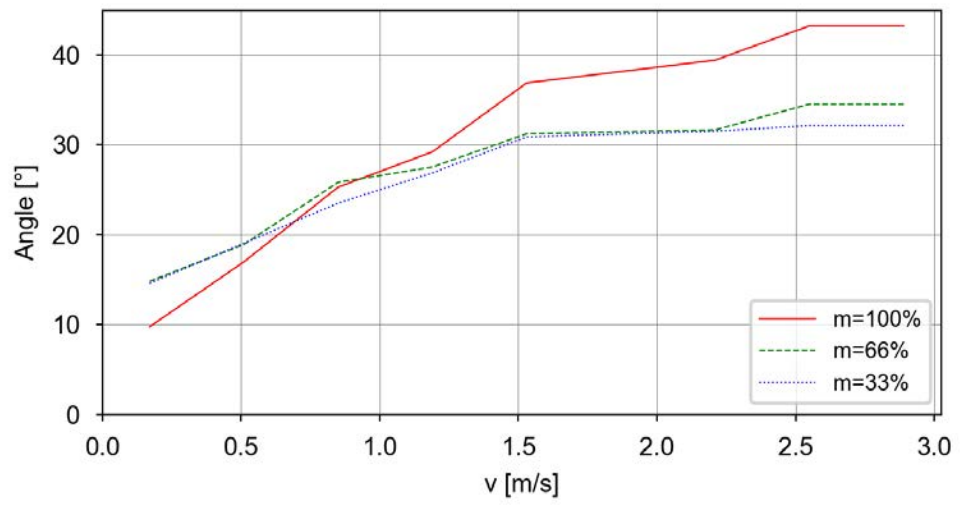

Continues on next page

## 2 Technical data for IRB 5710

### 2.11.4 IRB 5710-110/2.3 Inv

Continued

#### Category 1, Axis 2, Extension zone 1, stopping distance and stopping time

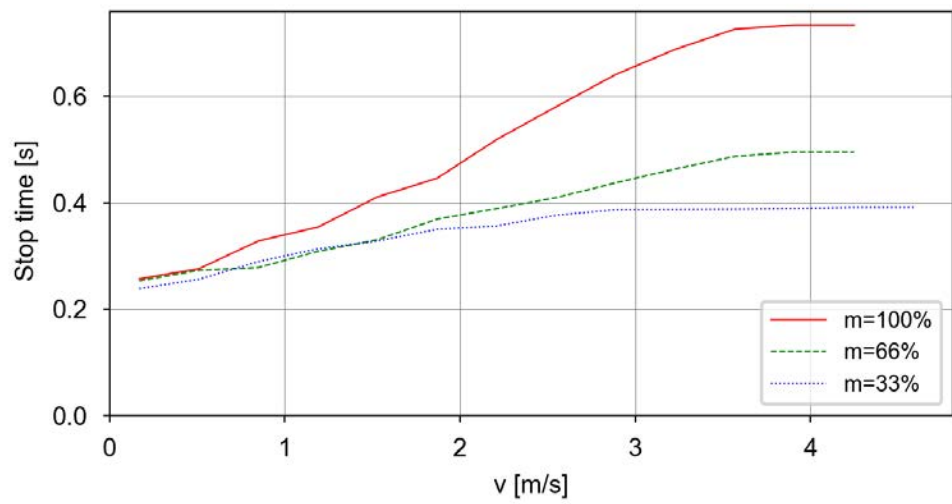
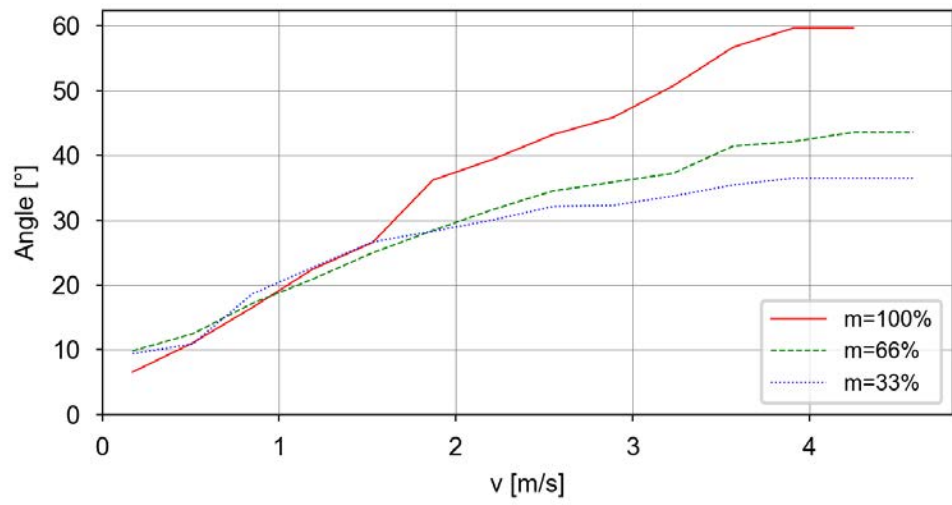

Continues on next page

Category 1, Axis 2, Extension zone 2, stopping distance and stopping time

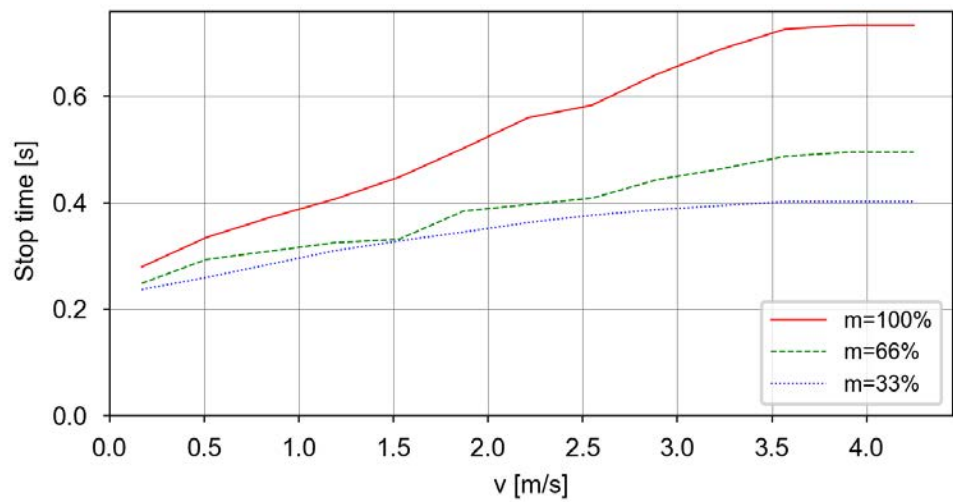
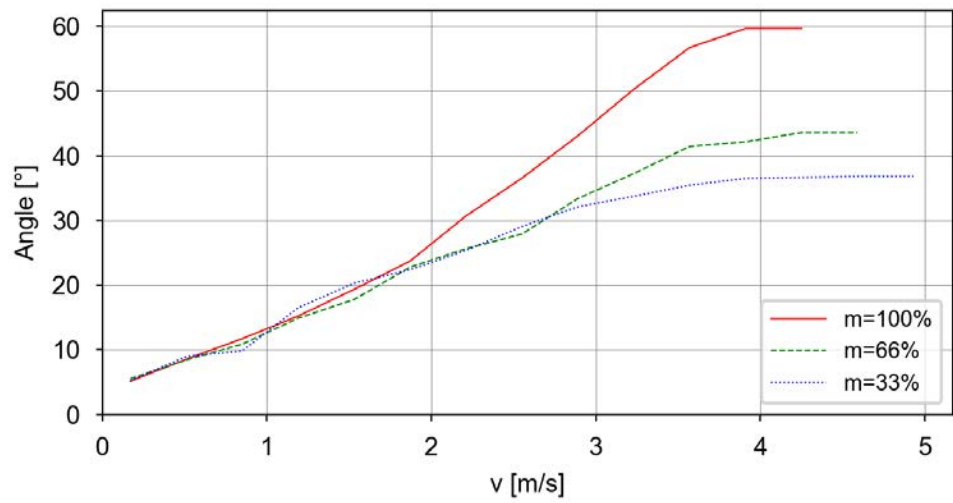

Continues on next page

## 2 Technical data for IRB 5710

### 2.11.4 IRB 5710-110/2.3 Inv

Continued

#### Category 1, Axis 3, Extension zone 0, stopping distance and stopping time

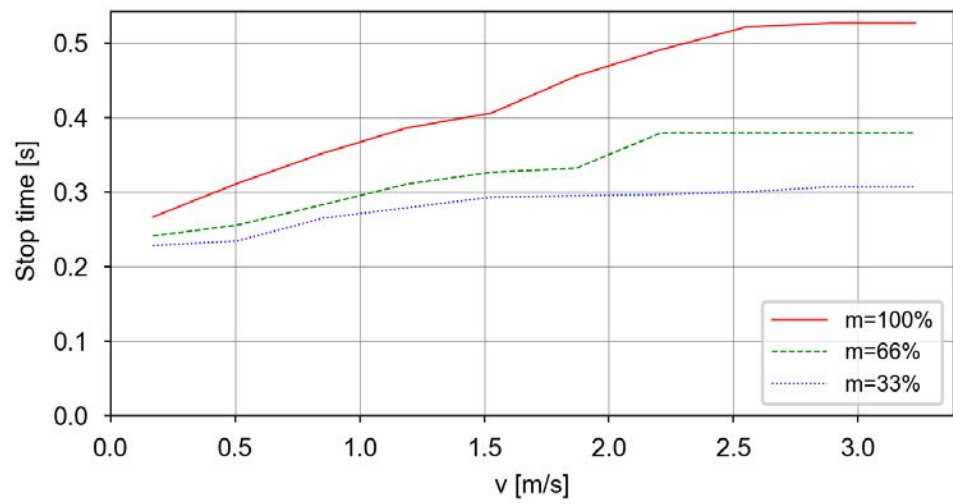
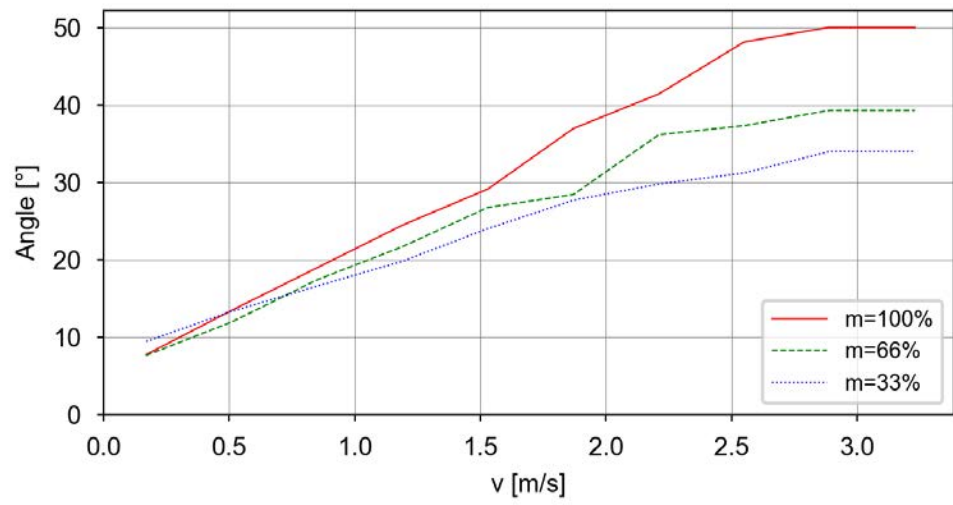



## 2.11.5 IRB 5710-90/2.7

## Used tooldata

```

PERS tooldata P100:= [ TRUE, [[0, 0, 0], [1, 0, 0, 0]], [90, [0,
0, 200], [1, 0, 0, 0], 0.6, 0.6, 0.6]];
PERS tooldata P66:= [ TRUE, [[0, 0, 0], [1, 0, 0, 0]], [60, [0, 0,
133], [1, 0, 0, 0], 0.27, 0.27, 0.27]];
PERS tooldata P33:= [ TRUE, [[0, 0, 0], [1, 0, 0, 0]], [30, [0, 0,
67], [1, 0, 0, 0], 0.067, 0.067, 0.067]];

```

## Category 0

The following table describes the stopping distance and time for category 0 stop.

Axis	Distance	Stop time
1	46.9°	0.55 s
2	28.9°	0.37 s
3	30.5°	0.35 s

## Category 1, extension zones

For definitions of the zones, see [Extension zones on page 84](#).

The zone border is the mounting interface location for axis 2 and axis 3.

## Axis 1

Zone border	Axis 2	Axis 3
z0-z1	-42°	42°
z1-z2	6°	-6°

## Axis 2

Zone border	Axis 2	Axis 3
z0-z1	48°	30°
z1-z2	90°	-30°

## Axis 3

Only one zone exists.

*Continues on next page*

## 2 Technical data for IRB 5710

### 2.11.5 IRB 5710-90/2.7

Continued

#### Category 1, Axis 1, Extension zone 0, stopping distance and stopping time

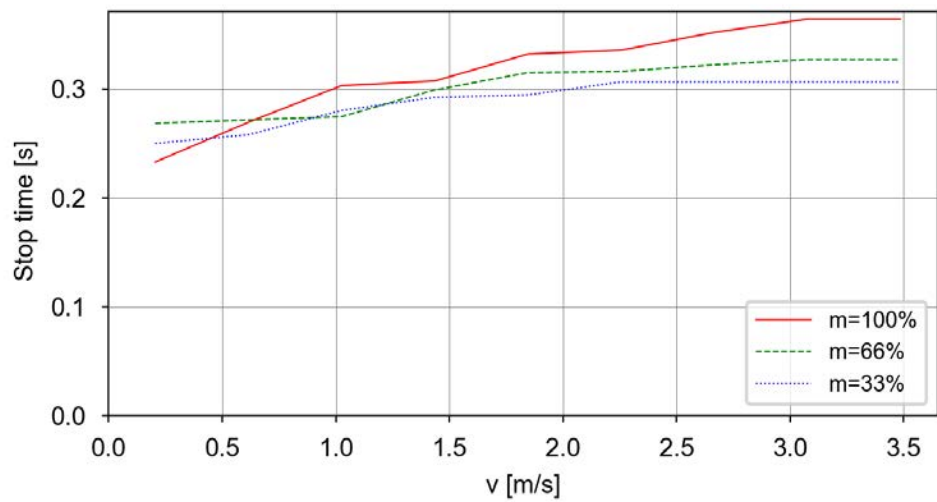
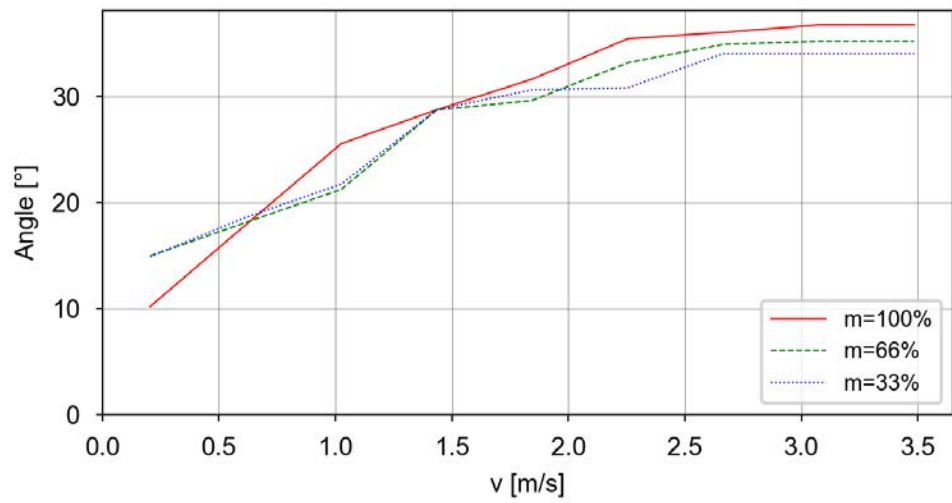

Continues on next page

Category 1, Axis 1, Extension zone 1, stopping distance and stopping time

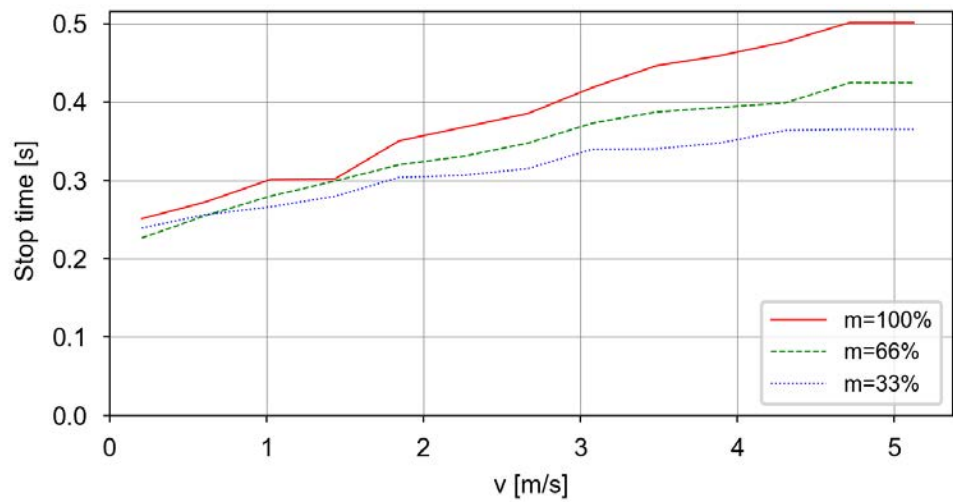
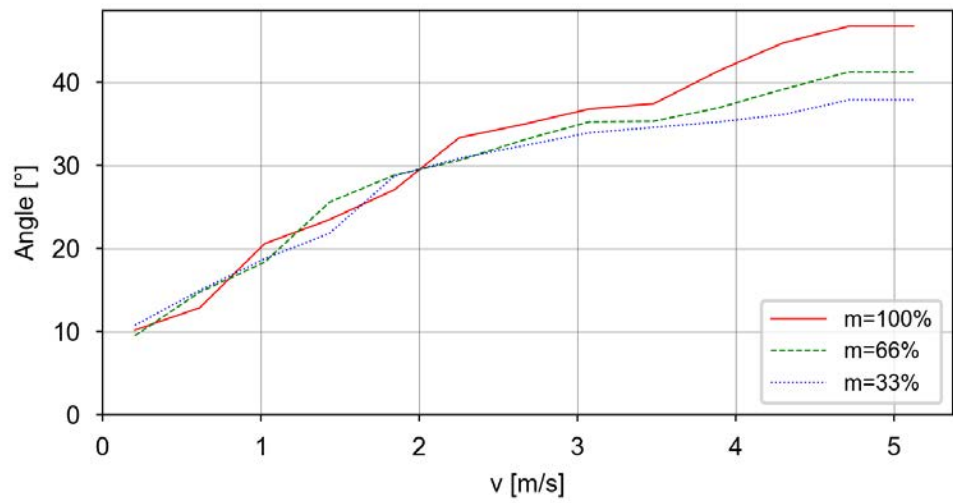

Continues on next page

## 2 Technical data for IRB 5710

### 2.11.5 IRB 5710-90/2.7

Continued

#### Category 1, Axis 1, Extension zone 2, stopping distance and stopping time

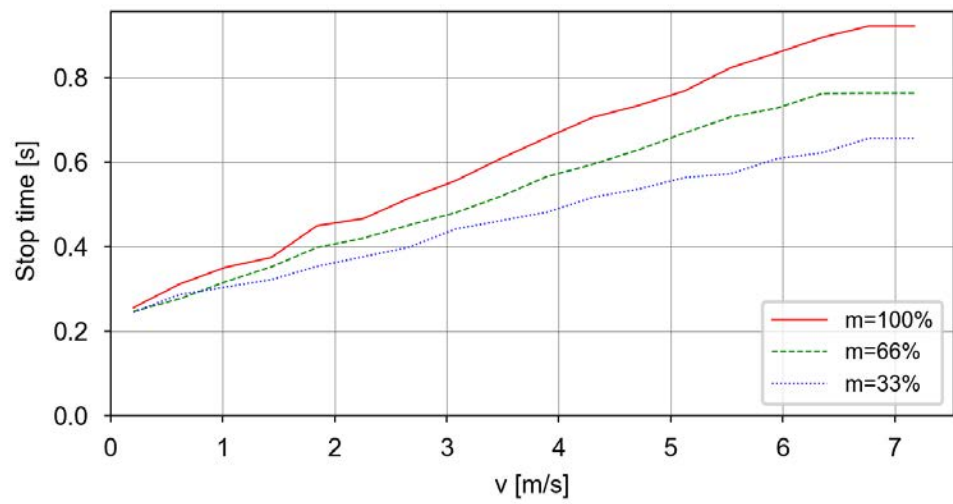
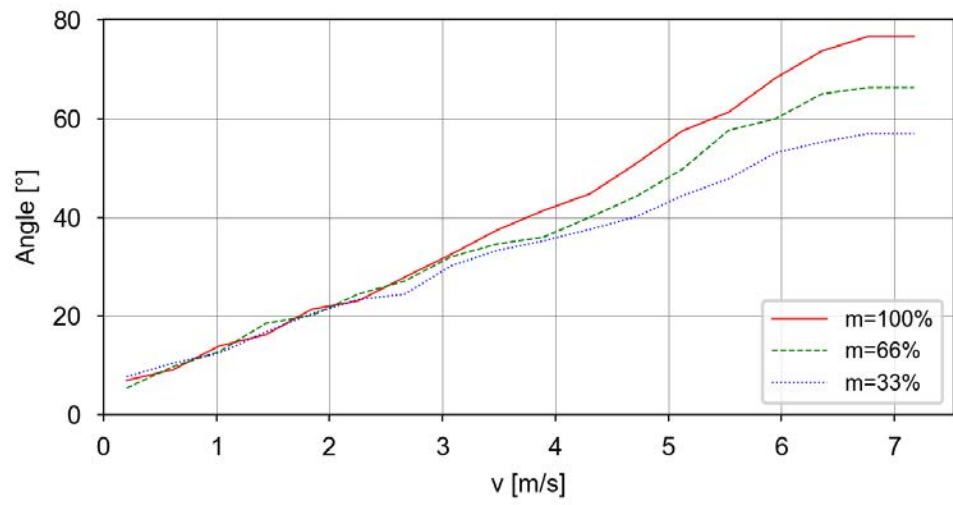

Continues on next page

Category 1, Axis 2, Extension zone 0, stopping distance and stopping time

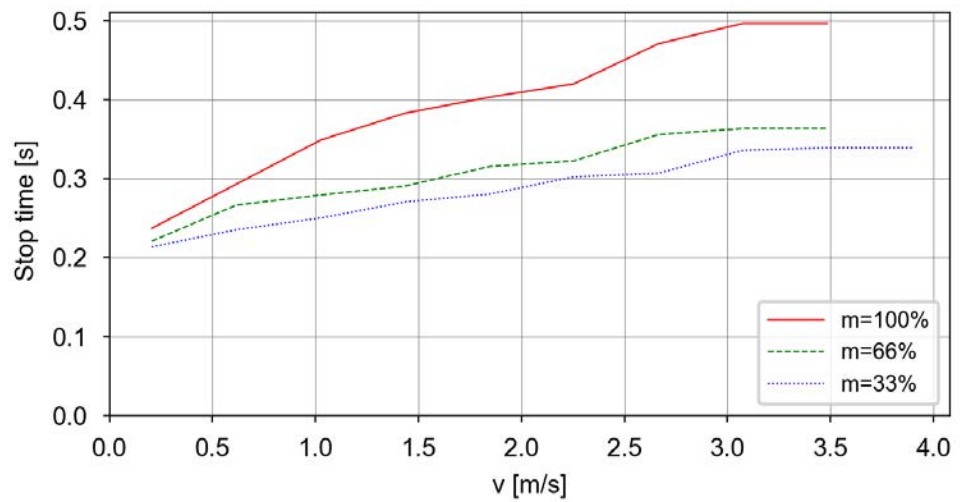
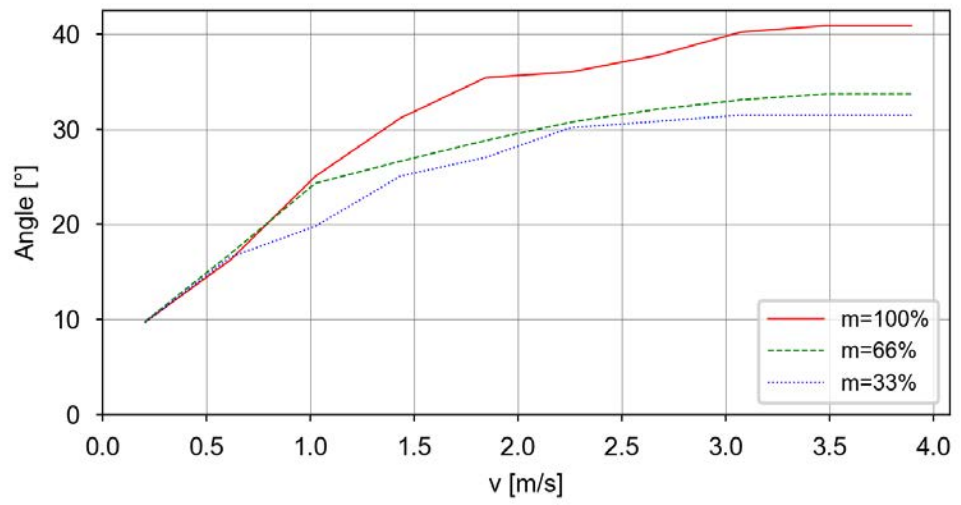

Continues on next page

## 2 Technical data for IRB 5710

### 2.11.5 IRB 5710-90/2.7

Continued

#### Category 1, Axis 2, Extension zone 1, stopping distance and stopping time

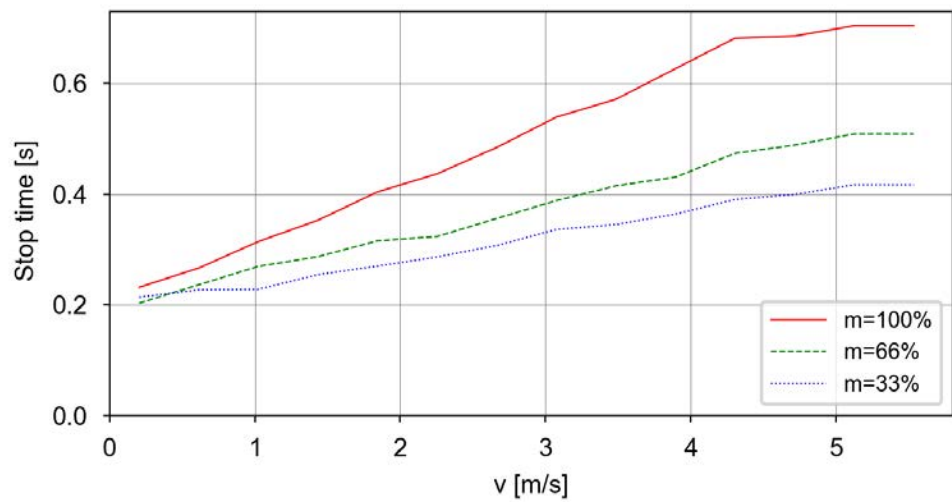
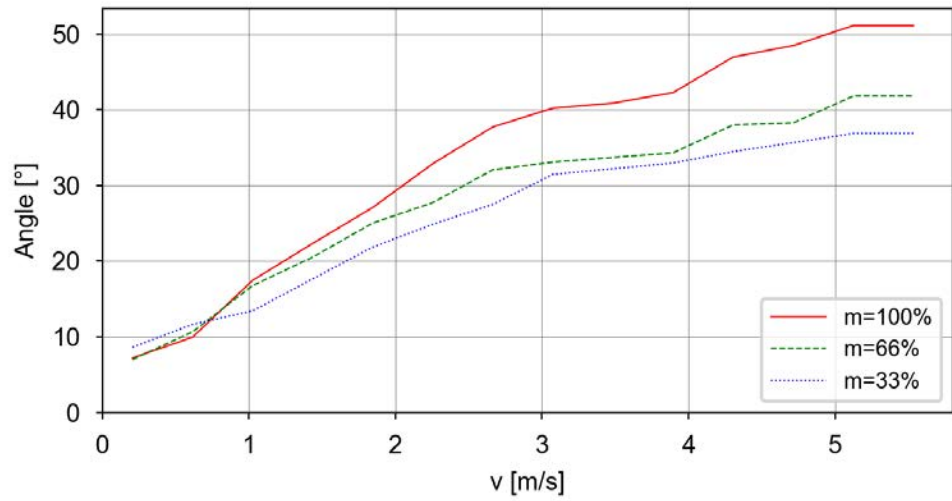

Continues on next page

Category 1, Axis 2, Extension zone 2, stopping distance and stopping time

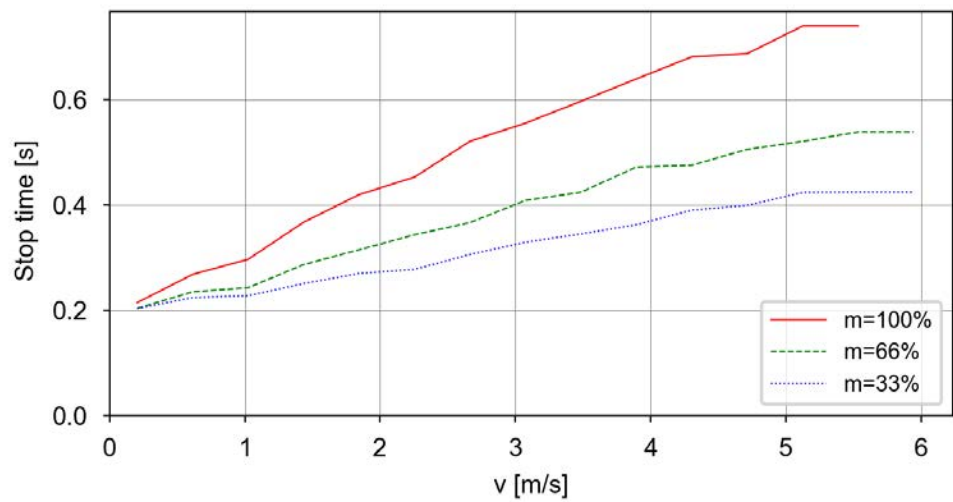
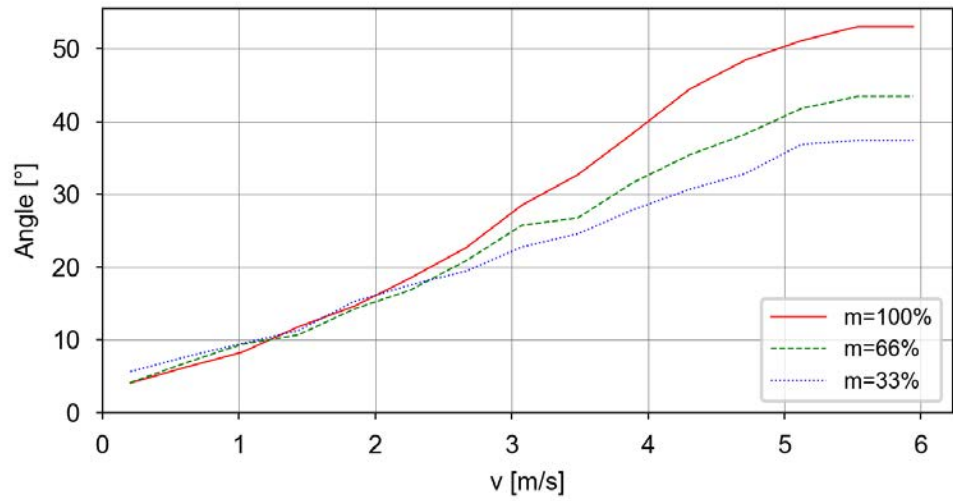

Continues on next page

## 2 Technical data for IRB 5710

### 2.11.5 IRB 5710-90/2.7

Continued

#### Category 1, Axis 3, Extension zone 0, stopping distance and stopping time

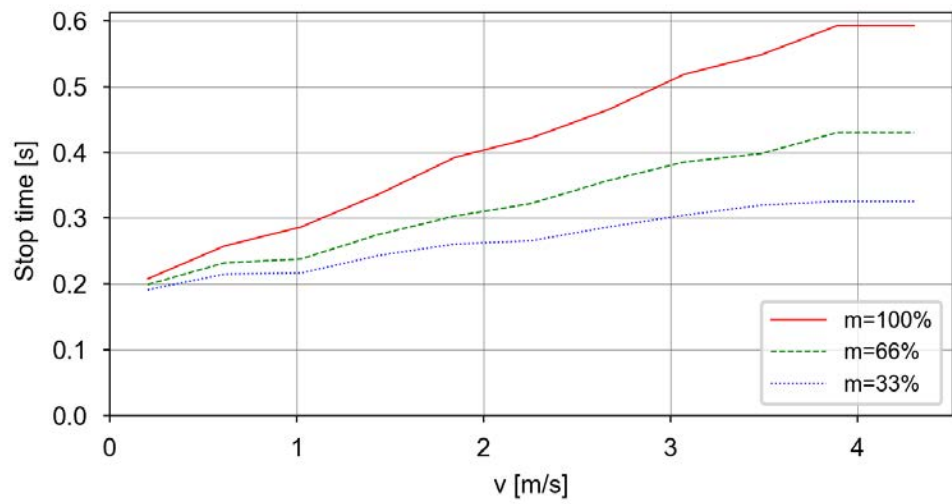
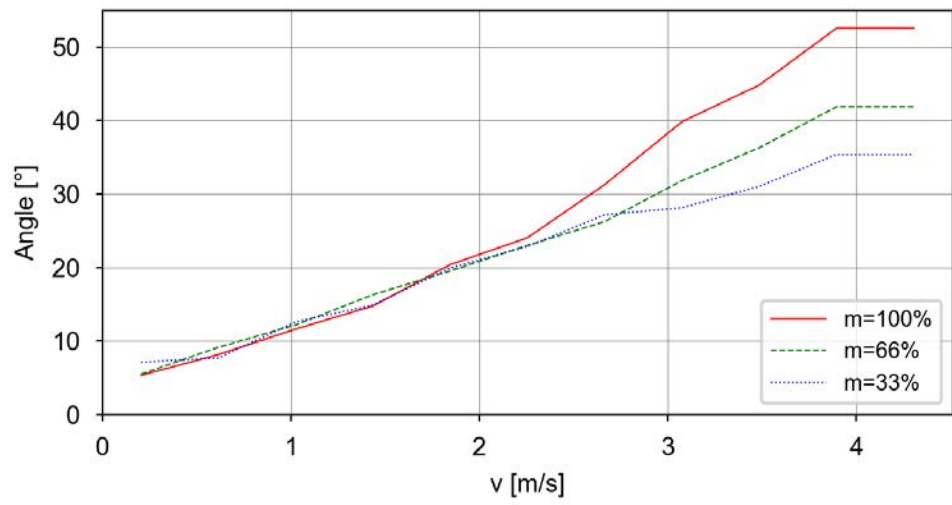



## 2.11.6 IRB 5710-90/2.7 Inv

## Used tooldata

```

PERS tooldata P100:= [ TRUE, [[0, 0, 0], [1, 0, 0, 0]], [90, [0,
0, 200], [1, 0, 0, 0], 0.6, 0.6, 0.6]];
PERS tooldata P66:= [ TRUE, [[0, 0, 0], [1, 0, 0, 0]], [60, [0, 0,
133], [1, 0, 0, 0], 0.27, 0.27, 0.27]];
PERS tooldata P33:= [ TRUE, [[0, 0, 0], [1, 0, 0, 0]], [30, [0, 0,
67], [1, 0, 0, 0], 0.067, 0.067, 0.067]];

```

## Category 0

The following table describes the stopping distance and time for category 0 stop.

Axis	Distance	Stop time
1	46.9°	0.55 s
2	28.5°	0.38 s
3	31.6°	0.35 s

## Category 1, extension zones

For definitions of the zones, see [Extension zones on page 84](#).

The zone border is the mounting interface location for axis 2 and axis 3.

## Axis 1

Zone border	Axis 2	Axis 3
z0-z1	-42°	42°
z1-z2	6°	-6°

## Axis 2

Zone border	Axis 2	Axis 3
z0-z1	48°	30°
z1-z2	90°	-30°

## Axis 3

Only one zone exists.

*Continues on next page*

## 2 Technical data for IRB 5710

### 2.11.6 IRB 5710-90/2.7 Inv

Continued

#### Category 1, Axis 1, Extension zone 0, stopping distance and stopping time

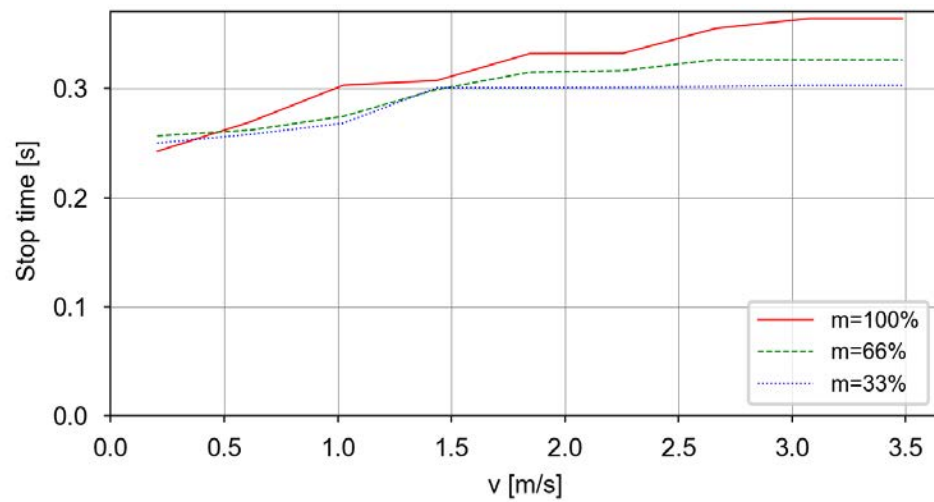
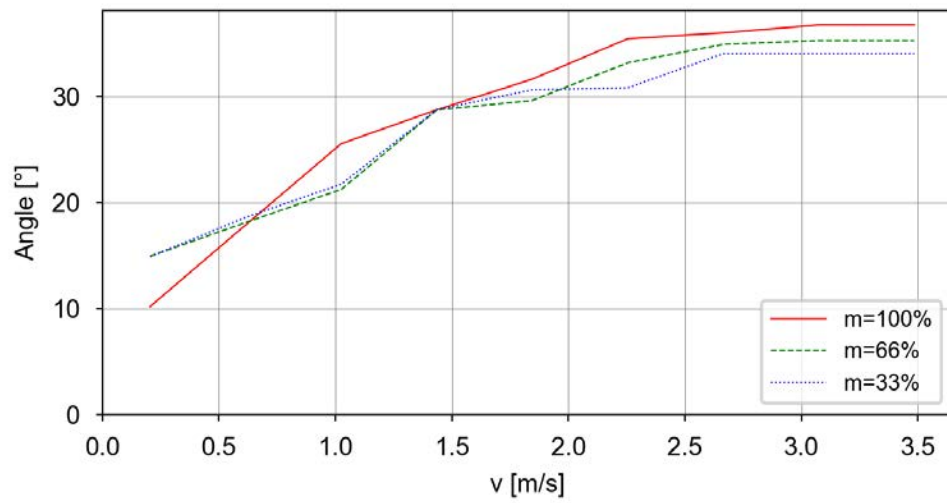

Continues on next page

Category 1, Axis 1, Extension zone 1, stopping distance and stopping time

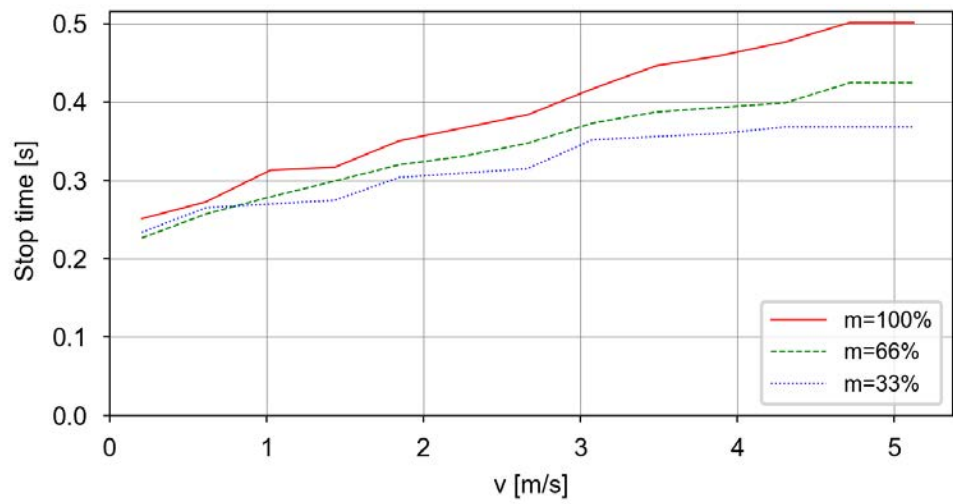
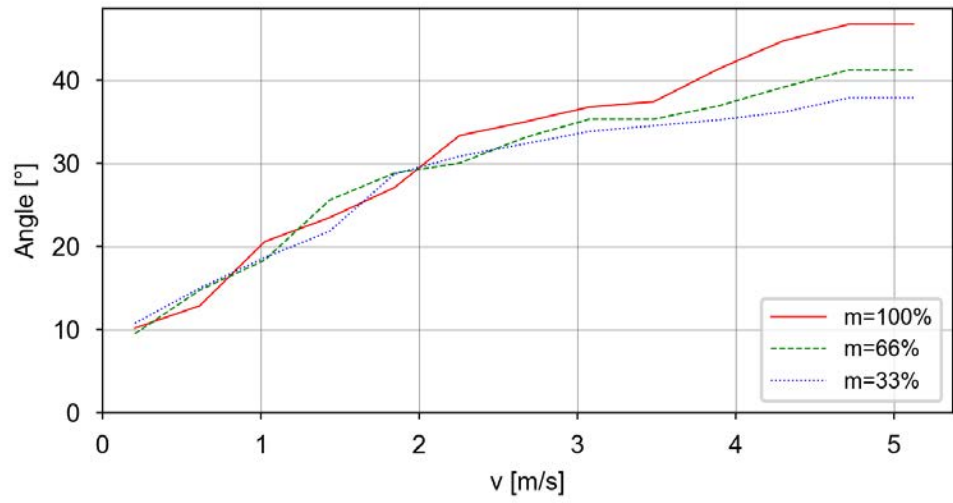

Continues on next page

## 2 Technical data for IRB 5710

### 2.11.6 IRB 5710-90/2.7 Inv

Continued

#### Category 1, Axis 1, Extension zone 2, stopping distance and stopping time

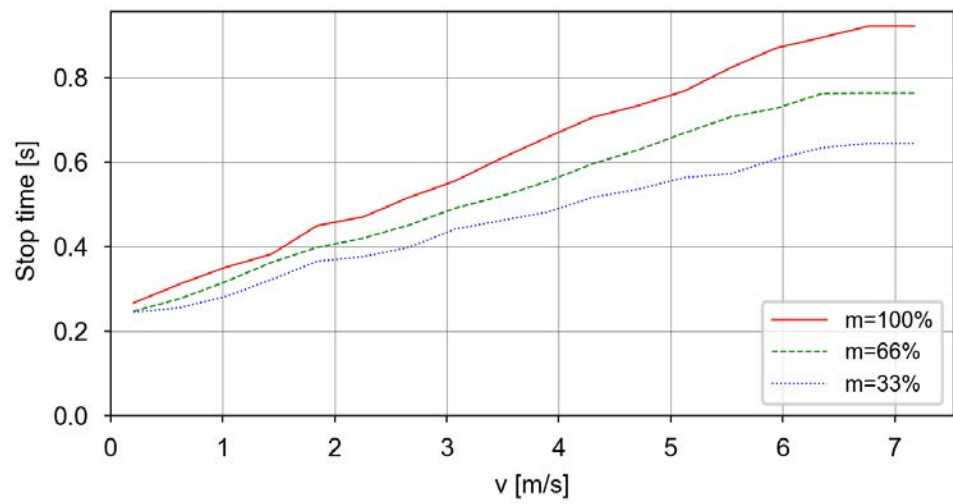
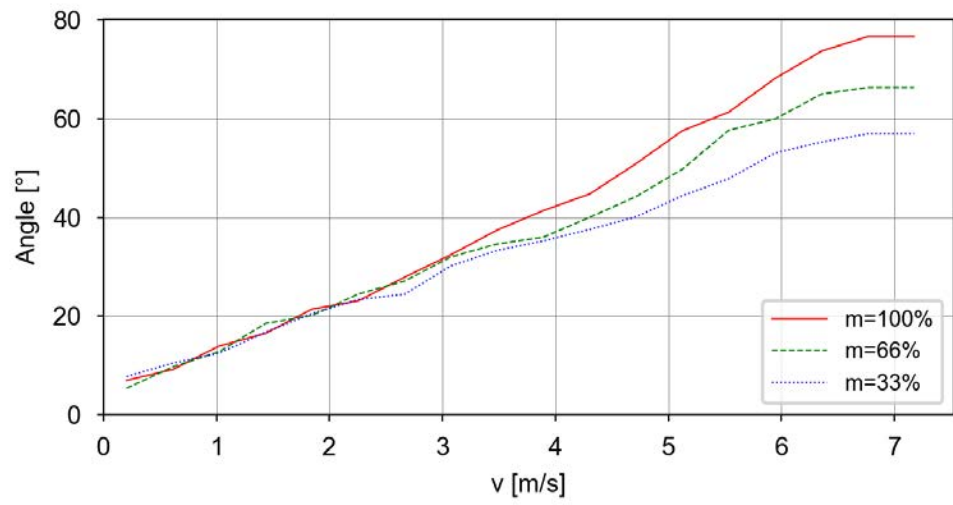

Continues on next page

Category 1, Axis 2, Extension zone 0, stopping distance and stopping time

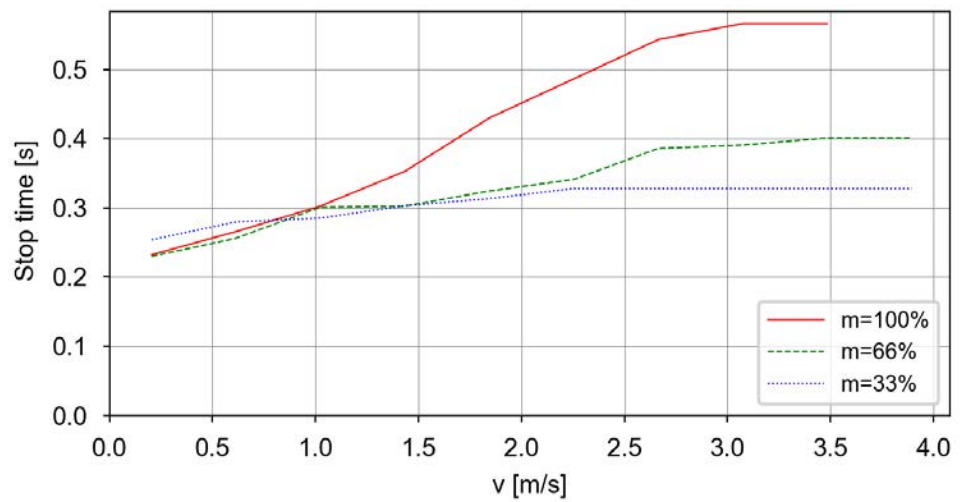
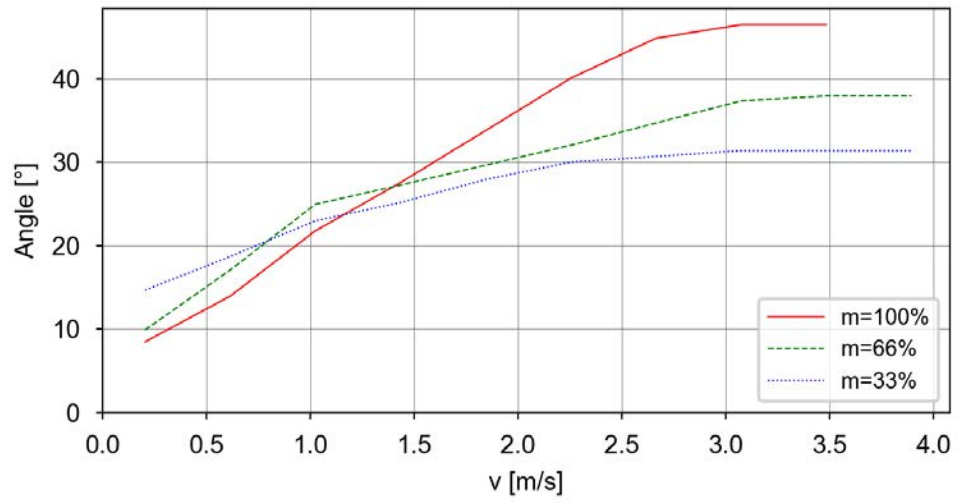

Continues on next page

## 2 Technical data for IRB 5710

### 2.11.6 IRB 5710-90/2.7 Inv

Continued

#### Category 1, Axis 2, Extension zone 1, stopping distance and stopping time

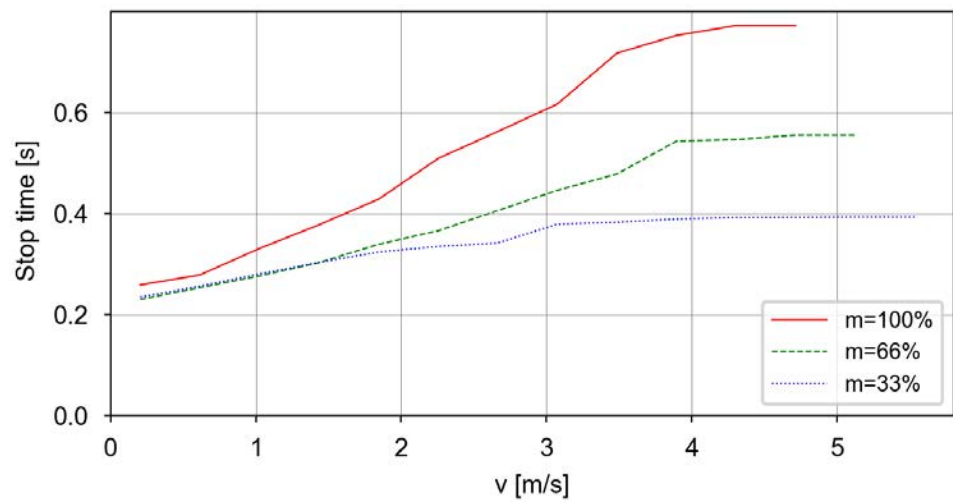
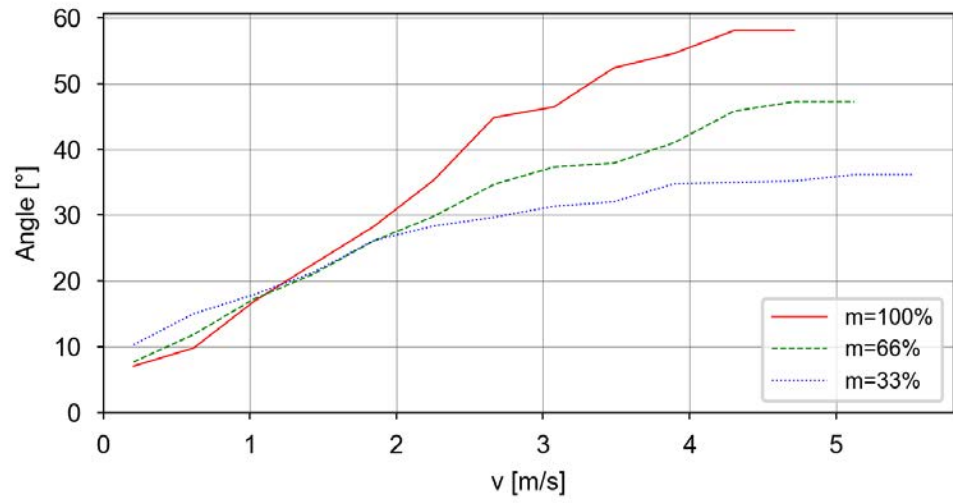

Continues on next page

Category 1, Axis 2, Extension zone 2, stopping distance and stopping time

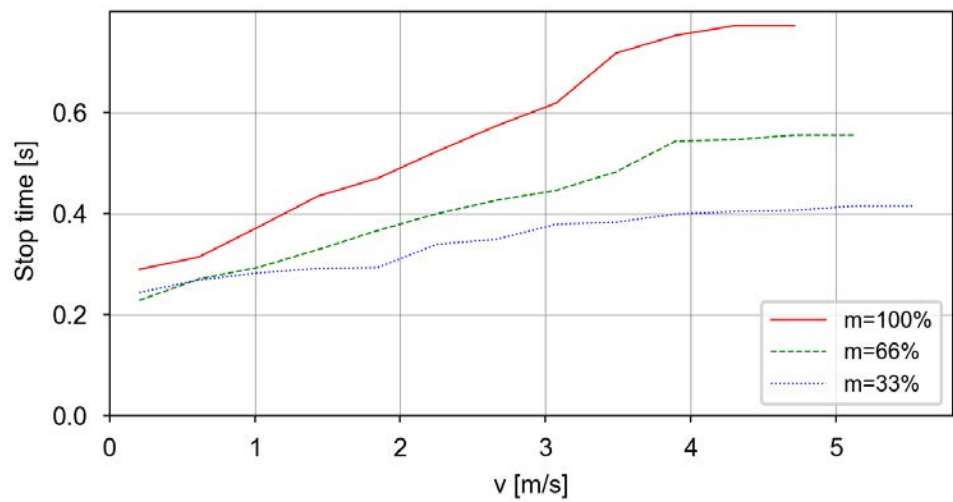
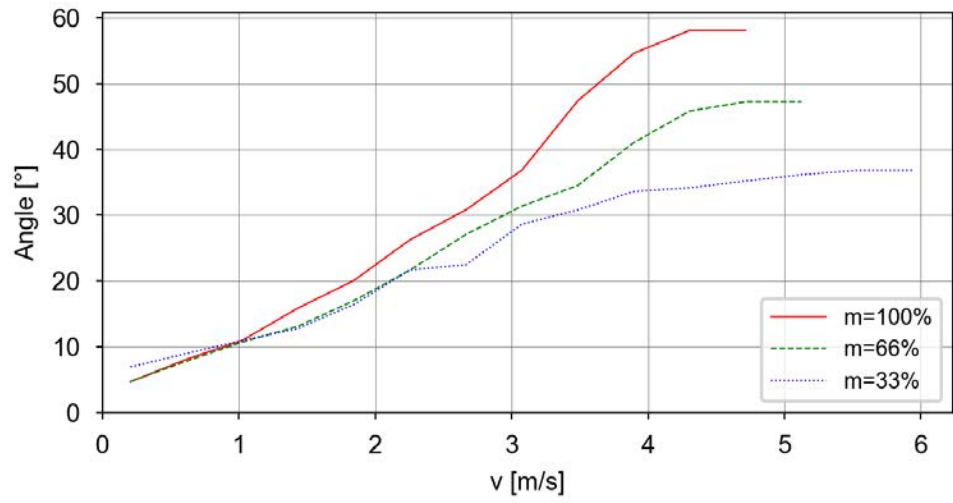

Continues on next page

## 2 Technical data for IRB 5710

### 2.11.6 IRB 5710-90/2.7 Inv

Continued

#### Category 1, Axis 3, Extension zone 0, stopping distance and stopping time

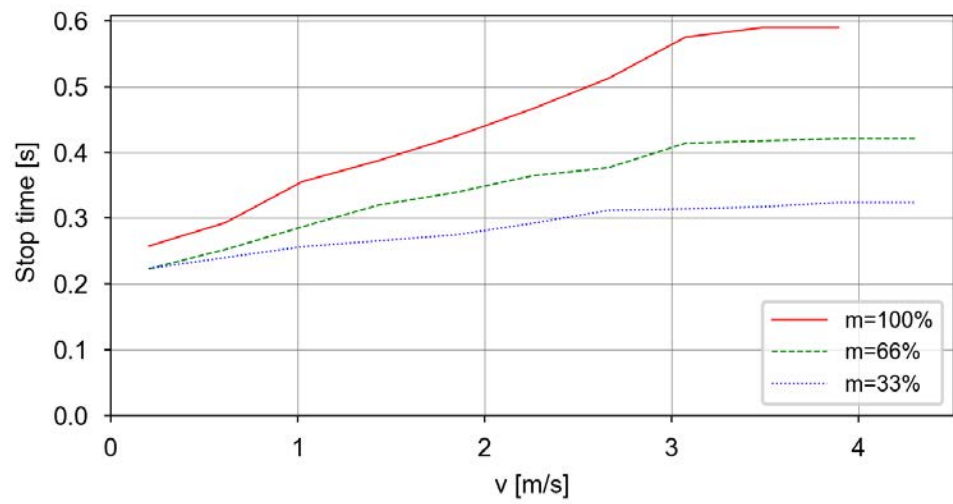
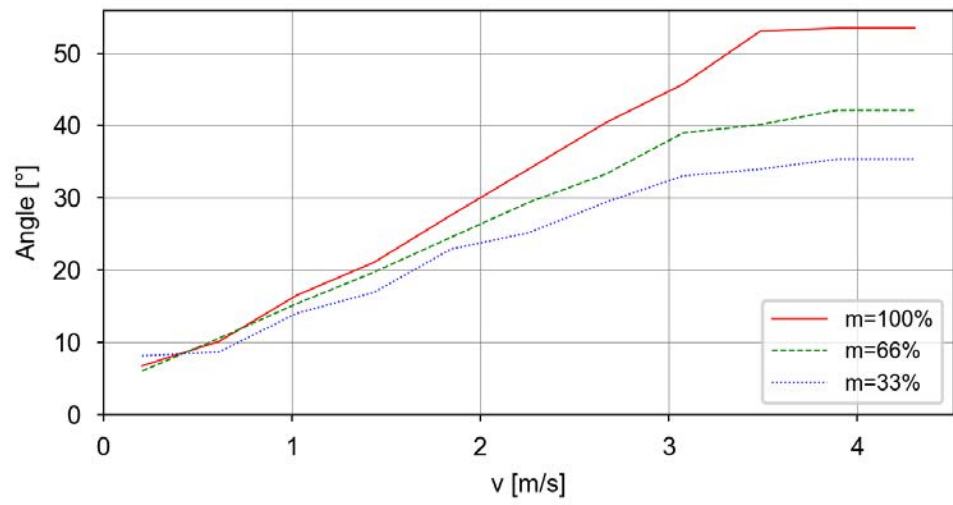



## 2.11.7 IRB 5710-90/2.3 LID

## Used tooldata

```
PERS tooldata P100:= [ TRUE, [[0, 0, 0], [1, 0, 0, 0]], [90, [0,
0, 300], [1, 0, 0, 0], 1.4, 1.4, 1.4]];
PERS tooldata P66:= [ TRUE, [[0, 0, 0], [1, 0, 0, 0]], [60, [0, 0,
200], [1, 0, 0, 0], 0.6, 0.6, 0.6]];
PERS tooldata P33:= [ TRUE, [[0, 0, 0], [1, 0, 0, 0]], [30, [0, 0,
100], [1, 0, 0, 0], 0.15, 0.15, 0.15]];

```

## Category 0

The following table describes the stopping distance and time for category 0 stop.

Axis	Distance	Stop time
1	48.1°	0.56 s
2	28.3°	0.36 s
3	29.1°	0.32 s

## Category 1, extension zones

For definitions of the zones, see [Extension zones on page 84](#).

The zone border is the mounting interface location for axis 2 and axis 3.

## Axis 1

Zone border	Axis 2	Axis 3
z0-z1	-42°	42°
z1-z2	6°	-6°

## Axis 2

Zone border	Axis 2	Axis 3
z0-z1	48°	30°
z1-z2	90°	-30°

## Axis 3

Only one zone exists.

*Continues on next page*

## 2 Technical data for IRB 5710

### 2.11.7 IRB 5710-90/2.3 LID

Continued

#### Category 1, Axis 1, Extension zone 0, stopping distance and stopping time

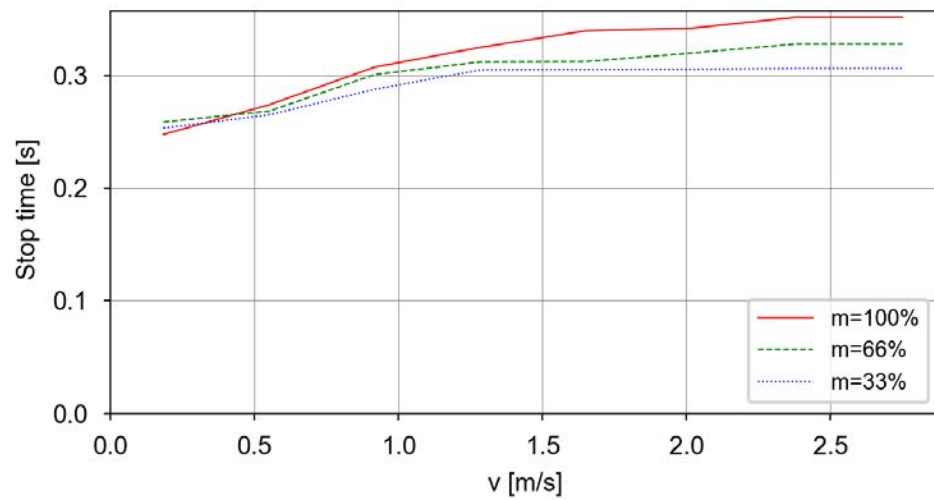
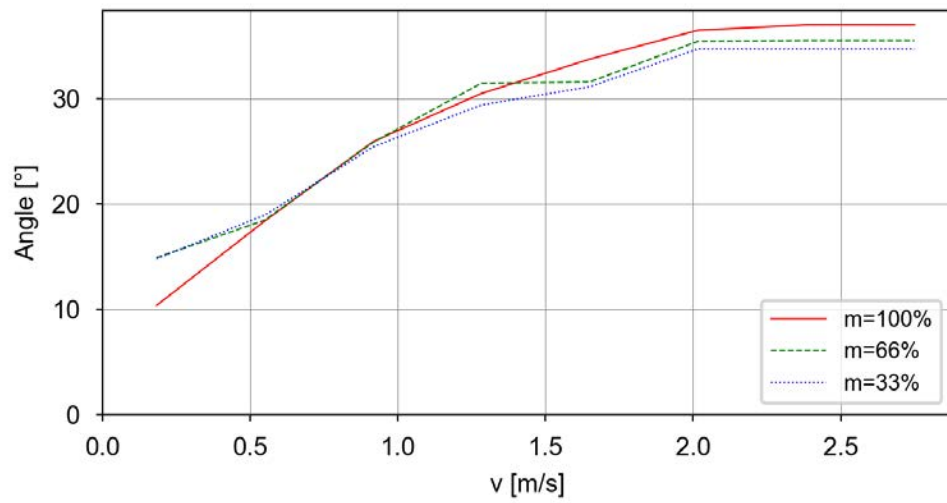

Continues on next page

Category 1, Axis 1, Extension zone 1, stopping distance and stopping time

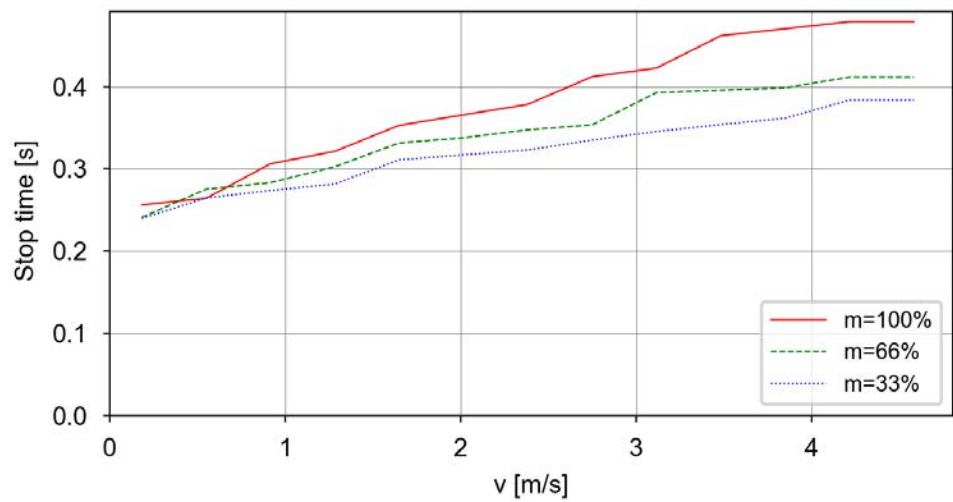
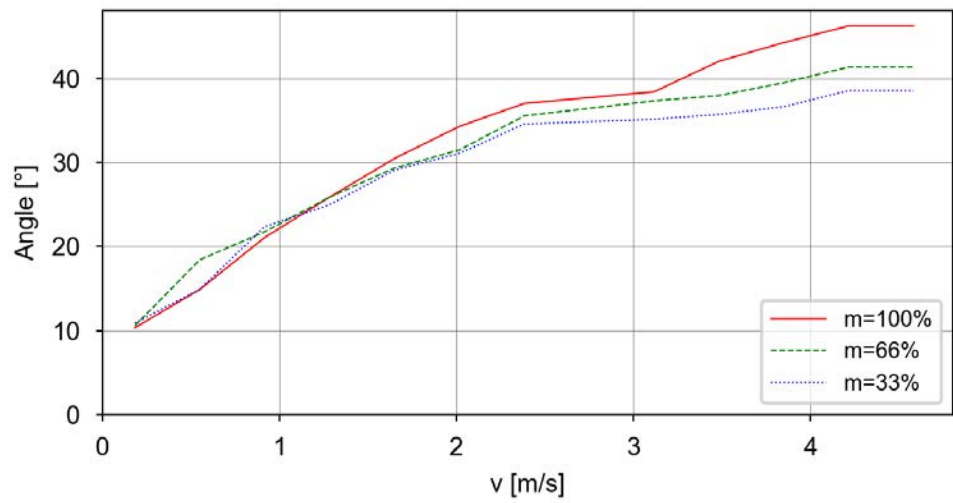

Continues on next page

## 2 Technical data for IRB 5710

### 2.11.7 IRB 5710-90/2.3 LID

Continued

#### Category 1, Axis 1, Extension zone 2, stopping distance and stopping time

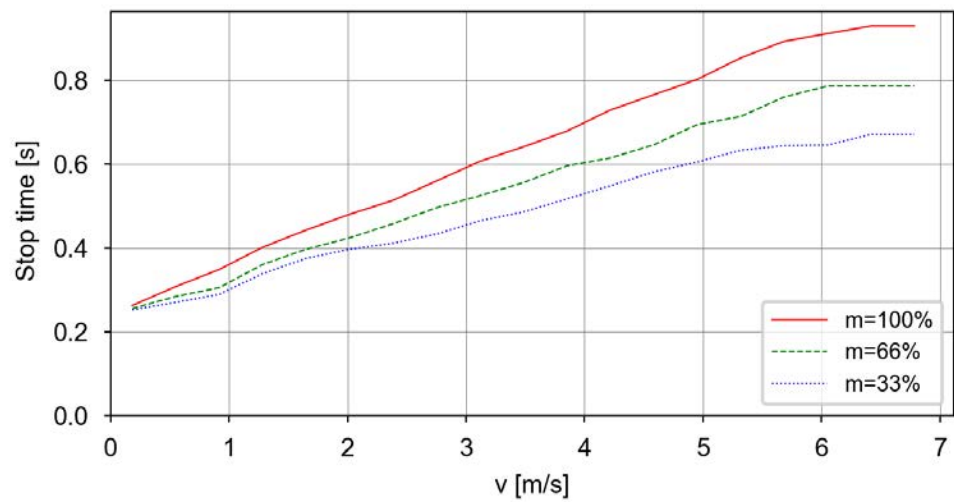
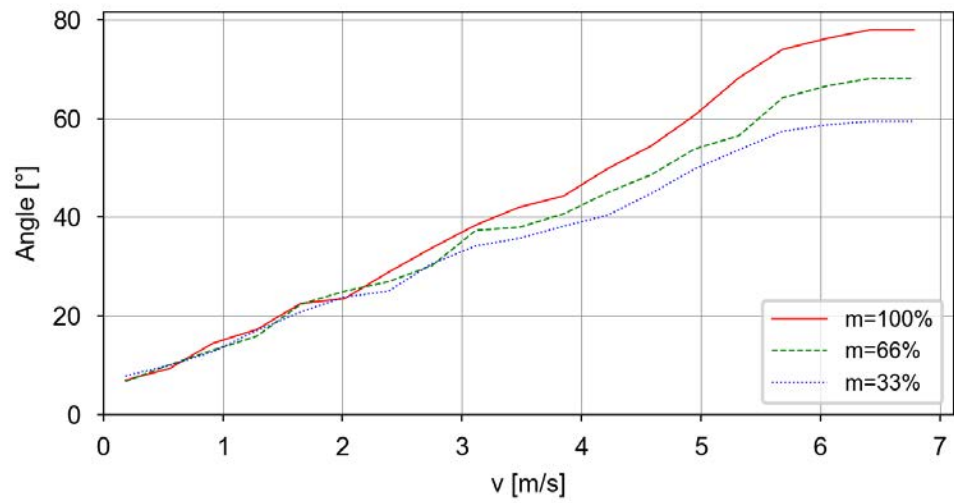

Continues on next page

Category 1, Axis 2, Extension zone 0, stopping distance and stopping time

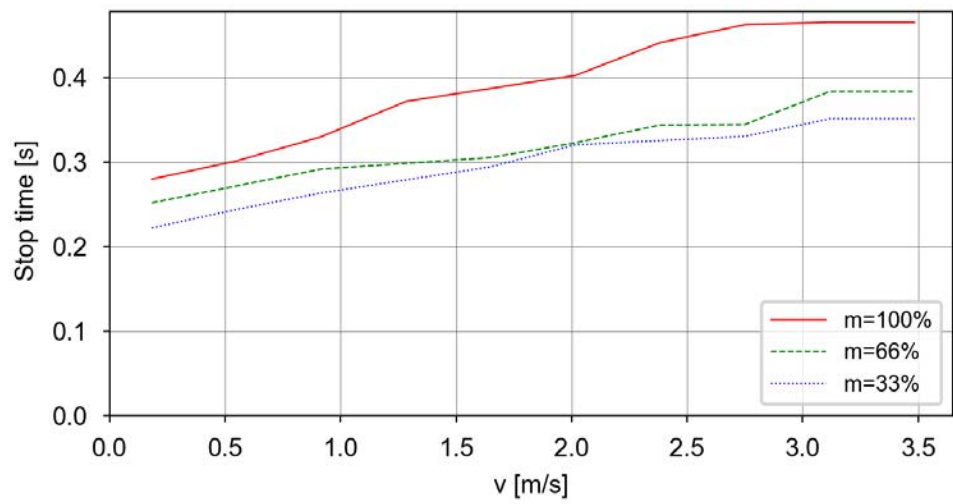
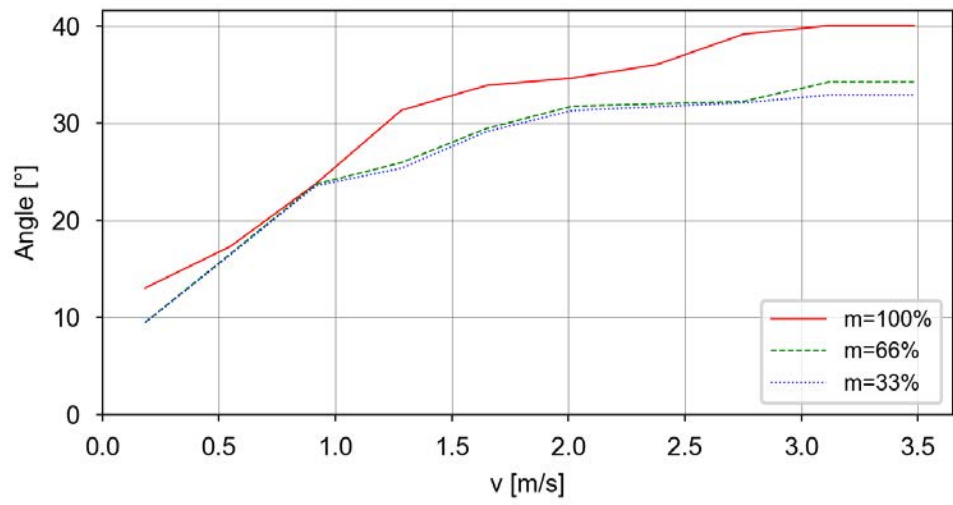

Continues on next page

## 2 Technical data for IRB 5710

### 2.11.7 IRB 5710-90/2.3 LID

Continued

#### Category 1, Axis 2, Extension zone 1, stopping distance and stopping time

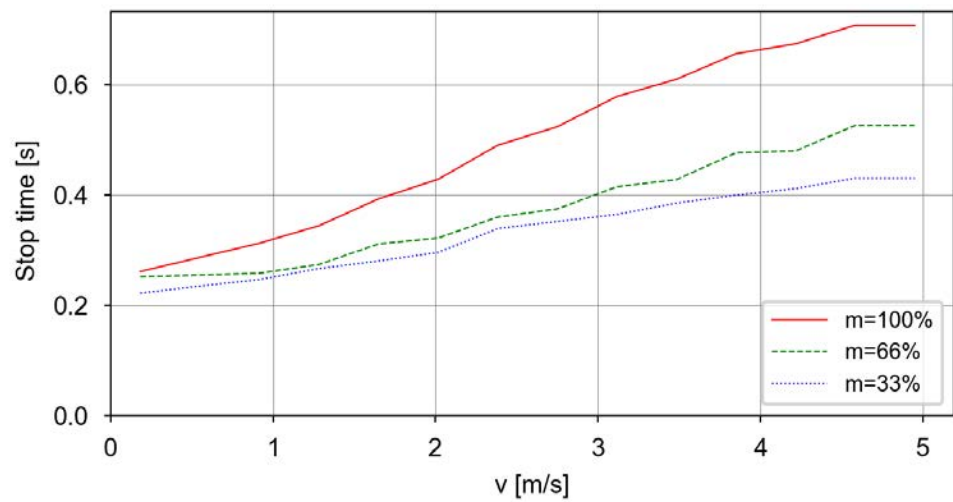
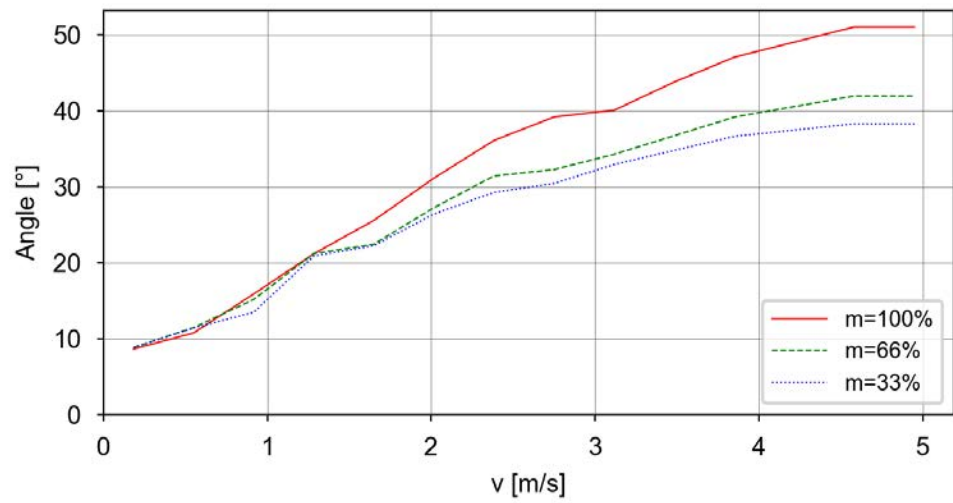

Continues on next page

Category 1, Axis 2, Extension zone 2, stopping distance and stopping time

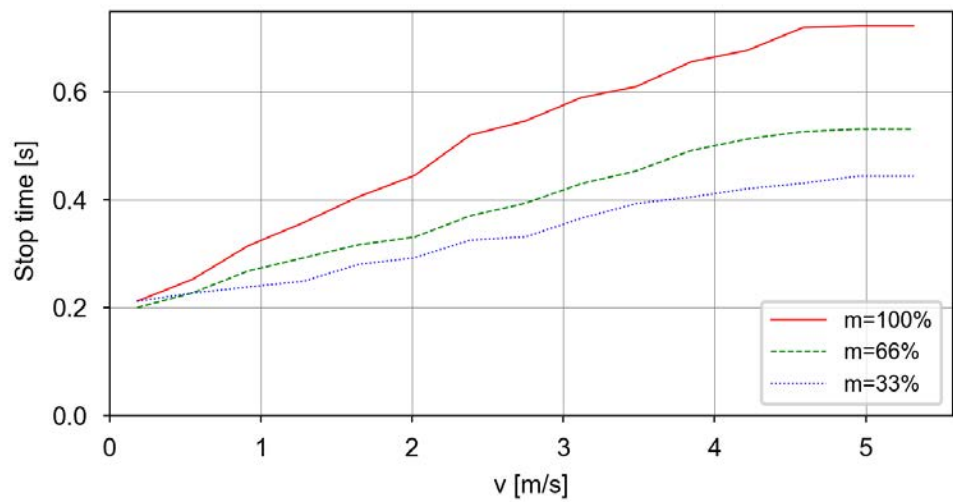
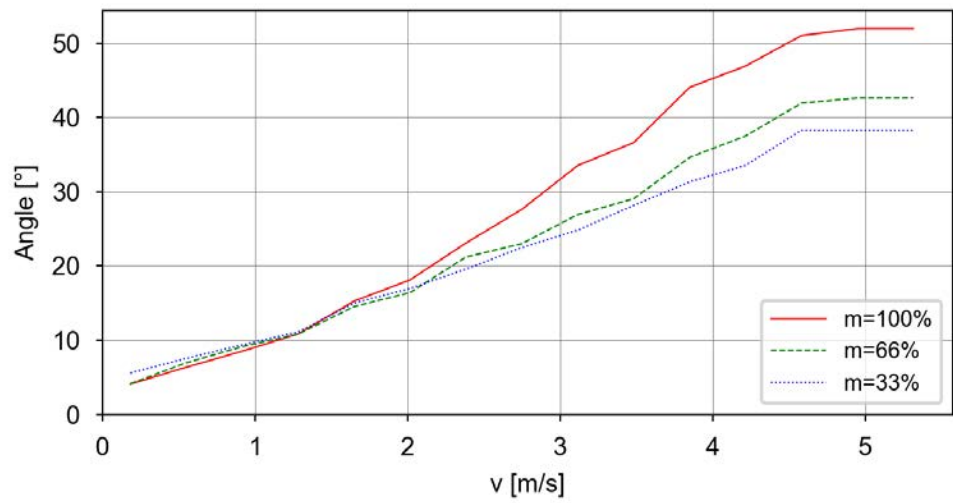

Continues on next page

## 2 Technical data for IRB 5710

### 2.11.7 IRB 5710-90/2.3 LID

Continued

#### Category 1, Axis 3, Extension zone 0, stopping distance and stopping time

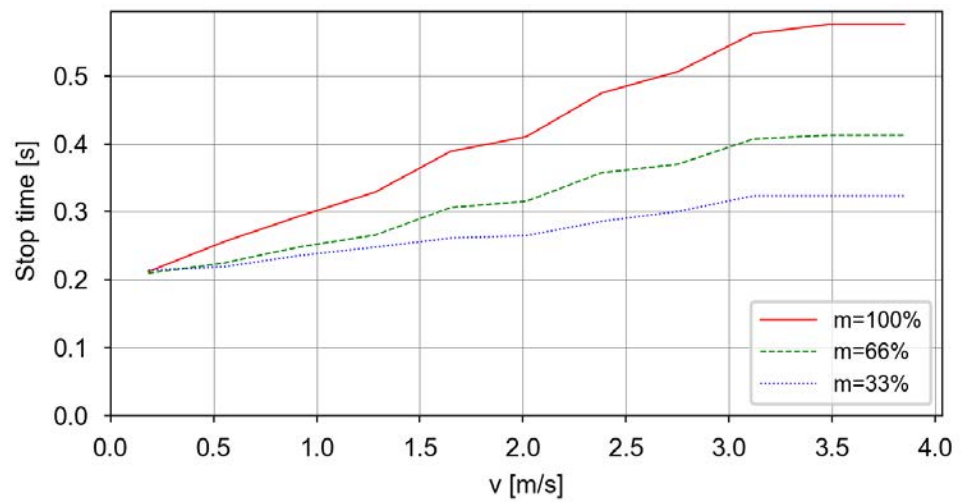
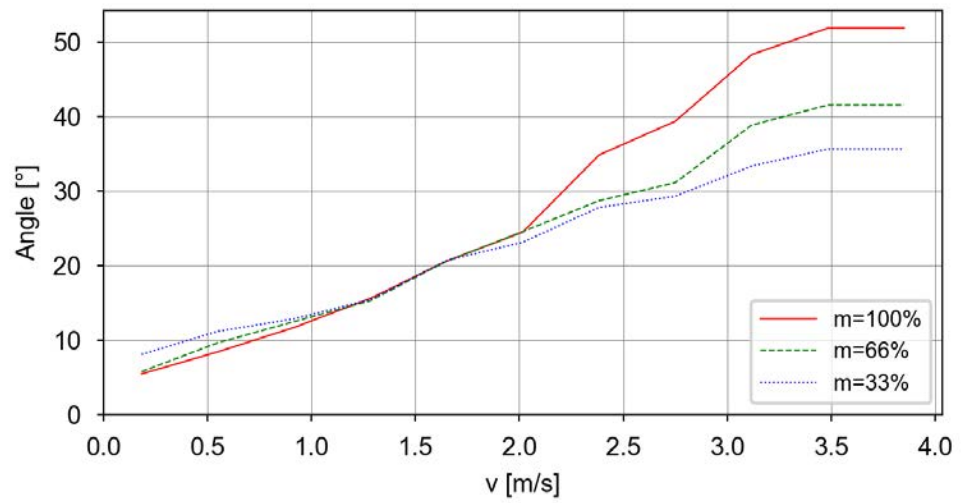



## 2.11.8 IRB 5710-90/2.3 LID Inv

### Used tooldata

```
PERS tooldata P100:= [ TRUE, [[0, 0, 0], [1, 0, 0, 0]], [90, [0,
0, 300], [1, 0, 0, 0], 1.4, 1.4, 1.4]];
PERS tooldata P66:= [ TRUE, [[0, 0, 0], [1, 0, 0, 0]], [60, [0, 0,
200], [1, 0, 0, 0], 0.6, 0.6, 0.6]];
PERS tooldata P33:= [ TRUE, [[0, 0, 0], [1, 0, 0, 0]], [30, [0, 0,
100], [1, 0, 0, 0], 0.15, 0.15, 0.15]];

```

### Category 0

The following table describes the stopping distance and time for category 0 stop.

Axis	Distance	Stop time
1	48.1°	0.56 s
2	27.6°	0.36 s
3	30.1°	0.33 s

### Category 1, extension zones

For definitions of the zones, see [Extension zones on page 84](#).

The zone border is the mounting interface location for axis 2 and axis 3.

#### Axis 1

Zone border	Axis 2	Axis 3
z0-z1	-42°	42°
z1-z2	6°	-6°

#### Axis 2

Zone border	Axis 2	Axis 3
z0-z1	48°	30°
z1-z2	90°	-30°

#### Axis 3

Only one zone exists.

*Continues on next page*

## 2 Technical data for IRB 5710

### 2.11.8 IRB 5710-90/2.3 LID Inv

Continued

#### Category 1, Axis 1, Extension zone 0, stopping distance and stopping time

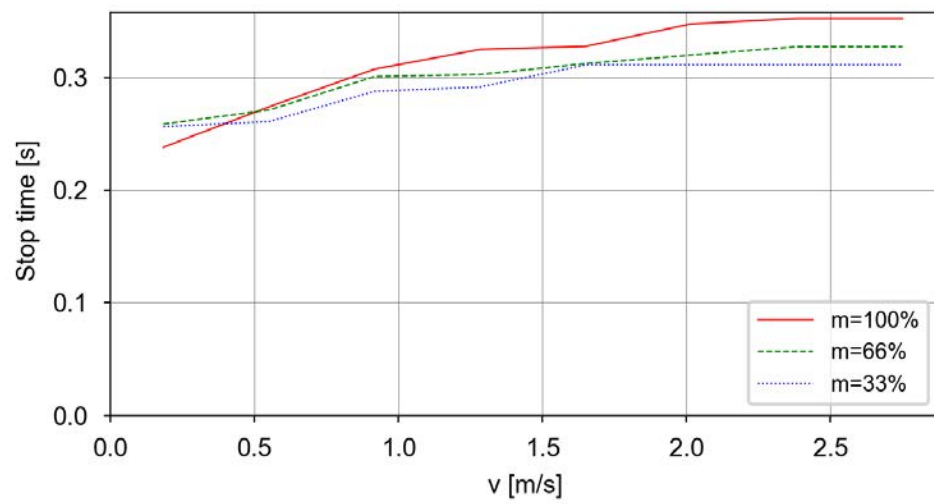
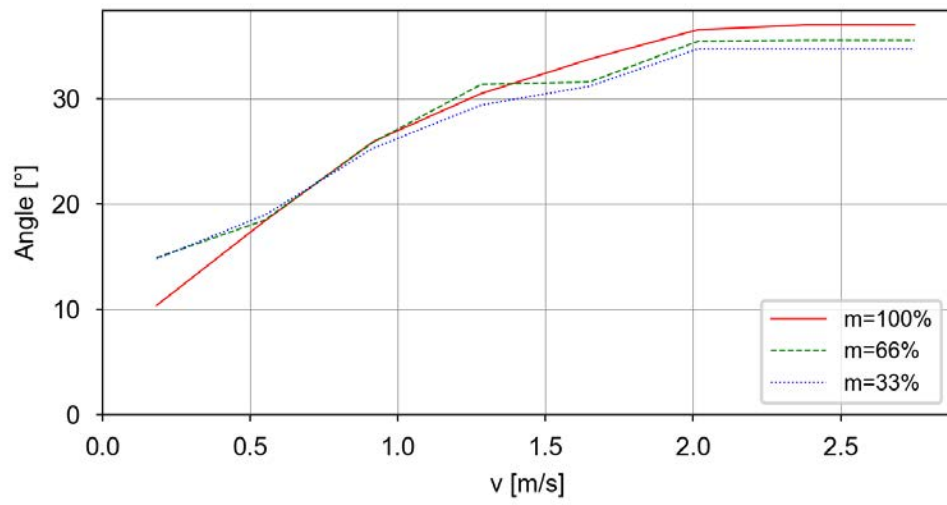

Continues on next page

Category 1, Axis 1, Extension zone 1, stopping distance and stopping time

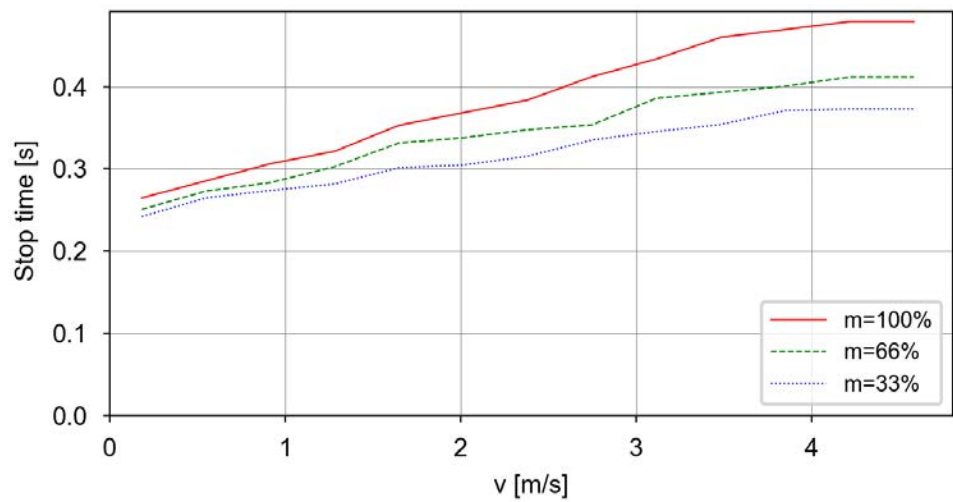
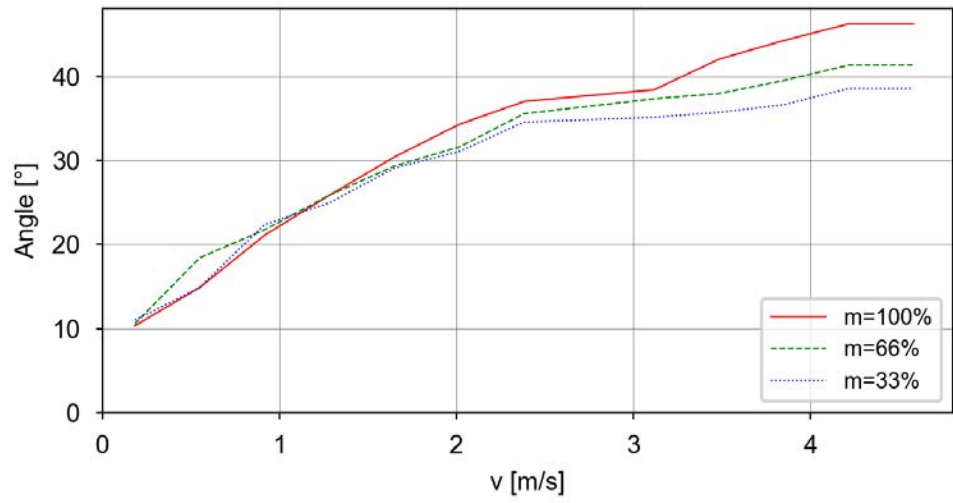

Continues on next page

## 2 Technical data for IRB 5710

### 2.11.8 IRB 5710-90/2.3 LID Inv

Continued

#### Category 1, Axis 1, Extension zone 2, stopping distance and stopping time

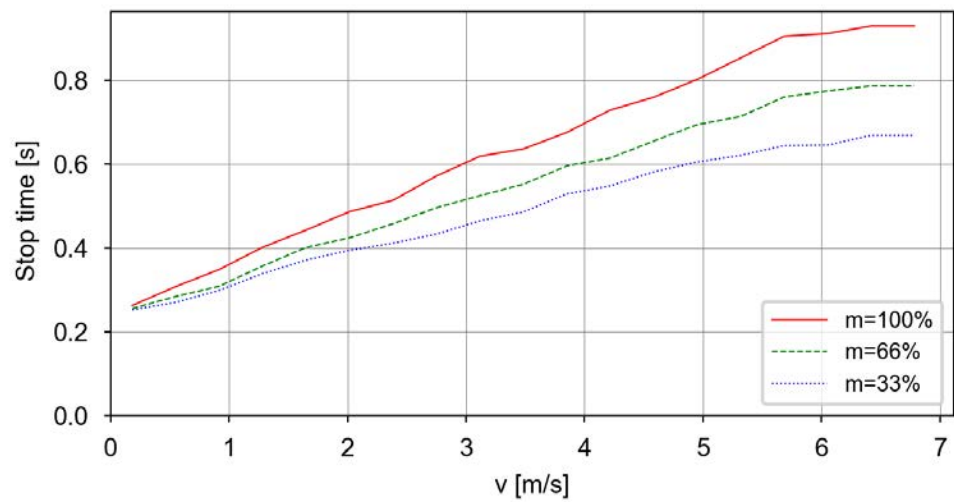
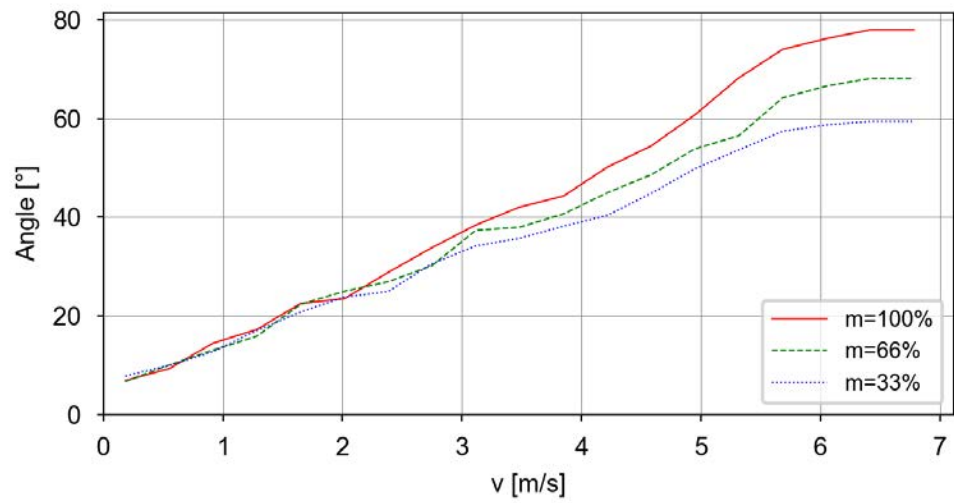

Continues on next page

Category 1, Axis 2, Extension zone 0, stopping distance and stopping time

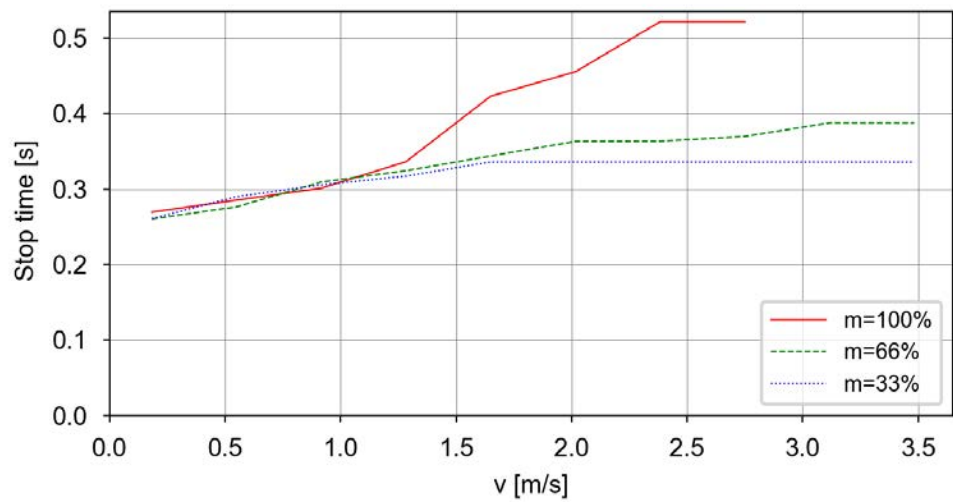
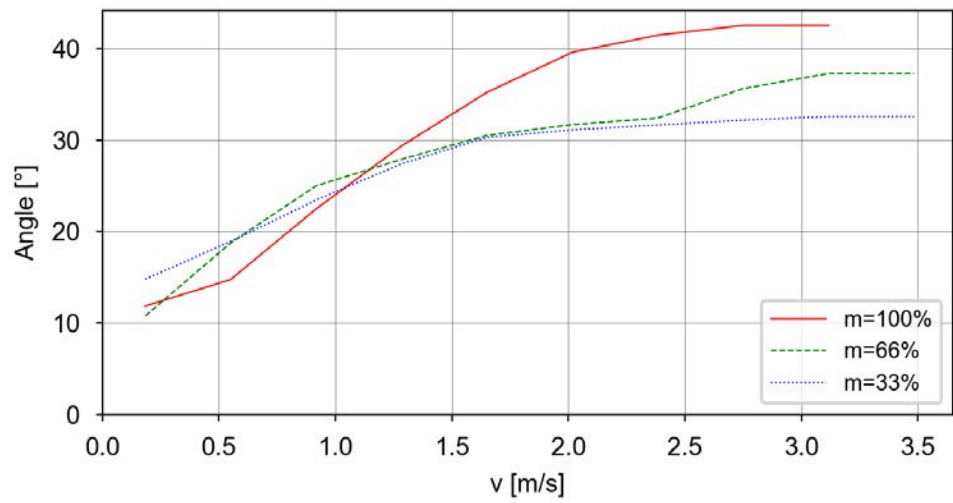

Continues on next page

## 2 Technical data for IRB 5710

### 2.11.8 IRB 5710-90/2.3 LID Inv

Continued

#### Category 1, Axis 2, Extension zone 1, stopping distance and stopping time

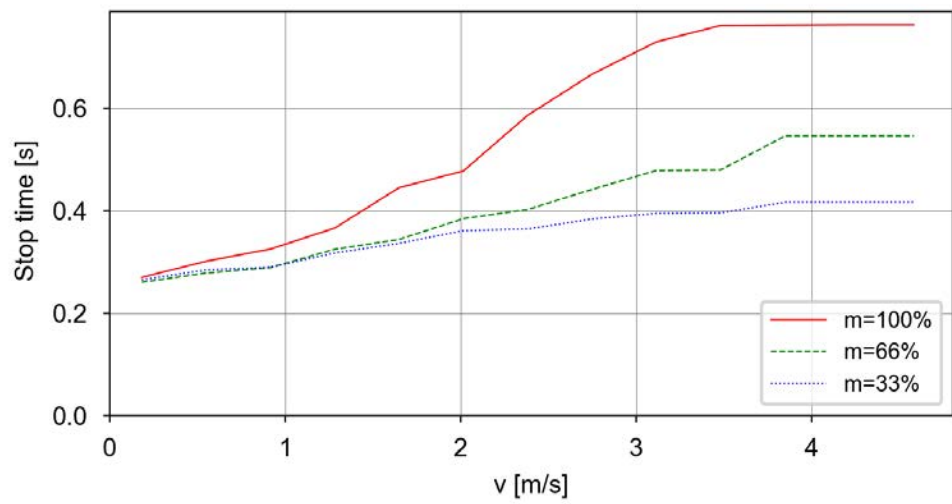
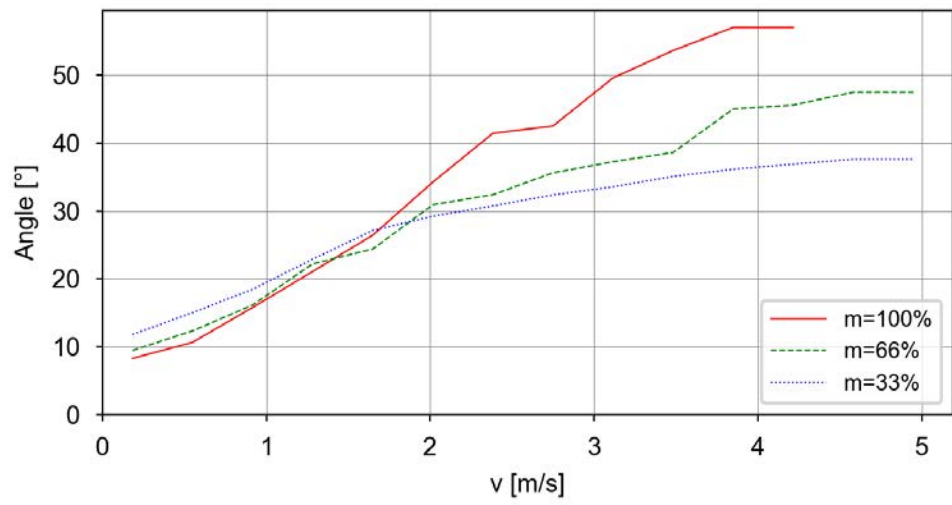

Continues on next page

Category 1, Axis 2, Extension zone 2, stopping distance and stopping time

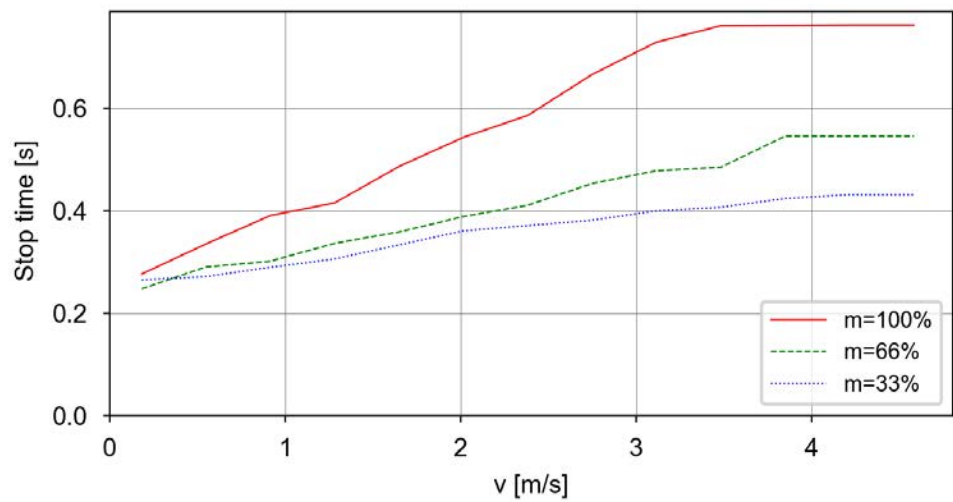
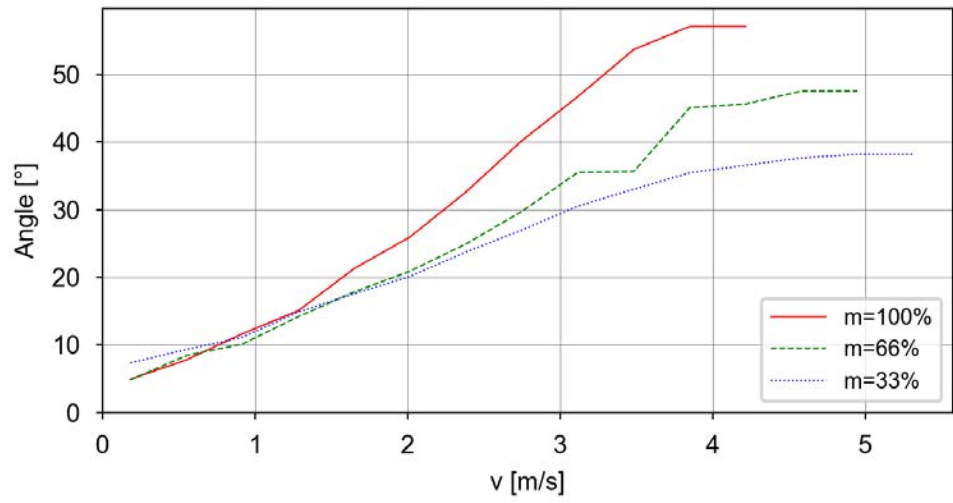

Continues on next page

## 2 Technical data for IRB 5710

### 2.11.8 IRB 5710-90/2.3 LID Inv

Continued

#### Category 1, Axis 3, Extension zone 0, stopping distance and stopping time

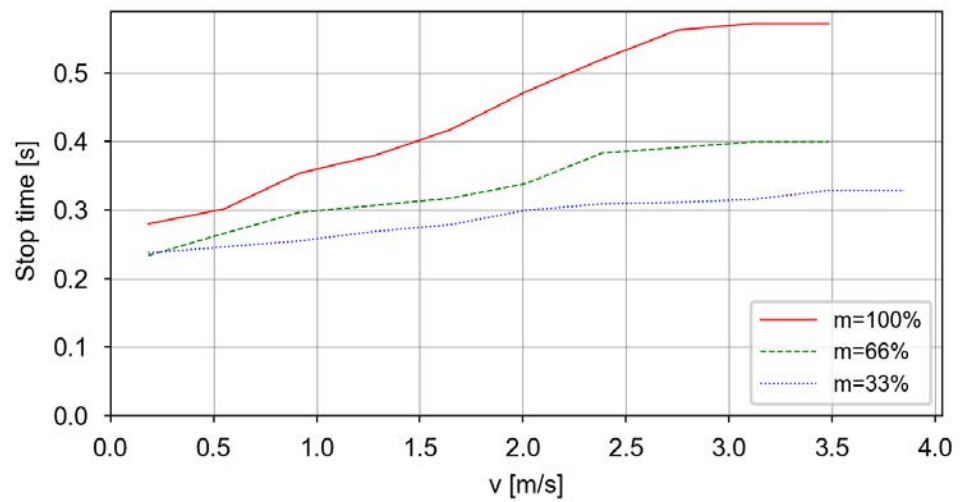
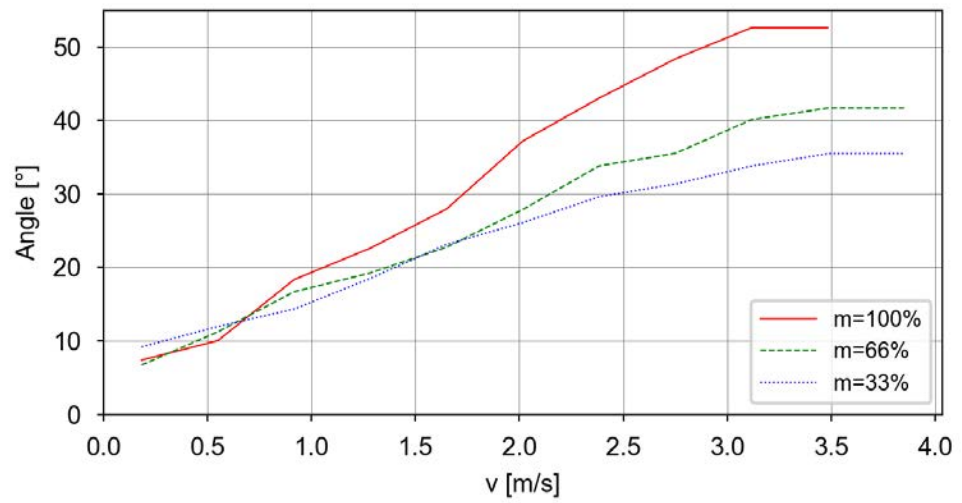



## 2.11.9 IRB 5710-70/2.7 LID

### Used tooldata

```
PERS tooldata P100:= [ TRUE, [[0, 0, 0], [1, 0, 0, 0]], [70, [0,
0, 200], [1, 0, 0, 0], 0.47, 0.47, 0.47]];
PERS tooldata P66:= [ TRUE, [[0, 0, 0], [1, 0, 0, 0]], [47, [0, 0,
133], [1, 0, 0, 0], 0.21, 0.21, 0.21]];
PERS tooldata P33:= [ TRUE, [[0, 0, 0], [1, 0, 0, 0]], [23, [0, 0,
67], [1, 0, 0, 0], 0.052, 0.052, 0.052]];

```

### Category 0

The following table describes the stopping distance and time for category 0 stop.

Axis	Distance	Stop time
1	45.9°	0.54 s
2	28.0°	0.36 s
3	30.1°	0.34 s

### Category 1, extension zones

For definitions of the zones, see [Extension zones on page 84](#).

The zone border is the mounting interface location for axis 2 and axis 3.

#### Axis 1

Zone border	Axis 2	Axis 3
z0-z1	-42°	42°
z1-z2	6°	-6°

#### Axis 2

Zone border	Axis 2	Axis 3
z0-z1	48°	30°
z1-z2	90°	-30°

#### Axis 3

Only one zone exists.

*Continues on next page*

## 2 Technical data for IRB 5710

### 2.11.9 IRB 5710-70/2.7 LID

Continued

#### Category 1, Axis 1, Extension zone 0, stopping distance and stopping time

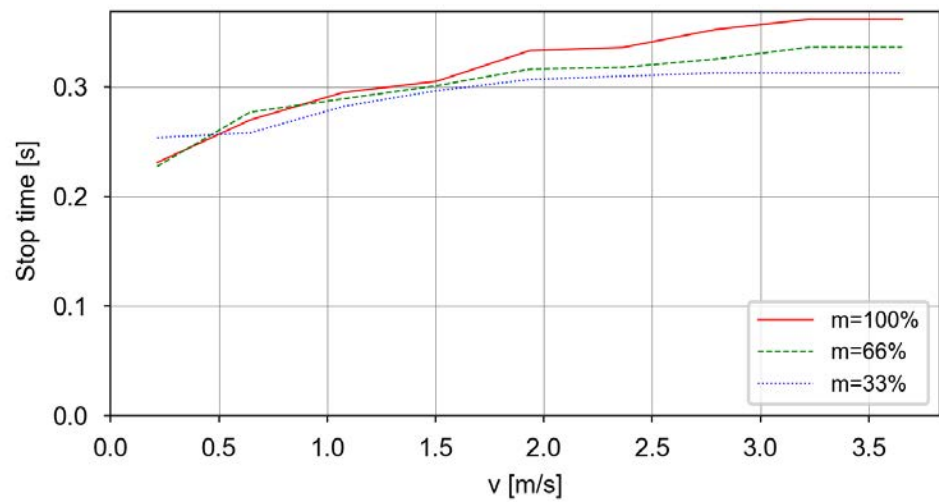
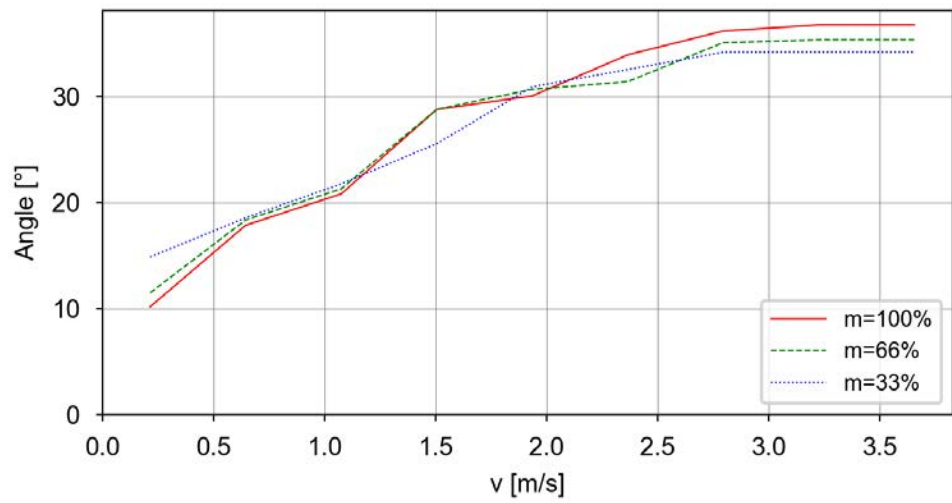

Continues on next page

Category 1, Axis 1, Extension zone 1, stopping distance and stopping time

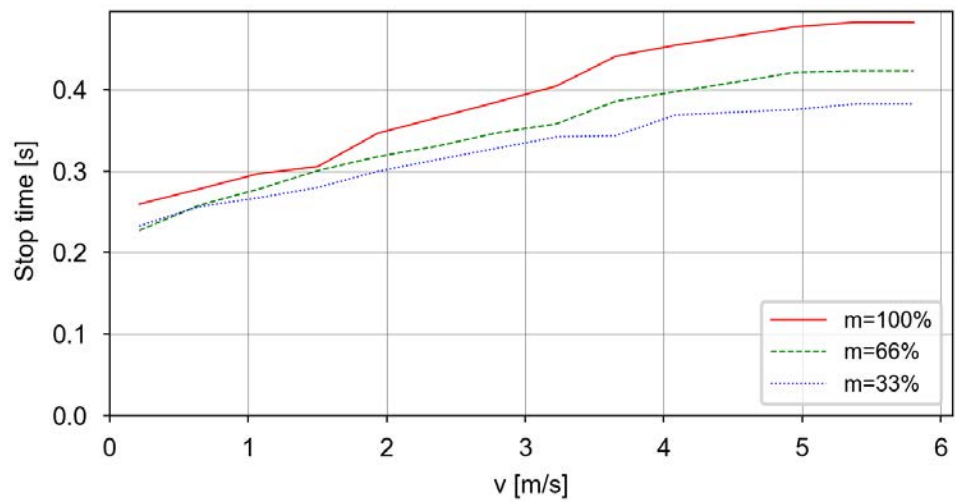
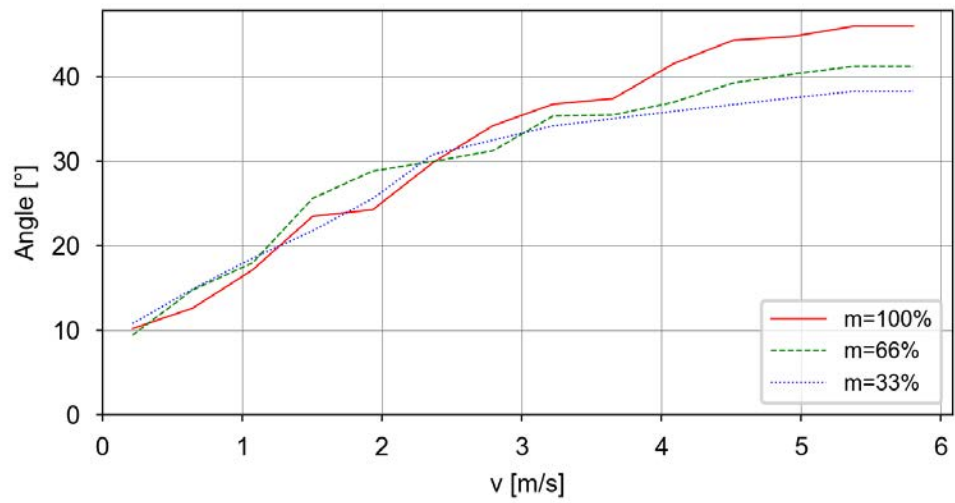

Continues on next page

## 2 Technical data for IRB 5710

### 2.11.9 IRB 5710-70/2.7 LID

Continued

#### Category 1, Axis 1, Extension zone 2, stopping distance and stopping time

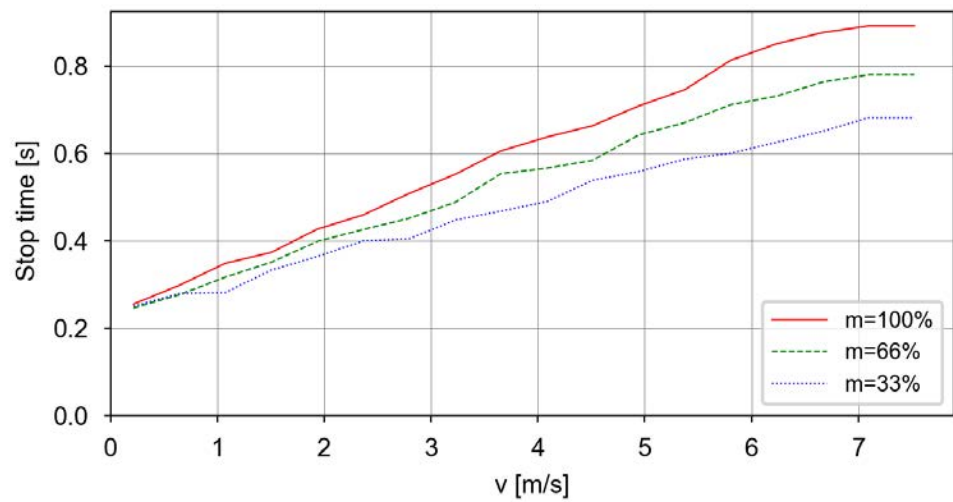
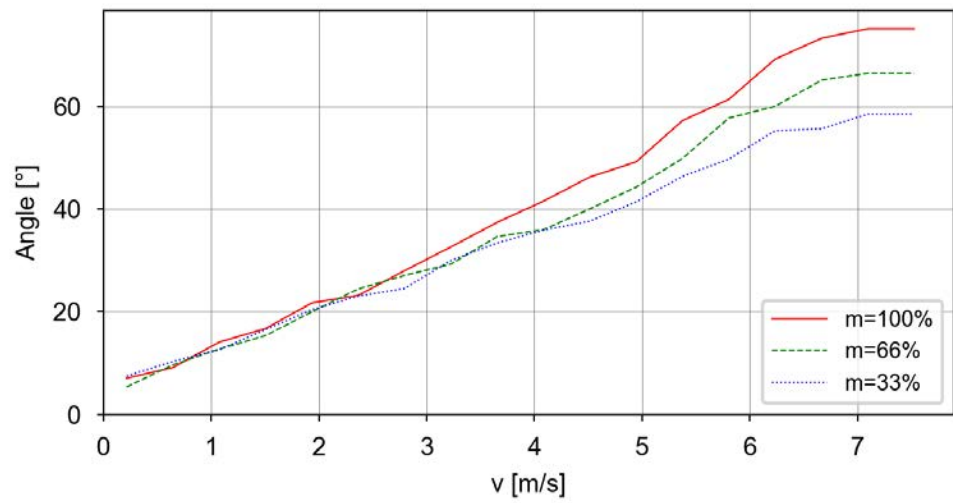

Continues on next page

Category 1, Axis 2, Extension zone 0, stopping distance and stopping time

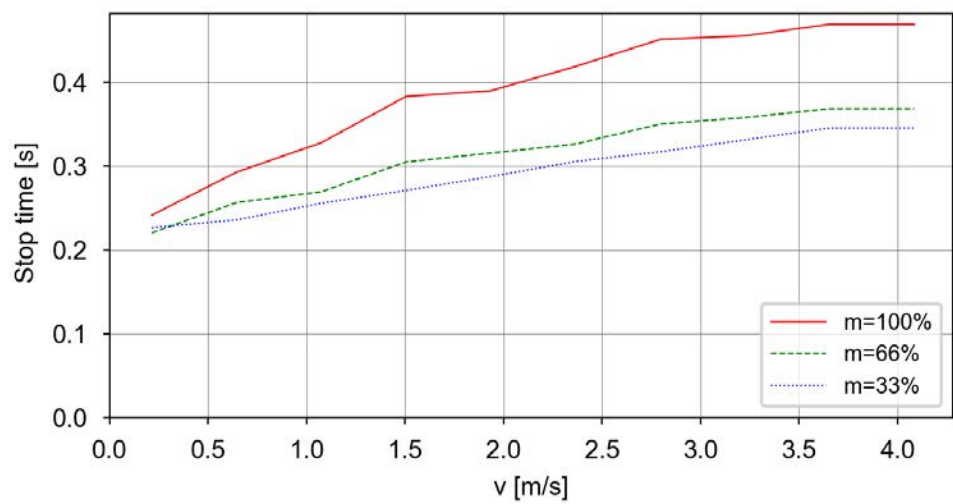
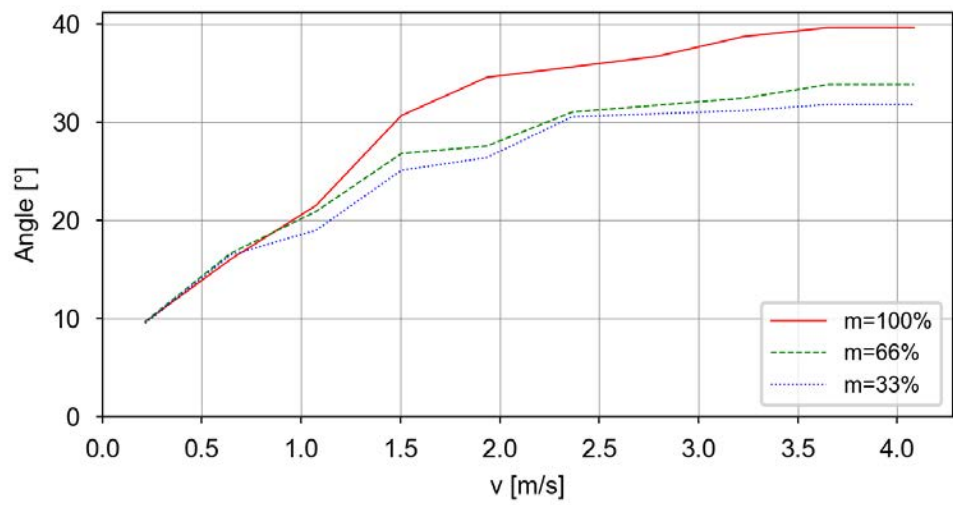

Continues on next page

## 2 Technical data for IRB 5710

### 2.11.9 IRB 5710-70/2.7 LID

Continued

#### Category 1, Axis 2, Extension zone 1, stopping distance and stopping time

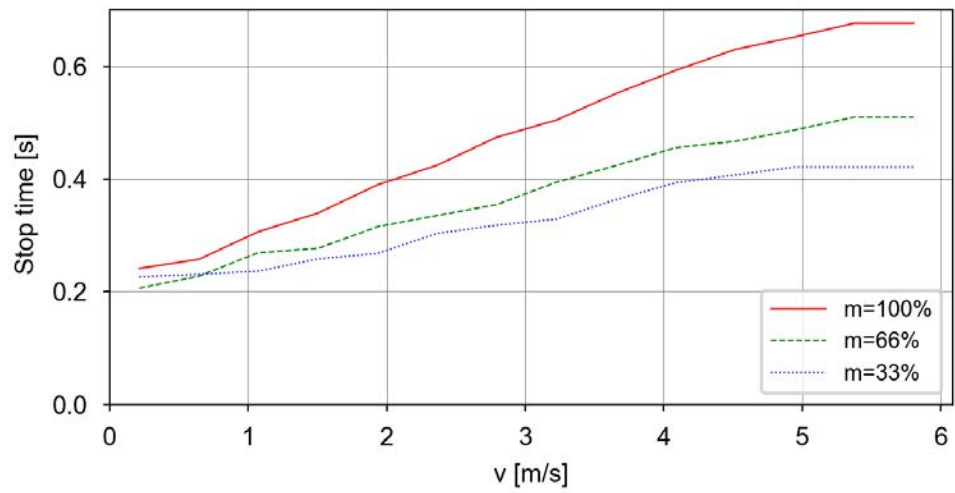
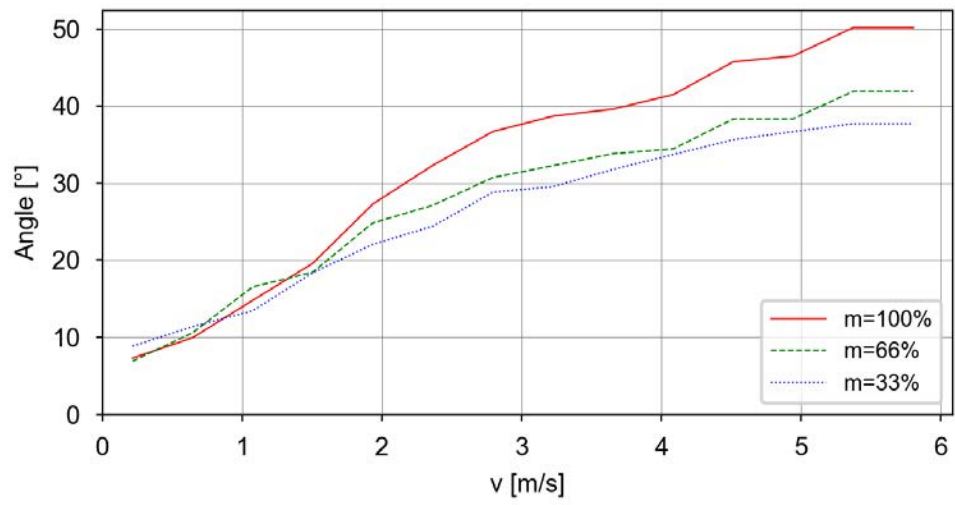

Continues on next page

Category 1, Axis 2, Extension zone 2, stopping distance and stopping time

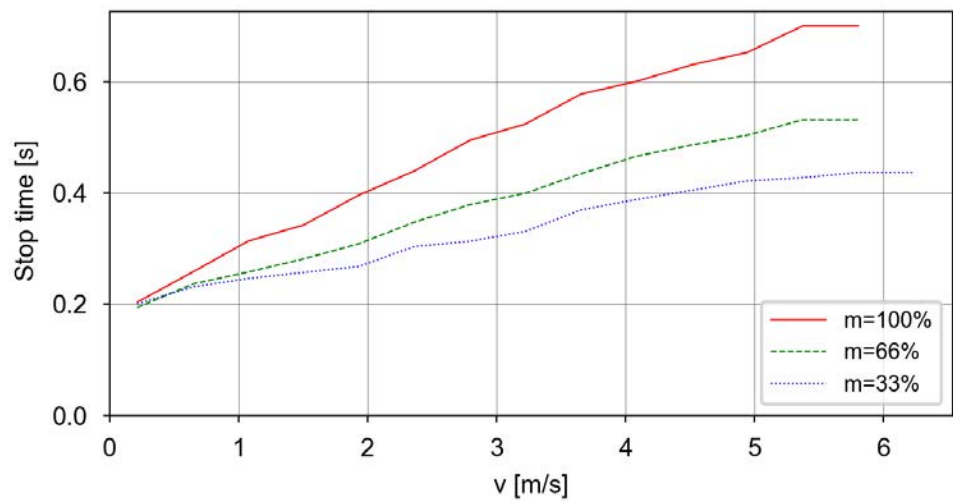
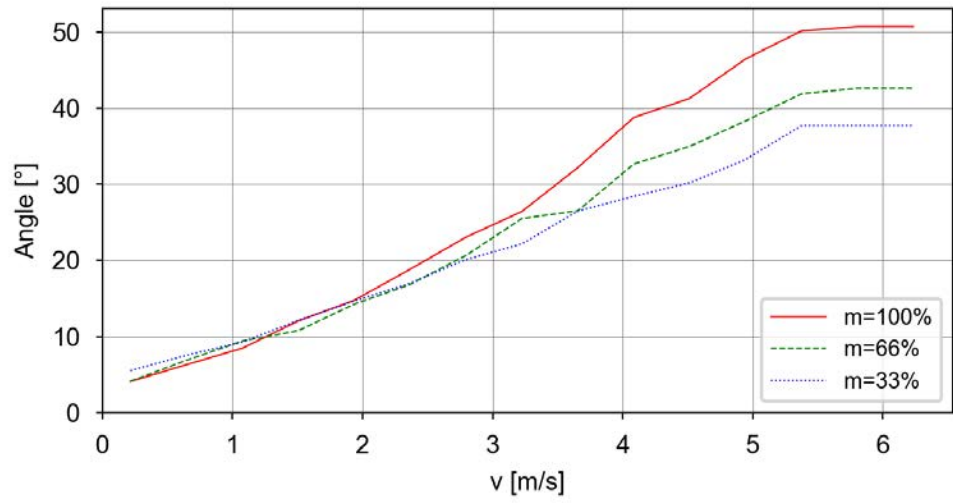

Continues on next page

## 2 Technical data for IRB 5710

### 2.11.9 IRB 5710-70/2.7 LID

Continued

#### Category 1, Axis 3, Extension zone 0, stopping distance and stopping time

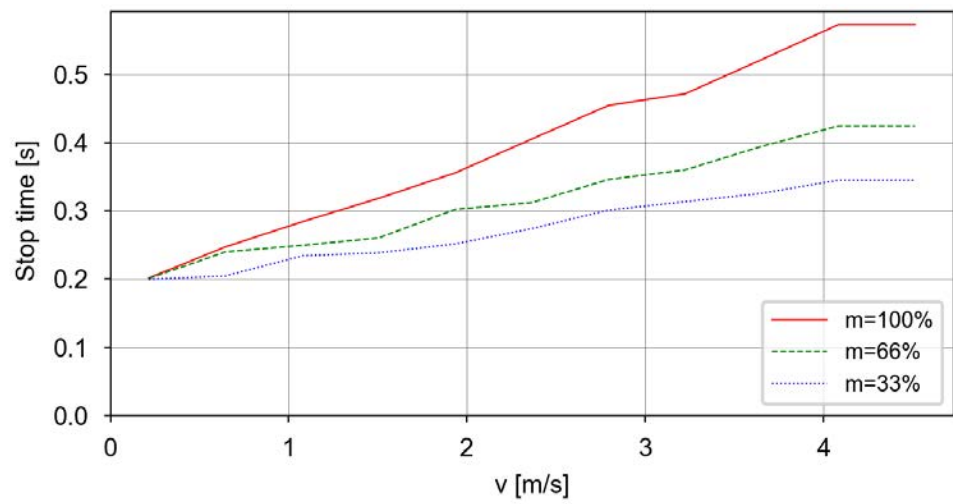
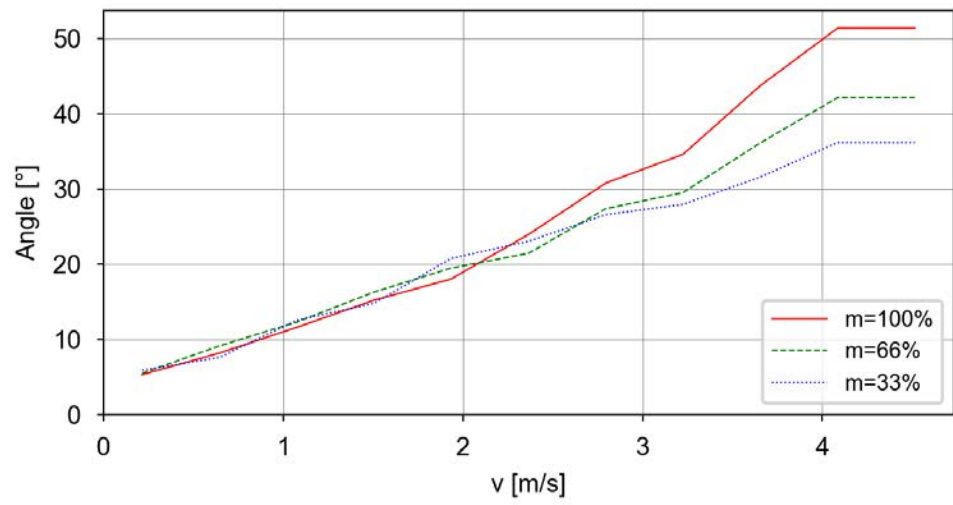



2.11.10 IRB 5710-70/2.7 LID Inv

Used tooldata

```
PERS tooldata P100:= [ TRUE, [[0, 0, 0], [1, 0, 0, 0]], [70, [0, 0, 200], [1, 0, 0, 0], 0.47, 0.47, 0.47]];
PERS tooldata P66:= [ TRUE, [[0, 0, 0], [1, 0, 0, 0]], [47, [0, 0, 133], [1, 0, 0, 0], 0.21, 0.21, 0.21]];
PERS tooldata P33:= [ TRUE, [[0, 0, 0], [1, 0, 0, 0]], [23, [0, 0, 67], [1, 0, 0, 0], 0.052, 0.052, 0.052]];
```

Category 0

The following table describes the stopping distance and time for category 0 stop.

Axis	Distance	Stop time
1	45.9°	0.54 s
2	26.8°	0.36 s
3	30.3°	0.34 s

Category 1, extension zones

For definitions of the zones, see [Extension zones on page 84](#).

The zone border is the mounting interface location for axis 2 and axis 3.

Axis 1

Zone border	Axis 2	Axis 3
z0-z1	-42°	42°
z1-z2	6°	-6°

Axis 2

Zone border	Axis 2	Axis 3
z0-z1	48°	30°
z1-z2	90°	-30°

Axis 3

Only one zone exists.

*Continues on next page*

## 2 Technical data for IRB 5710

### 2.11.10 IRB 5710-70/2.7 LID Inv

Continued

#### Category 1, Axis 1, Extension zone 0, stopping distance and stopping time

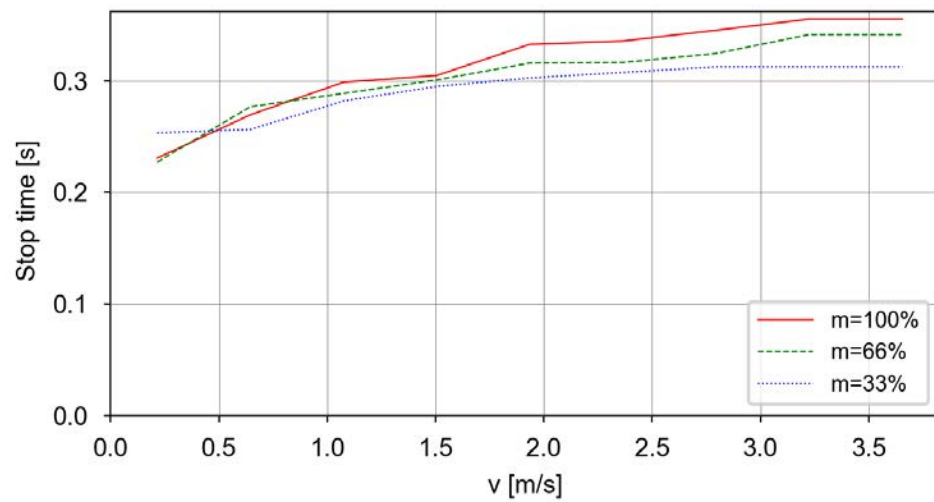
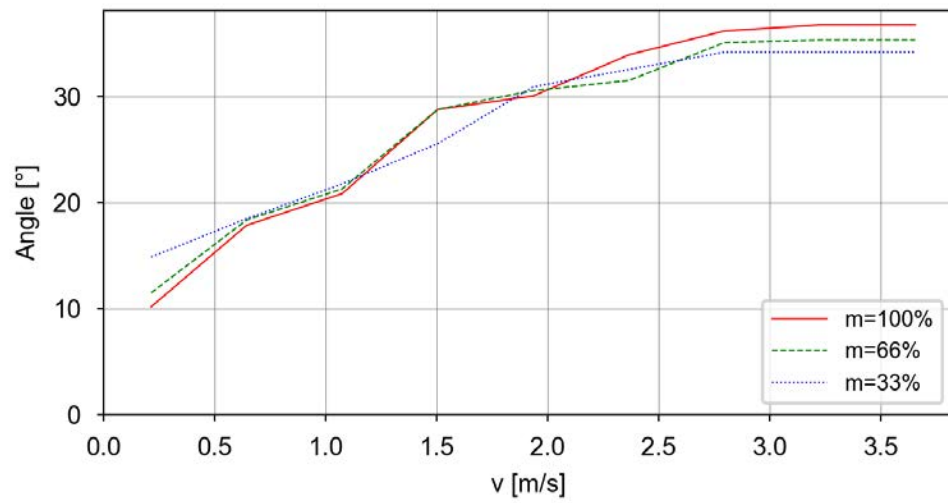

Continues on next page

Category 1, Axis 1, Extension zone 1, stopping distance and stopping time

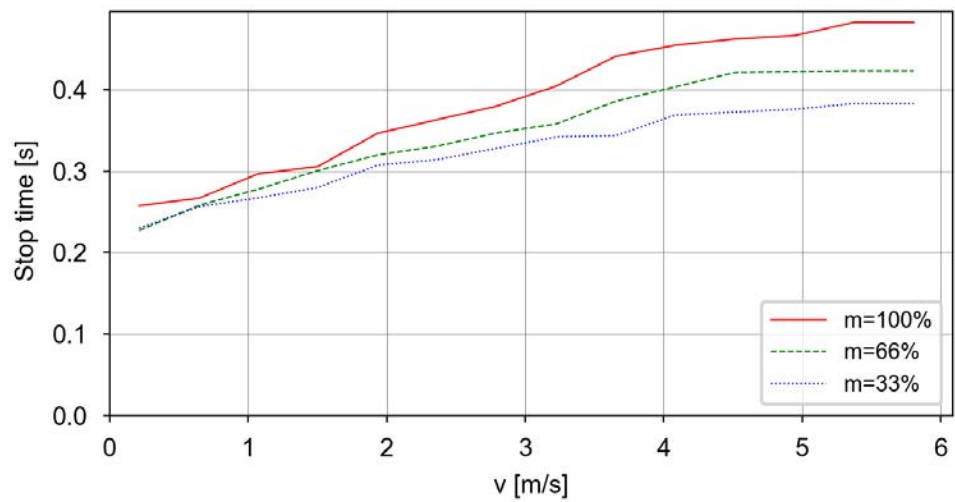
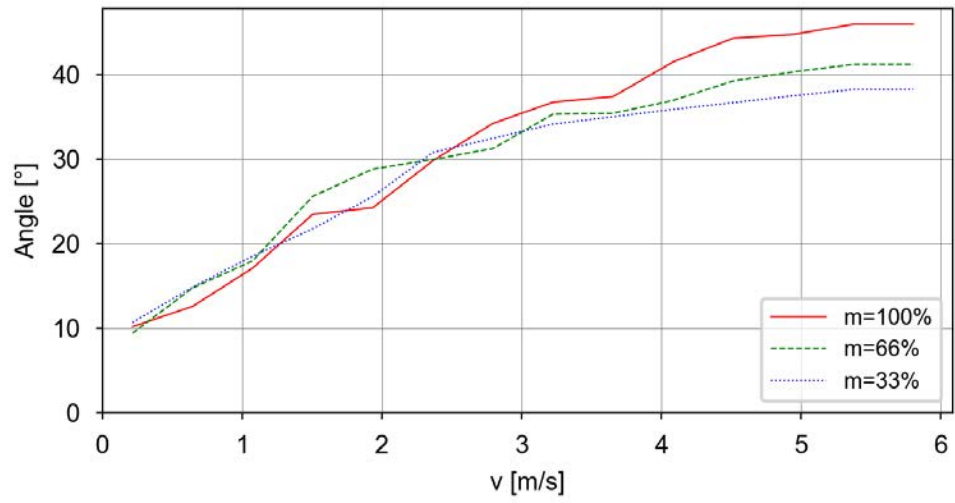

Continues on next page

## 2 Technical data for IRB 5710

### 2.11.10 IRB 5710-70/2.7 LID Inv

Continued

#### Category 1, Axis 1, Extension zone 2, stopping distance and stopping time

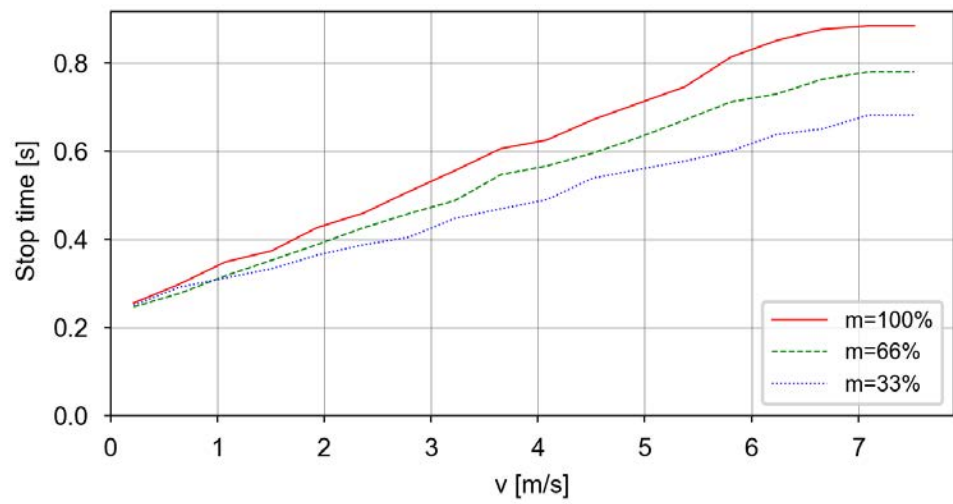
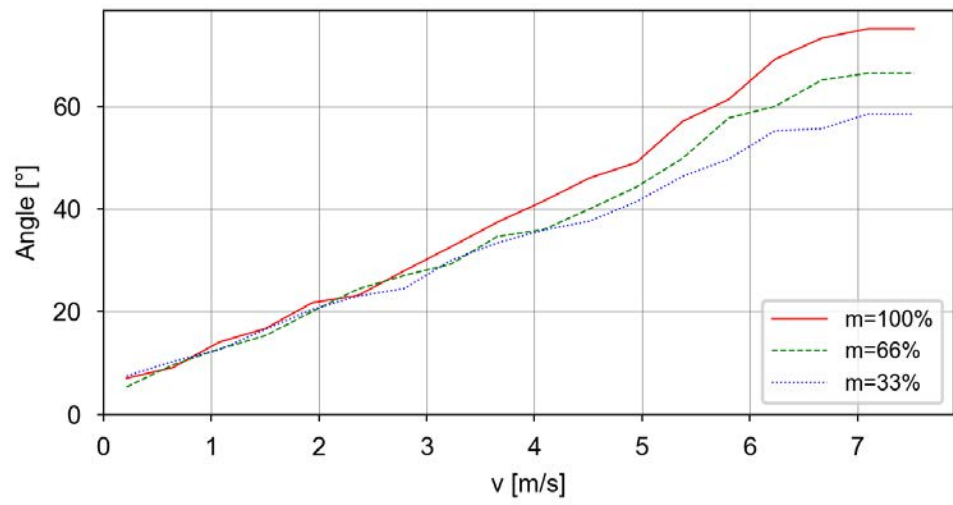

Continues on next page

Category 1, Axis 2, Extension zone 0, stopping distance and stopping time

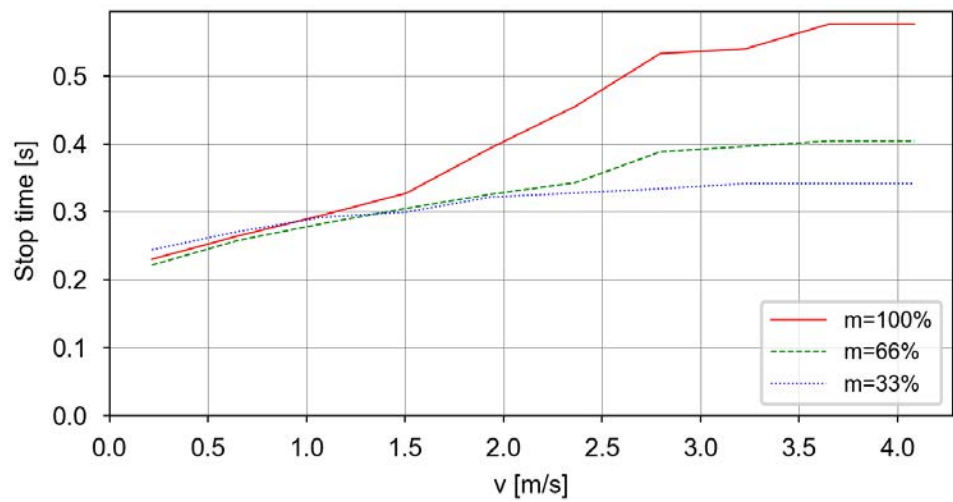
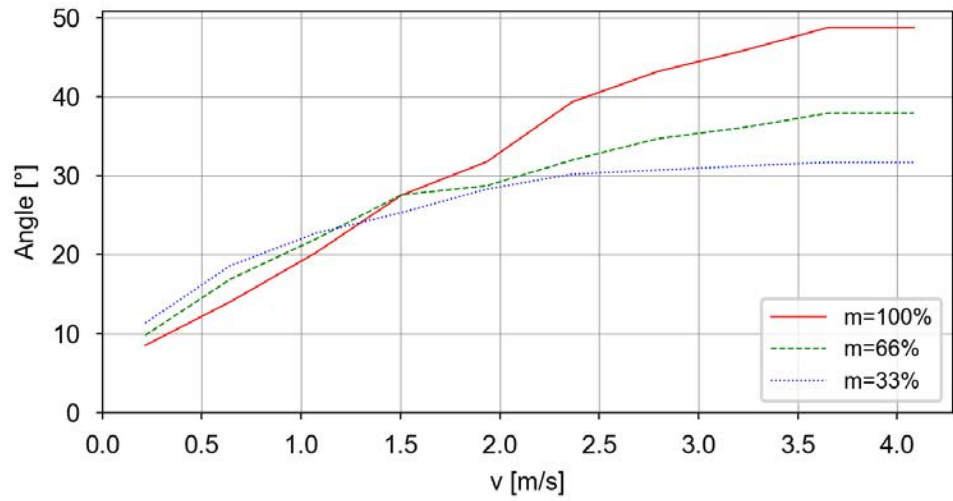

Continues on next page

## 2 Technical data for IRB 5710

### 2.11.10 IRB 5710-70/2.7 LID Inv

Continued

#### Category 1, Axis 2, Extension zone 1, stopping distance and stopping time

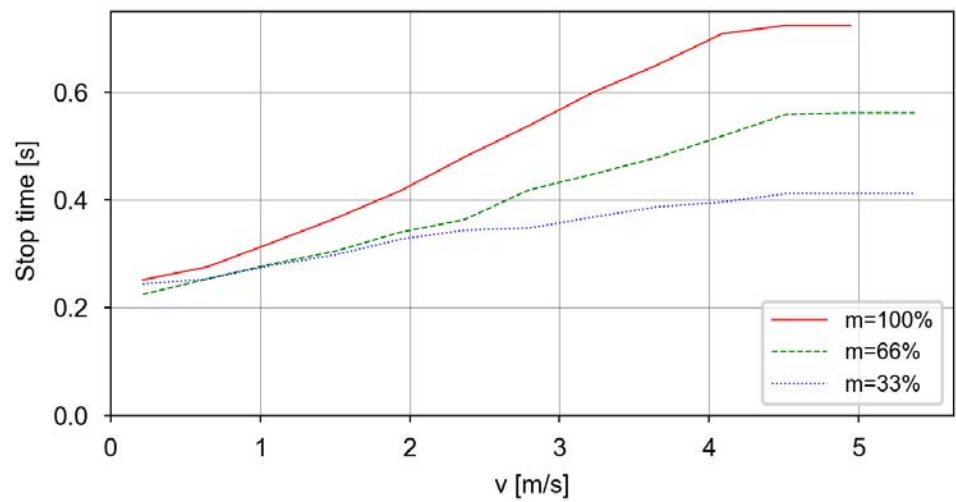
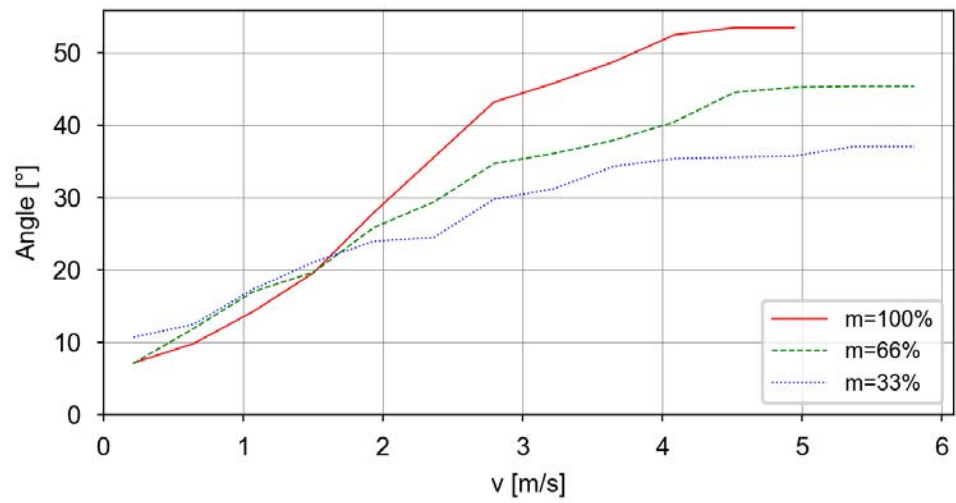

Continues on next page

Category 1, Axis 2, Extension zone 2, stopping distance and stopping time

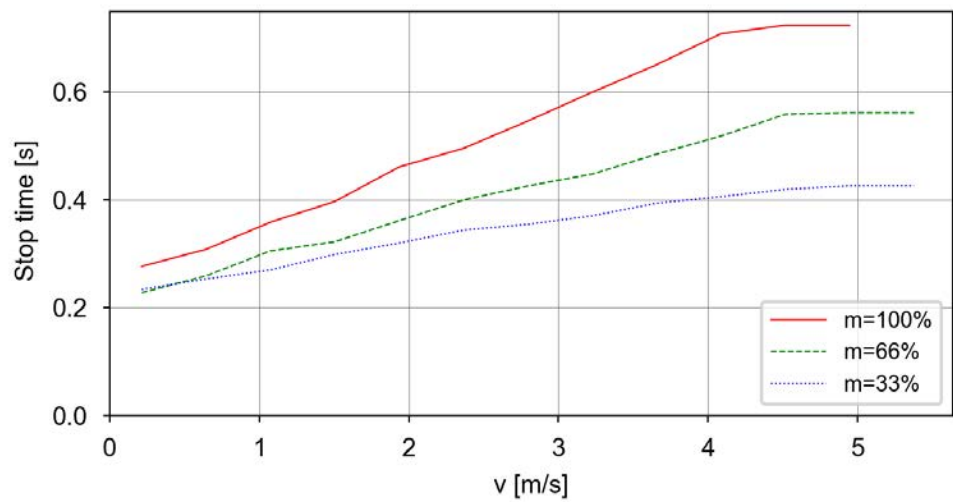
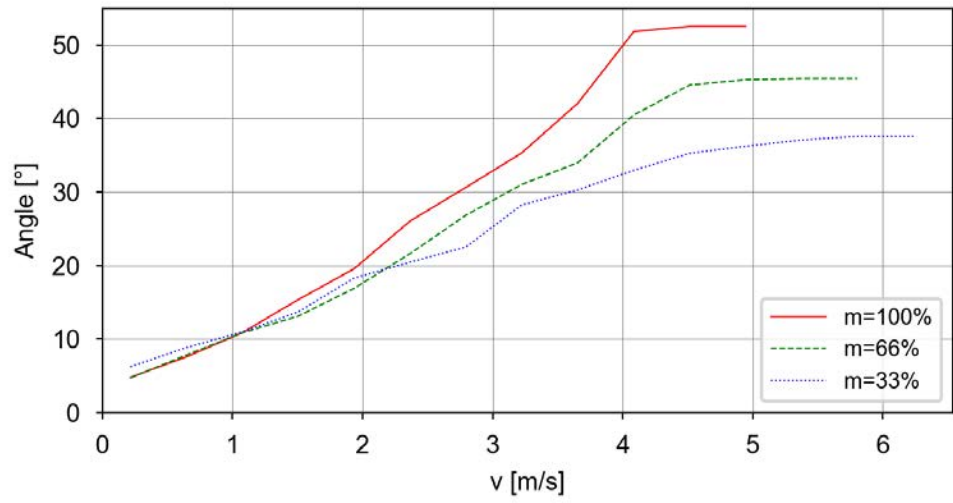

Continues on next page

## 2 Technical data for IRB 5710

### 2.11.10 IRB 5710-70/2.7 LID Inv

Continued

#### Category 1, Axis 3, Extension zone 0, stopping distance and stopping time

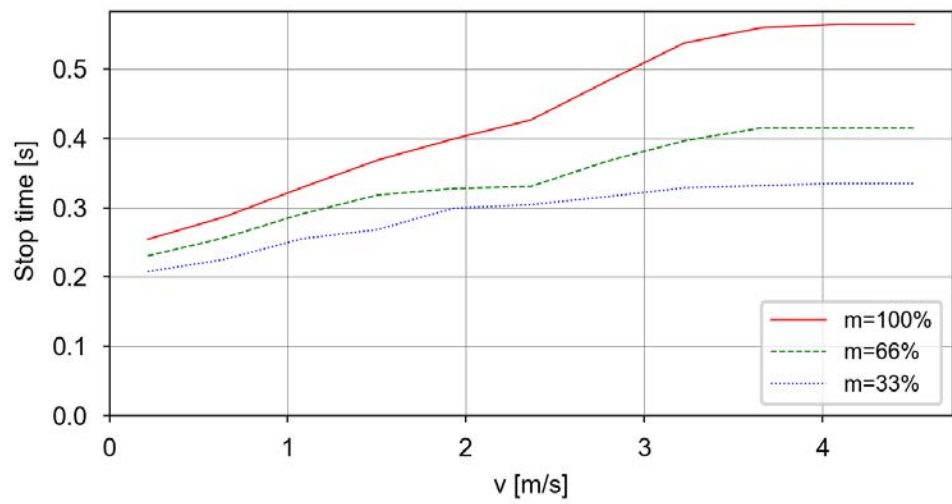
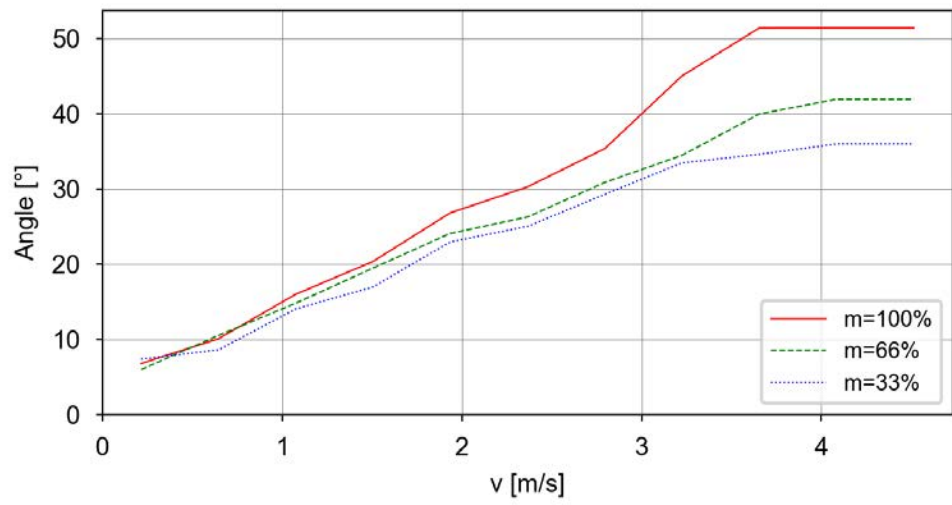



## 3 Specification of variants and options

### 3.1 Introduction to variants and options

---

#### General

The different variants and options for the IRB 5710 are described in the following sections. The same option numbers are used here as in the specification form.

The variants and options related to the robot controller are described in the product specification for the controller.

### 3 Specification of variants and options

#### 3.2 Manipulator

#### 3.2 Manipulator

##### Variants

Option number	IRB Type	Handling capacity (kg)	Reach (m)	Remark
3300-322	5710	110 kg	2.30 m	
3300-323	5710	90 kg	2.70 m	
3300-324 <sup>i</sup>	5710	90 kg	2.30 m	LID (LeanID)
3300-325 <sup>i</sup>	5710	70 kg	2.70 m	LID (LeanID)

<sup>i</sup> The options 3300-324 and 3300-325 require option DressPack axis 3-6 [3326-x]

##### Color options

For our robots, Graphite White is the standard default color, option 209-202. Colors according to the RAL color system are available.



xx2300001753



xx2300001752

Option	Color	RAL code <sup>i</sup>
209-202	ABB Graphite White std Standard color with protection option 3350-670 Base 67	RAL 7035
209-1	ABB orange standard Standard color with protection option 3352-10 Foundry Plus2 67	NCS 2070-Y60R
209 <sup>ii</sup>	RAL code should be specified (ABB non-standard colors)	

<sup>i</sup> The colors can differ depending on supplier and the material on which the paint is applied.

<sup>ii</sup> Only for robots with protection type *Base 67*.



##### Note

The colors stated in the table above are valid for manipulators. The accessories and spare parts are normally available in the standard color.

The orange color is recommended for foundry applications or other extra tough environments where there is a risk of color changes over time. This is not affecting the function, only the visual impression.

Continues on next page



**Note**

The delivery time for painted spare parts is longer for non-standard colors.

**Manipulator protection**

The manipulator is available with the following protection types.

Option	Description	Note
3350-670	Base 67	IP67
3352-10	Foundry Plus2 67	IP67

The basic design (IP67) is well prepared for normal or tough environment. This includes electrical design following the IP67 standard, and stainless steel screw used for all add-on parts after painting.

**Foundry Plus2 67**

For the extra tough environment, for example foundry industries, the option *Foundry Plus2 67* is recommended as protection type. It adds extra cable protection, extra sealings, protection plugs in unused holes, added rust preventive, and special paint/surface treatment, compared to protection type *Base 67*.

The below picture shows additional parts when choosing *Foundry Plus2 67*.

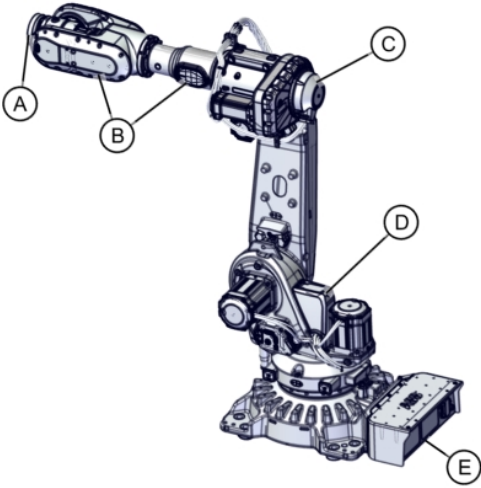
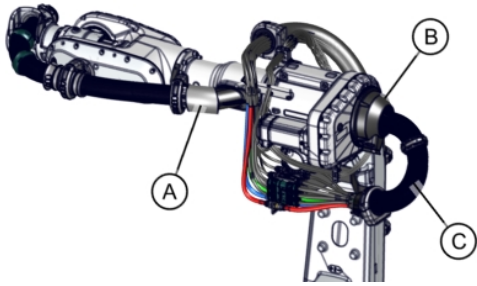
Additional parts for manipulator	Additional parts for DressPack
 <p>xx2300001751</p> <ul style="list-style-type: none"> <li>A Turning disc with Nickel-phosphorus coating</li> <li>B Rubber gasket</li> <li>C Protective cover</li> <li>D Protective cover</li> <li>E Sheet metal in stainless steel</li> </ul>	 <p>xx2300001750</p> <ul style="list-style-type: none"> <li>A Cable inlet</li> <li>B Protective cover</li> <li>C Cable protection</li> </ul>

**Requirements**

The option *Foundry Plus2* requires option *Upper arm cover* [3316-1].

Continues on next page

### 3 Specification of variants and options

#### 3.2 Manipulator

*Continued*

##### Foundry cable guard

Option	Description
3315-1	Foundry cable guard

The manipulator can be equipped with additional cable guards for extra tough environmental conditions, for example, metals spits or frequent weld spatter. These additional covers will prolong cable lifetime and simplify service/maintenance as the robot is kept more clean under the covers.

The option *Foundry Cable Guard* is recommended for *Foundry Plus2*.

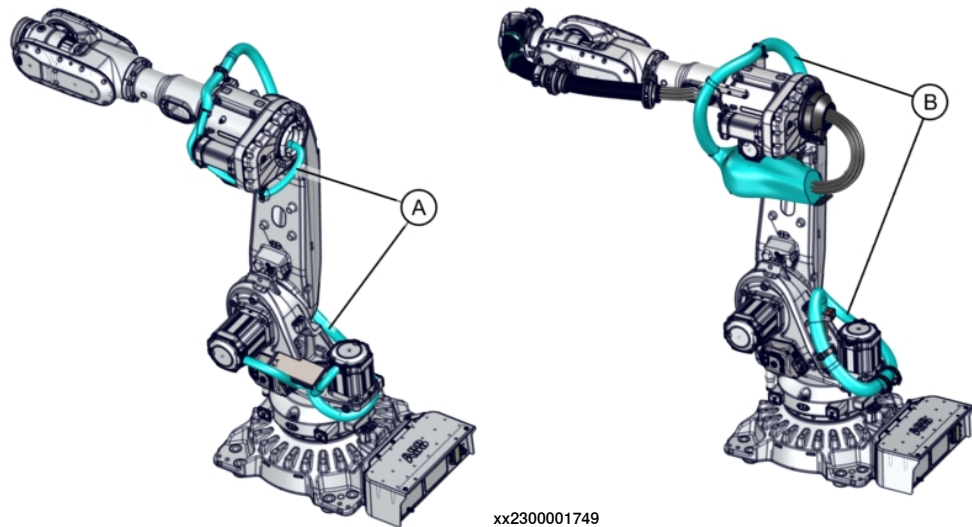

A	Foundry cable guard for manipulator cable harness
B	Foundry cable guard for DressPack

##### Requirements

The option *Foundry Cable Guard* requires option *Upper arm cover* [3316-1].

##### Upper arm cover

Option	Description
3316-1	Upper arm cover

The manipulator can be equipped with additional upper arm covers for environmental conditions, where you want to further seal off the upper arm in wet

*Continues on next page*

or dirty conditions. These additional covers will prolong the lifetime of the cables, and simplify service/maintenance as the robot is kept more clean under the covers.



xx2100002592

#### Requirements

This option is mandatory to order with the option *Foundry Plus2 [3352-10]*.

This option is mandatory to order with the option *Foundry Cable Guard [3315-1]*.

This option is mandatory to order with the option *DressPack axis 3-6 [3326-x]*.

#### Mounting position

Option	Description
3317-1	Inverted

*Continues on next page*

### 3 Specification of variants and options

---

#### 3.2 Manipulator

*Continued*

The manipulator can be placed inverted to add more flexibility in layout design. The option is prepared for inverted assembly from factory.



xx2100002593

#### Limitations

This option is not possible to order with *AbsAcc Floor mounted* [3101-1].

*Continues on next page*

#### Forklift device

The manipulator can be delivered with forklift devices, allowing a forklift to be used when moving the manipulator.

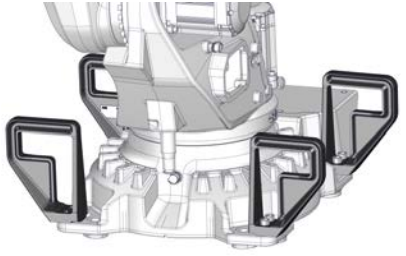
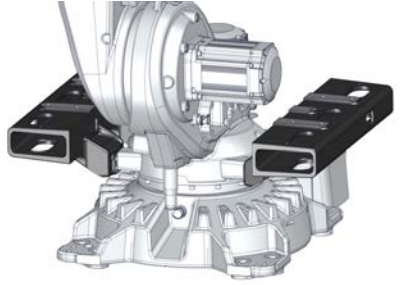
Option	Description	
3318-1	Forklift device on base Forklift pockets placed on the base gives a low lifting point.	 <p>xx2300001244</p>
3318-2	Forklift device on frame Fork lift pockets placed on the frame gives a more balanced lifting point. This can be used together with special tool to invert a robot.	 <p>xx2300001243</p>

#### Limitations

The option *Fork lift on base* [3318-1] cannot be combined with the option *Inverted* [3317-1].

#### Resolver connection 7th axis

Option	Description
3322-1	On base
3322-2	In servo DressPack Requires options for DressPack base-axis 3.

#### Limited working range

Option	Description
3323-1	Axis 1 adjustable 15°

The manipulator can be equipped with adjustable mechanical stops. This is to mechanically limit the working range on axis 1. The mechanical stops are delivered alongside the robot (not installed). The stops can be placed in steps according to the option.

Continues on next page

### 3 Specification of variants and options

#### 3.2 Manipulator Continued

For detailed information see [Installing movable mechanical stops on axis 1 \(option 3323-1\) on page 54](#).

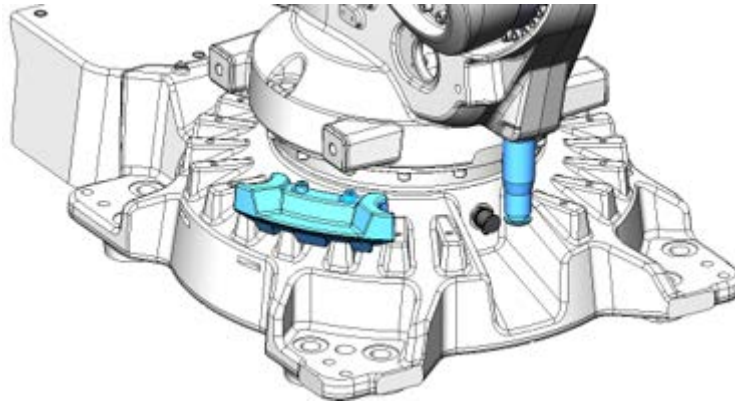

xx2100002595

#### Extended working range

Option	Description	
3324-1	Axis 1 to $\pm 220^\circ$	The option extends the working range on axis 1 from $\pm 170^\circ$ to $\pm 220^\circ$ .



#### CAUTION

The option *Extended work range* enables an extension of the working range for axis 1, through a software configuration. With this option installed, the working range can exceed the range limited by the mechanical stop on axis 1. The working range shall be limited through the option *SafeMove*.

A risk analysis must be done to ensure that no risks remain when using option *Extended work range*, to limit the working range, and before removing the mechanical stops.

For information about the option *SafeMove*, see *Application manual - Functional safety and SafeMove*.

If the mechanical stop is removed, then the manipulator should have a marking for this, for example, a label. If the robot is delivered with the option *Extended work range*, then such a label is included on delivery.

#### Limitations

This option is not possible to order with the option *Inverted* [3317-1].

#### Requirements

This option requires the option *SafeMove* [3043-x].



3.3 Floor cables

Manipulator cable - Length

Option	Description
3200-2	7 m
3200-3	15 m
3200-4	22 m
3200-5	30 m

Bending radius for static floor cables

The minimum bending radius is 10 times the cable diameter for static floor cables.

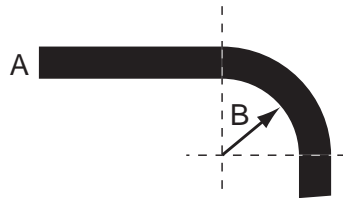

xx1600002016

A	Diameter
B	Diameter x10

## 3 Specification of variants and options

---

### 3.4.1 Overview of DressPack options

## 3.4 Application

### 3.4.1 Overview of DressPack options

---

#### General

The DressPack is built in sections with connection interfaces in between. The cables for customer connection are partly integrated in the robot and the connectors are placed at axis 6, axis 3, and at the base. Depending on what signals are required, there are different variants available (Parallel, EtherNet, CC link) with corresponding connections at axis 6, axis 3, and at the base interface.

Parallel	PROC1 (1/2" Hose for compressed air) & CP/CS Hose (1/2") for compressed air is included in all DressPack variants. There is one inlet at the base (M22x1.5), one outlet at axis 3 (M22x1.5), and a free end at axis 6.
EtherNet	PROC1, CP/CS, EtherNet & FE (functional earth)
CC link	PROC1, CP/CS, EtherNet & FE (functional earth)

#### Requirements

Upper arm DressPack requires lower arm DressPack.

LID manipulator variants can only use LID DressPack.

LID manipulator variants require both lower and upper arm DressPack.

### 3.4.2 DressPack for material handling

#### Connection interfaces

Below is an overview showing the DressPack connection points. For detailed information see *Circuit diagram - IRB 5710/IRB 5720*, listed in [References on page 7](#).

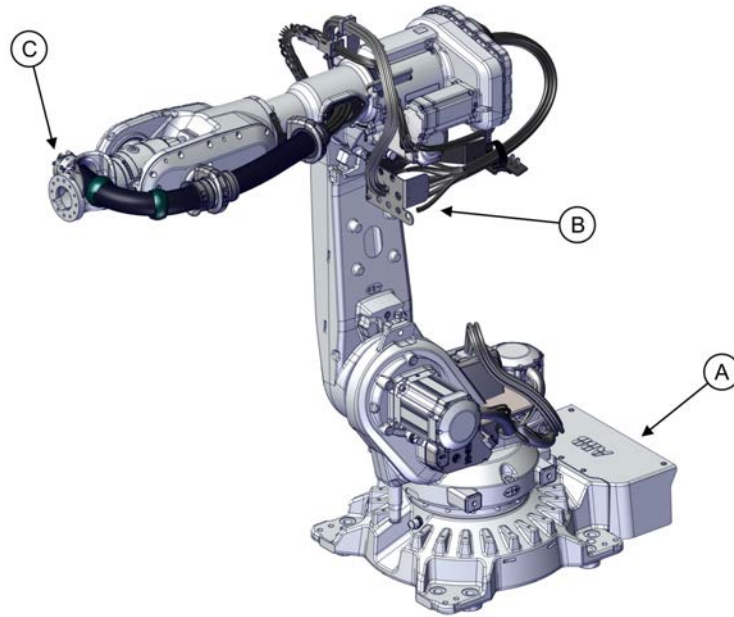

xx2300001382

A	Base
B	Axis 3
C	Axis 6

#### Manipulator DressPack MH

Base to axis 3	Axis 3 to axis 6
3325-11	3326-11 MH3 Parallel
	3326-30 MH LID empty conduit
	3326-31 MH LID Parallel
3325-13	3326-13 MH3 EtherNet
	3326-30 MH LID empty conduit
	3326-33 MH LID EtherNet
3325-14	3326-14 MH3 CC-Link
	3326-30 MH LID empty conduit
	3326-34 MH LID CC-Link

*Continues on next page*

### 3 Specification of variants and options

#### 3.4.2 DressPack for material handling

Continued

#### DressPack MH base to axis 3

Option	Description	Note	Connectors
3325-11	MH Parallel	Lower arm MH	Customer power (CP), customer signal (CS), and PROC1
3325-13	MH EtherNet	Lower arm MH Includes parallel signals. Supports ProfiNet, EtherNet/IP.	Customer power (CP), customer signal (CS), ETHERNET, PROC1, and functional earth (FE)
3326-14	MH CC-Link	Lower arm MH Includes parallel signals.	Customer power (CP), customer signal (CS), ETHERNET, PROC1, and functional earth (FE)

#### Connection plate at base for DressPack MH

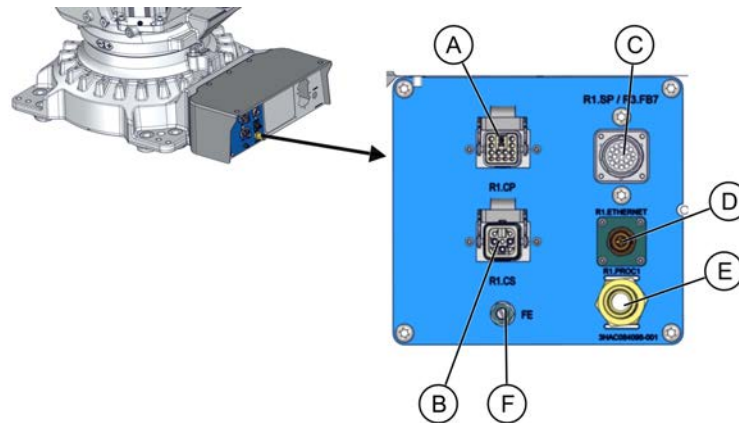

xx2300000241

A	Customer power (CP)
B	Customer signal (CS)
C	Servo Power (SP)
D	ETHERNET
E	PROC1 (1/2" hose)
F	Functional earth (FE)

For corresponding parts of the tool, see [Connector kits manipulator on page 175](#).

Continues on next page

### 3 Specification of variants and options

#### 3.4.2 DressPack for material handling Continued

Connection plate at axis 3 for DressPack MH, MH3 and LeanID MH

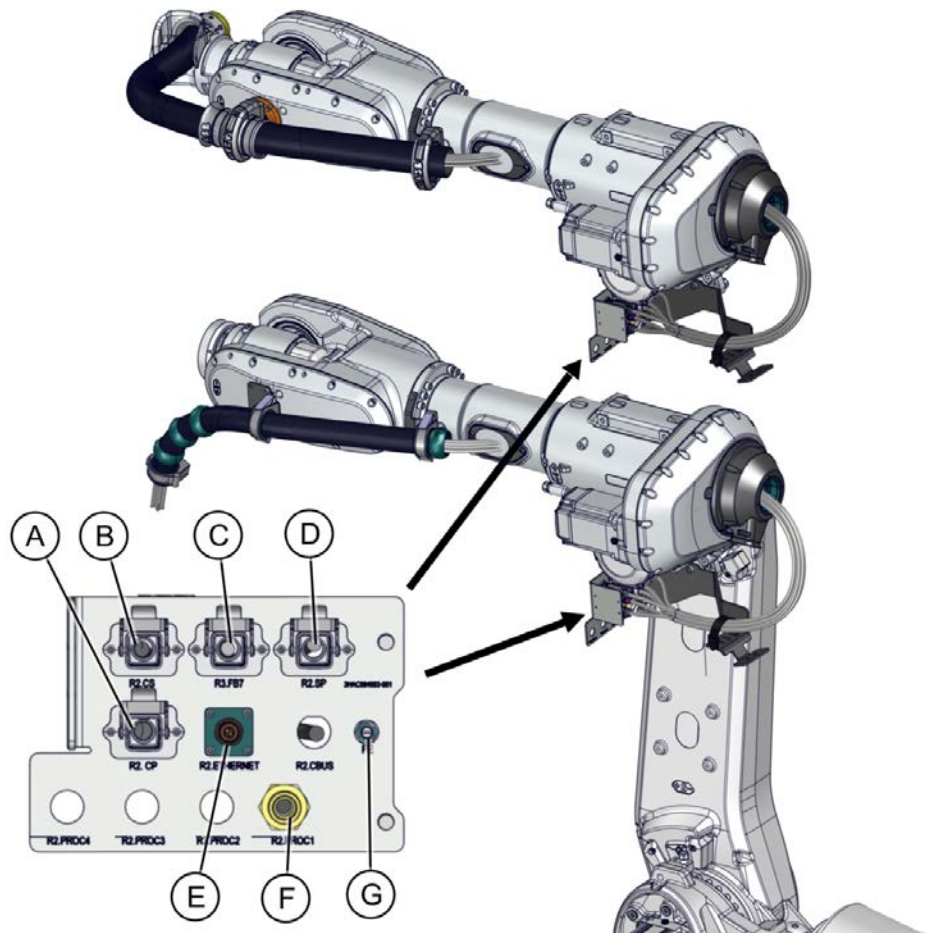

xx2300000246

A	Customer power (CP)
B	Customer signal (CS)
C	Servo feedback (FB)
D	Servo power (SP)
E	ETHERNET
F	PROC 1 (1/2" hose)
G	Functional earth (FE)

For corresponding parts of the tool, see [Connector kits manipulator on page 175](#).

#### DressPack axis 3 to axis 6

Option	Description	Note	Connectors
3326-11	MH3 Parallel	Upper arm MH3	Customer power (CP), customer signal (CS), and PROC1

Continues on next page

### 3 Specification of variants and options

#### 3.4.2 DressPack for material handling

*Continued*

Option	Description	Note	Connectors
3326-13	MH3 EtherNet	Upper arm MH3 Includes parallel signals. Supports ProfiNet, Ether- tIP.	Customer power (CP), customer signal (CS), ETHERNET, PROC1, and functional earth (FE)
3326-14	MH3 CC-Link	Upper arm MH3 Includes parallel signals.	Customer power (CP), customer signal (CS), ETHERNET, PROC1, and functional earth (FE)
3326-30	MH LID Empty Con- duit	LeanID	
3326-31	MH LID Parallel	LeanID MH	Customer power (CP), customer signal (CS), and PROC1
3326-33	MH LID EtherNet	LeanID MH Includes parallel signals. Supports ProfiNet, Ether- tIP.	Customer power (CP), customer signal (CS), ETHERNET, PROC1, and functional earth (FE)
3326-34	MH LID CC-Link	LeanID MH Includes parallel signals.	Customer power (CP), customer signal (CS), ETHERNET, PROC1, and functional earth (FE)

End connectors at axis 6 for DressPack MH3 and LeanID MH

MH3: Hose and cable free length, 1,000 mm

*Continues on next page*

### 3 Specification of variants and options

#### 3.4.2 DressPack for material handling

*Continued*

LID: Hose and cable free length, 1,000 mm

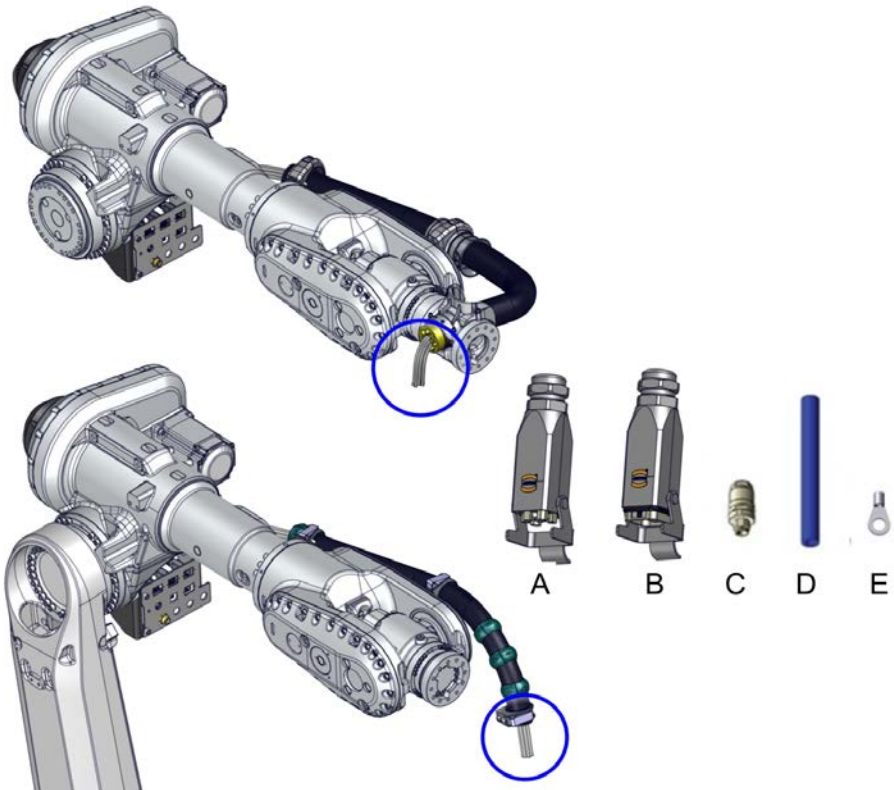

xx2300000247

A	Customer power (CP)
B	Customer signal (CS)
C	ETHERNET
D	PROC 1 (1/2" hose)
E	FE (functional earth)

For corresponding parts of the tool, see [Connector kits manipulator on page 175](#).

### 3 Specification of variants and options

#### 3.4.3 DressPack for spotwelding

#### 3.4.3 DressPack for spotwelding

##### Connection interfaces

Below is an overview showing the DressPack connection points. For detailed information see *Circuit diagram - IRB 5710/IRB 5720*, listed in [References on page 7](#).

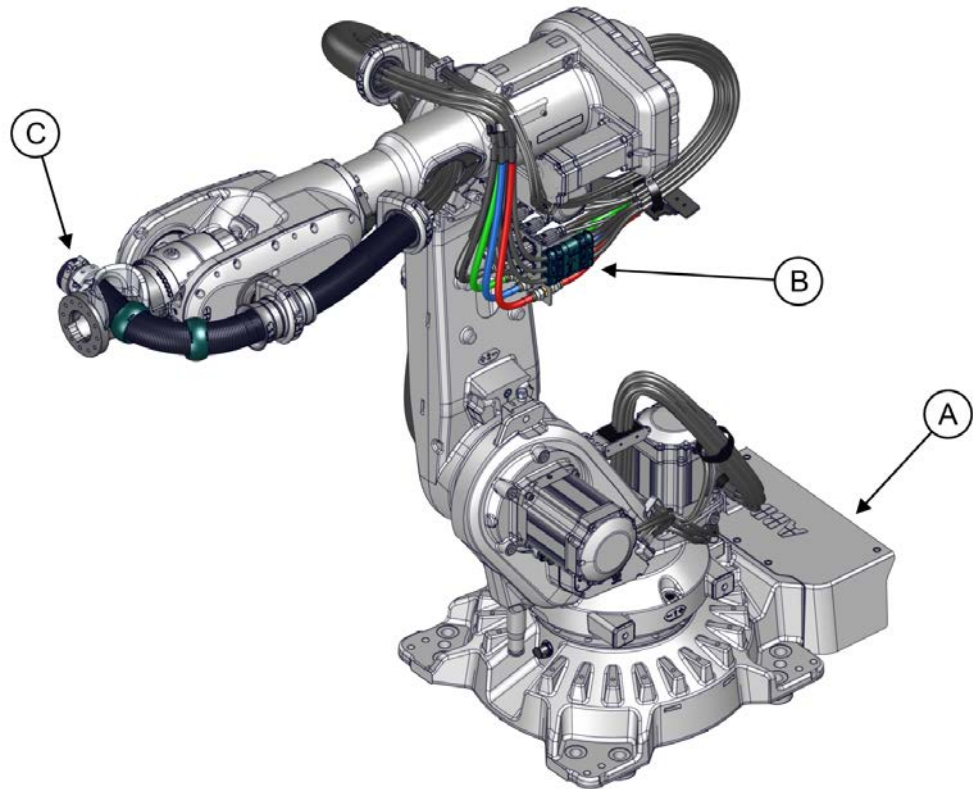

xx2300001381

A	Base
B	Axis 3
C	Axis 6

##### Manipulator DressPack SW

Base to axis 3	Axis 3 to axis 6
3325-61	3326-61 SW LID Parallel-Servo
	3326-50 SW LID Empty Conduit
3325-63	3326-63 SW LID EtherNet-Servo
	3326-50 SW LID Empty Conduit
3326-64	3326-64 SW LID CC Link-Servo
	3326-50 SW LID Empty Conduit

*Continues on next page*



### 3 Specification of variants and options

#### 3.4.3 DressPack for spotwelding Continued

#### DressPack SW base to axis 3

Option	Description	Note	Connectors
3325-61	SW Parallel-Servo	Lower arm SW	Customer power (CP), customer signal (CS), Servo power (SP), Servo feedback (FB)
3325-63	SW Ethernet-Servo	Lower arm SW Includes parallel signals. Supports ProfiNet, Ether- tIP	Customer power (CP), customer signal (CS), Servo power (SP), Servo feedback (FB)
3325-64	SW CC Link-Servo	Lower arm SW Includes parallel signals.	Customer power (CP), customer signal (CS), Servo power (SP), Servo feedback (FB)

#### Connection plate at base for DressPack SW

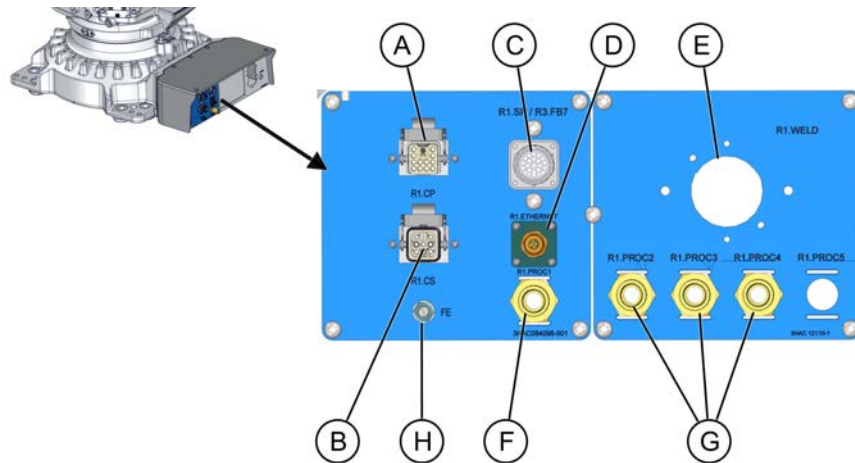

xx230000250

A	Customer power (CP)
B	Customer signal (CS)
C	Servo Power (SP)
D	ETHERNET
E	WELD3 x 35 mm <sup>2</sup> (spot welding)
F	PROC1 (1/2" hose, M22 x 1.5, 24 degree seal)
G	PROC2-4 (spot welding 1/2", M22 x 1.5, 24 degree seal)
H	Functional earth (FE)

For corresponding parts of the tool, see [Connector kits manipulator on page 175](#).

Continues on next page

### 3 Specification of variants and options

#### 3.4.3 DressPack for spotwelding

Continued

Connection plate at axis 3 for DressPack SW and LeanID SW

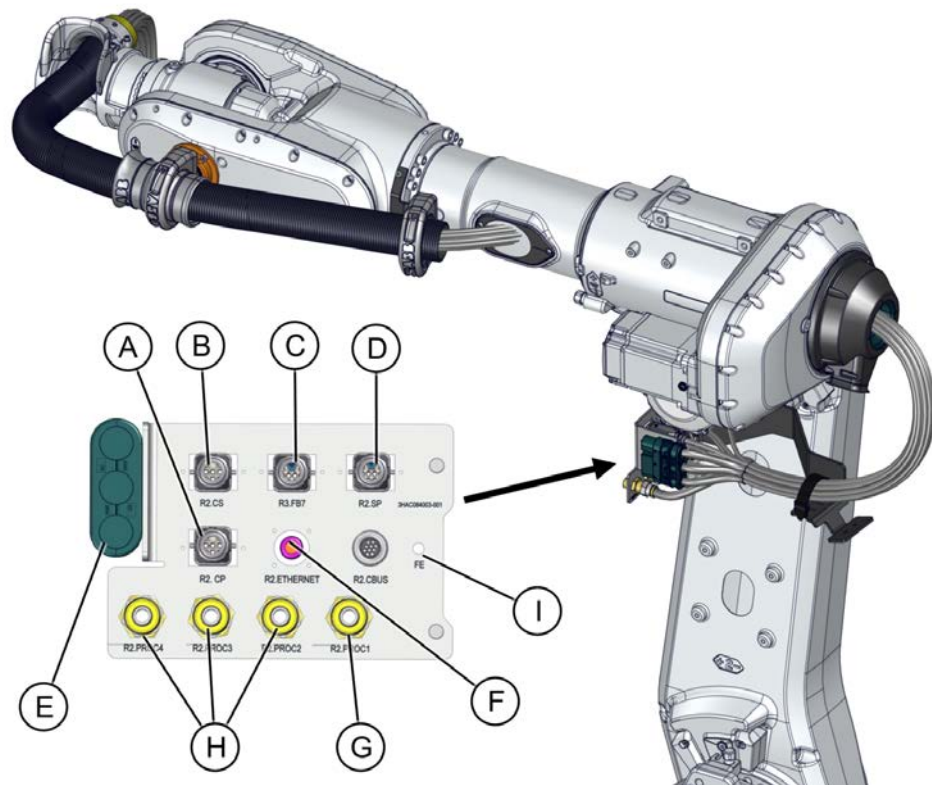

xx2300000251

A	Customer power (CP)
B	Customer signal (CS)
C	Servo feedback (FB)
D	Servo power (SP)
E	WELD3 x 25 mm <sup>2</sup> (spot welding)
F	ETHERNET
G	PROC1 (1/2" hose, M22 x 1.5, 24 degree seal)
H	PROC2-4 (spot welding 1/2", M22 x 1.5, 24 degree seal)
I	Functional earth (FE)

For corresponding parts of the tool, see [Connector kits manipulator on page 175](#).

#### DressPack axis 3 to axis 6

Option	Description	Note	Connectors
3326-50	SW LID Empty Conduit	Upper arm SW LID	
3326-61	SW LID Parallel-Servo	Upper arm SW LID	Customer power (CP), customer signal (CS)

Continues on next page

### 3 Specification of variants and options

#### 3.4.3 DressPack for spotwelding

*Continued*

Option	Description	Note	Connectors
3326-63	SW LID EtherNet-Servo	Upper arm SW LID Includes parallel signals. Supports ProfiNet, EtherNet/IP	Customer power (CP), customer signal (CS)
3326-64	SW LID CC Link-Servo	Upper arm SW LID Includes parallel signals.	Customer power (CP), customer signal (CS)

End connectors at axis 6 for DressPack LeanID SW

For corresponding parts of the tool, see [Connector kits manipulator on page 175](#).

### 3 Specification of variants and options

#### 3.4.4 Configuration result of DressPack options

#### 3.4.4 Configuration result of DressPack options

##### DressPack options for material handling (MH)

The DressPack contents will differ depending on selected options. See table for signal content below.

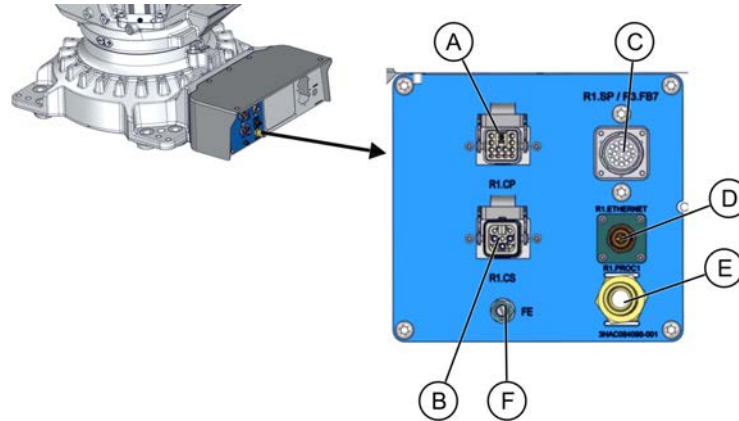

xx2300000241

A	Customer power (CP)
B	Customer signal (CS)
C	Servo Power (SP)
D	ETHERNET
E	PROC1 (1/2" hose)
F	Functional earth (FE)

	Type	At terminals in cabinet	At connection point; base, axis 3, or axis 6	Cable/part area	Allowed capacity
A	<b>Customer Power (CP)</b>				
	Utility power	3	3	1.5 mm <sup>2</sup>	250 V AC, 5 A rms
	Protective earth	1	1	1.5 mm <sup>2</sup>	250 V AC
	Utility power	4	4	0.5 mm <sup>2</sup>	50 V DC, 1 A rms
B	<b>Customer Signal (CS)</b>				
	Signals shielded		8 (4x2)	0.24 mm <sup>2</sup>	30 V AC, 42 V DC, 1 A rms
D	<b>Customer bus (Ethernet)</b>				
	Bus signals	4	4	0.4 mm <sup>2</sup>	Ethernet CAT 5e, 100 Mbit <sup>i</sup>
E	<b>Media</b>				
	Air (PROC 1)		1	12.5 mm inner diameter	Max. air pressure 16 bar/230 PSI
F	<b>Functional Earth<sup>ii</sup></b>		1	10 mm <sup>2</sup>	600 V AC RMS

<sup>i</sup> Ethernet with wire colors according to PROFINET standard, M12-connectors.

<sup>ii</sup> When EtherNet is selected.

Continues on next page

### 3 Specification of variants and options

#### 3.4.4 Configuration result of DressPack options

*Continued*

#### DressPack options for spotwelding (SW)

The DressPack contents will differ depending on selected options. See table for signal content below.

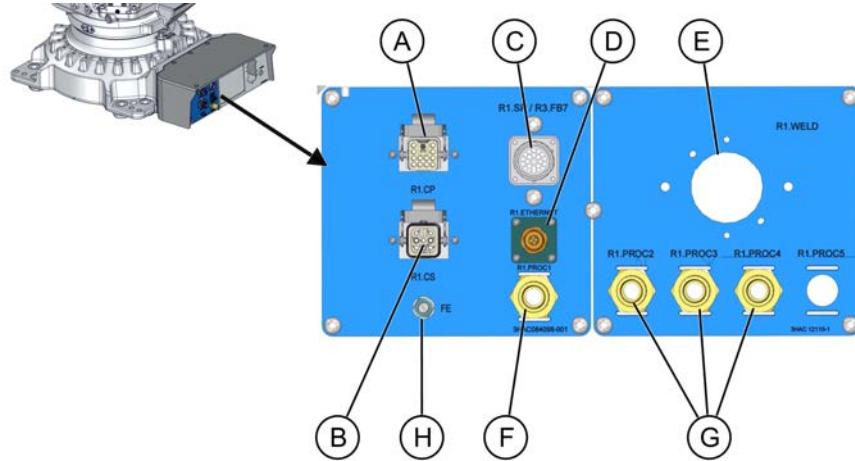

xx230000250

A	Customer power (CP)
B	Customer signal (CS)
C	Servo Power (SP)
D	ETHERNET
E	WELD3 x 35 mm <sup>2</sup> (spot welding)
F	PROC1 (1/2" hose, M22 x 1.5, 24 degree seal)
G	PROC2-4 (spot welding 1/2", M22 x 1.5, 24 degree seal)
H	Functional earth (FE)

	Type	At terminals in cabinet	At connection point; base, axis 3, or axis 6	Cable/part area	Allowed capacity
A	<b>Customer Power (CP)</b>				
	Utility power	3	3	1.5 mm <sup>2</sup>	250 V AC, 5 A rms
	Protective earth	1	1	1.5 mm <sup>2</sup>	250 V AC
	Utility power	4	4	0.5 mm <sup>2</sup>	50 V DC, 1 A rms
B	<b>Customer Signal (CS)</b>				
	Signals shielded		8 (4x2)	0.24 mm <sup>2</sup>	30 V AC, 42 V DC, 1 A rms
C	<b>Servo motor signals (SP)</b>				
	Servo motor power	At drive	3	1.5 mm <sup>2</sup>	600 VAC, 12 A rms
	Protective earth	At drive	1	1.5 mm <sup>2</sup>	600 VAC
	Signals twisted pair for resolver		6	0.23 mm <sup>2</sup>	50 V DC, 1 A rms
	Brake		2	0.5 mm <sup>2</sup>	50 V DC, 1 A rms
	Temperature control/PTC		2	0.5 mm <sup>2</sup>	50 V DC, 1 A rms

*Continues on next page*

### 3 Specification of variants and options

#### 3.4.4 Configuration result of DressPack options

Continued

	Type	At terminals in cabinet	At connection point; base, axis 3, or axis 6	Cable/part area	Allowed capacity
D	<b>Customer bus (Ethernet)</b>				
	Bus signals	4	4	0.4 mm <sup>2</sup>	Ethernet CAT 5e, 100 Mbit <sup>i</sup>
E	<b>Welding power (WELD3 x 35 mm<sup>2</sup>)</b>				
	Lower and upper arm		2	35 mm <sup>2</sup> ii	600 VAC, 150 A rms at 20°C (68°F)
	Protective earth (lower and upper arm)		1		
F	<b>Media</b>				
	Air (PROC 1)		1	12.5 mm inner diameter	Max. air pressure 16 bar/230 PSI
G	<b>Media</b>				
	(PROC2-4)		3	12.5 mm inner diameter M22 x 1.5, 24 degree seal	Max. air pressure 16 bar/230 PSI
H	<b>Functional Earth</b> iii		1	10 mm <sup>2</sup>	600 V AC RMS

i Ethernet with wire colors according to PROFINET standard, M12-connectors.

ii For LeanID upper arm 25 mm<sup>2</sup>, 135 A rms

iii When EtherNet is selected.

#### Empty conduit options

The dimension and requirements for empty cable conduit options are described in the product manual for the DressPack, see [References on page 7](#).

#### 3.4.5 Connector kits manipulator

##### General

Below is an example of a connector kit and its parts.



xx130000223

*Continues on next page*

### 3 Specification of variants and options

#### 3.4.5.1 Base - Connector kits

#### 3.4.5.1 Base - Connector kits

##### Available options

Option	Name	DressPack options	
		3325-11/13	3325-61/63
3330-2	CP/CS, Proc 1 base	X	X
3331-1	Weld Proc 2-4 base		X
3332-1	FB7 on base	X	



##### Note

Servo power connector kits are not available.

##### Option 3330-2, CP/CS, Proc 1 on base

This option offers a kit with connectors. This must be assembled by the customer. The kit contains the following components.

##### CP

Amount	Description	Size, material, etc.	Brand
1	Hood pegs, Han 3A		Harting
1	Insert, female, 12p		Harting
8	Crimp contact female	For 0.5 mm <sup>2</sup>	
8	Crimp contact female	For 1.0 mm <sup>2</sup>	
8	Crimp contact female	For 1.5 mm <sup>2</sup>	
8	Crimp contact female	For 2.5 mm <sup>2</sup>	
2	Coding pin, Han		Harting
1	Screw M3 with seal		Harting

##### CS

Amount	Description	Size, material, etc.	Brand
1	Hood pegs, Han 3A		Harting
1	Insert, female, 8p		Harting
8	Crimp contact female	For 0.14–0.37 mm <sup>2</sup>	
1	Screw M3 with seal		Harting

##### Media

Amount	Description	Size, material, etc.	Brand
1	Hose coupling	1/2", M22 x 1.5 Brass	

##### Ethernet

Amount	Description	Size, material, etc.	Brand
1	M12 Connector, Male, D-code	For 0.14–0.34 mm <sup>2</sup>	

Continues on next page



### 3 Specification of variants and options

#### 3.4.5.1 Base - Connector kits

*Continued*

#### Option 3331-1, Weld Proc 2-4 base

This option offers a kit with connectors. This must be assembled by the customer. The kit contains the following components.

#### WELD

Amount	Description	Size, material, etc.	Brand
1	Welding connector socket	TSB150/L-UR	Stäubli
3	Socket	For 35 mm <sup>2</sup>	
1	Form shroud welding conn.	202K174-3/42-0, for cable diameter 15.7-35 mm	Raychem

#### Media

Amount	Description	Size, material, etc.	Brand
4	Hose coupling	1/2", M22 x 1.5 Brass	

#### Option 3332-1, FB7 on base

This option offers a kit with connectors. This must be assembled by the customer. The kit contains the following components.

#### FB

Amount	Description	Size, material, etc.	Brand
1	Connector, 8p, Male	UTOW	
15	Pin	For 0.13–0.26 mm <sup>2</sup>	
1	Shrink boot adapter		
1	Bottle shaped shrink boot		

### 3 Specification of variants and options

#### 3.4.5.2 Axis 3 - Connector kits

#### 3.4.5.2 Axis 3 - Connector kits

##### Available options

Option	Name	DressPack options	
		3326-11/13	3326-61/63
3333-2	CP/CS bus, Proc 1 axis 3	X	X
3333-3	CP/CS Proc1, Servo & FB		X

##### Option 3333-2, CP/CS/CBus, Proc 1 axis 3

This option offers a kit with connectors. This must be assembled by the customer. The kit contains the following components.

##### CP

Amount	Description	Size, material, etc.	Brand
1	Hood pegs, Han 3A		Harting
1	Insert, male, 12p		Harting
8	Crimp contact male	For 0.5 mm <sup>2</sup>	
8	Crimp contact male	For 1.0 mm <sup>2</sup>	
8	Crimp contact male	For 1.5 mm <sup>2</sup>	
8	Crimp contact male	For 2.5 mm <sup>2</sup>	
2	Coding pin, Han		Harting
1	Screw M3 with seal		Harting

##### CS

Amount	Description	Size, material, etc.	Brand
1	Hood pegs, Han 3A		Harting
1	Insert, male, 8p		Harting
8	Crimp contact male	For 0.14–0.37 mm <sup>2</sup>	
1	Screw M3 with seal		Harting

##### Media

Amount	Description	Size, material, etc.	Brand
1	Hose coupling Parker Push lock	1/2", M22 x 1.5 Brass	

##### Ethernet

Amount	Description	Size, material, etc.	Brand
1	M12 Connector, Male, D-code	For 0.14–0.34 mm <sup>2</sup>	

Continues on next page

### 3 Specification of variants and options

#### 3.4.5.2 Axis 3 - Connector kits

*Continued*

#### Option 3333-3, CP/CS Proc1, Servo & FB

This option offers a kit with connectors. This must be assembled by the customer. The kit contains the following components.

#### CP

Amount	Description	Size, material, etc.	Brand
1	Hood pegs, Han 3A		Harting
1	Insert, male, 12p		Harting
8	Crimp contact male	For 0.5 mm <sup>2</sup>	
8	Crimp contact male	For 1.0 mm <sup>2</sup>	
8	Crimp contact male	For 1.5 mm <sup>2</sup>	
8	Crimp contact male	For 2.5 mm <sup>2</sup>	
2	Coding pin, Han		Harting
1	Screw M3 with seal		Harting

#### CS

Amount	Description	Size, material, etc.	Brand
1	Hood pegs, Han 3A		Harting
1	Insert, male, 8p		Harting
8	Crimp contact male	For 0.14–0.37 mm <sup>2</sup>	
1	Screw M3 with seal		Harting

#### Media

Amount	Description	Size, material, etc.	Brand
1	Hose coupling Parker Push lock	1/2", M22 x 1.5 Brass	

#### Ethernet

Amount	Description	Size, material, etc.	Brand
1	M12 Connector, Male, D-code	For 0.14–0.34 mm <sup>2</sup>	

#### SP

Amount	Description	Size, material, etc.	Brand
1	Hood pegs, Han 3A		Harting
1	Insert, male, 12p		Harting
8	Crimp contact male	For 0.5 mm <sup>2</sup>	
8	Crimp contact male	For 1.0 mm <sup>2</sup>	
8	Crimp contact male	For 1.5 mm <sup>2</sup>	
8	Crimp contact male	For 2.5 mm <sup>2</sup>	
2	Coding pin, Han		Harting
1	Screw M3 with seal		Harting

*Continues on next page*

### 3 Specification of variants and options

---

#### 3.4.5.2 Axis 3 - Connector kits

*Continued*

FB

<b>Amount</b>	<b>Description</b>	<b>Size, material, etc.</b>	<b>Brand</b>
1	Hood pegs, Han 3A		Harting
1	Insert, male, 8p		Harting
8	Crimp contact male	For 0.14–0.37 mm <sup>2</sup>	
1	Screw M3 with seal		Harting
1	Coding pin, Han D, female		Harting

#### 3.4.5.3 Axis 6 - Connector kits

##### Available options

Option	Name	DressPack options	
		3326-11/13	3326-61/63
3334-2	CP/CS bus axis 6	X	X
3334-3	CP/CS Proc1, Servo & FB		X
3335-1	Weld Proc 2-4 axis6		X

##### Option 3334-2, CP/CS/CBus, Proc 1 axis 6

This option offers a kit with connectors. This must be assembled by the customer. The kit contains the following components.

##### CP

Amount	Description	Size, material, etc.	Brand
1	Hood pegs, Han 3A		Harting
1	Insert, male, 12p		Harting
8	Crimp contact male	For 0.5 mm <sup>2</sup>	
8	Crimp contact male	For 1.0 mm <sup>2</sup>	
8	Crimp contact male	For 1.5 mm <sup>2</sup>	
8	Crimp contact male	For 2.5 mm <sup>2</sup>	
2	Coding pin, Han		Harting
1	Screw M3 with seal		Harting

##### CS

Amount	Description	Size, material, etc.	Brand
1	Hood pegs, Han 3A		Harting
1	Insert, male, 8p		Harting
8	Crimp contact male	For 0.14–0.37 mm <sup>2</sup>	
1	Screw M3 with seal		Harting

##### Media

Amount	Description	Size, material, etc.	Brand
1	Hose coupling Parker Push lock	1/2", M22 x 1.5 Brass	

##### Ethernet

Amount	Description	Size, material, etc.	Brand
1	M12 Connector, Female, D-code	For cable diameter 5.7–8.8 mm <sup>2</sup>	Harting
4	Socket		

*Continues on next page*

### 3 Specification of variants and options

#### 3.4.5.3 Axis 6 - Connector kits

Continued

##### Option 3334-3, CP/CS Proc 1, Servo & FB

This option offers a kit with connectors. This must be assembled by the customer. The kit contains the following components.

##### CP

Amount	Description	Size, material, etc.	Brand
1	Hood pegs, Han 3A		Harting
1	Insert, male, 12p		Harting
8	Crimp contact male	For 0.5 mm <sup>2</sup>	
8	Crimp contact male	For 1.0 mm <sup>2</sup>	
8	Crimp contact male	For 1.5 mm <sup>2</sup>	
8	Crimp contact male	For 2.5 mm <sup>2</sup>	
2	Coding pin, Han		Harting
1	Screw M3 with seal		Harting

##### CS

Amount	Description	Size, material, etc.	Brand
1	Hood pegs, Han 3A		Harting
1	Insert, male, 8p		Harting
8	Crimp contact male	For 0.14–0.37 mm <sup>2</sup>	
1	Screw M3 with seal		Harting

##### Media

Amount	Description	Size, material, etc.	Brand
1	Hose coupling Parker Push lock	1/2", M22 x 1.5 Brass	

##### Ethernet

Amount	Description	Size, material, etc.	Brand
1	M12 Connector, Female, D-code	For cable diameter 5.7–8.8 mm <sup>2</sup>	Harting
4	Socket	For 0.13–0.33 mm <sup>2</sup>	

##### SP

Amount	Description	Size, material, etc.	Brand
1	M23 Hybrid Panel Connector, 8p, Male	For cable diameter 7.0–12.0 mm <sup>2</sup>	Hummel
4	Crimp pin 1 mm, AWG 24-17	For 0.25–1.0 mm <sup>2</sup>	
4	Crimp pin 2 mm, AWG 18-24	For 0.75–2.5 mm <sup>2</sup>	
4	Crimp pin 2 mm, AWG 14-12	For 2.5–4.0 mm <sup>2</sup>	

Continues on next page

### 3 Specification of variants and options

#### 3.4.5.3 Axis 6 - Connector kits

*Continued*

FB

Amount	Description	Size, material, etc.	Brand
1	M23 Signal Panel Connector, 12p, Male	For cable diameter 7.0–12.0 mm <sup>2</sup>	Hummel
12	Pin AWG 28-20	For 0.08–0.56 mm <sup>2</sup>	
12	Pin AWG 26-17	For 0.14–1.0 mm <sup>2</sup>	
12	Pin AWG 18-16	For 0.75–1.5 mm <sup>2</sup>	

#### Option 3335-1, Weld Proc 2-4 axis6

This option offers a kit with connectors. This must be assembled by the customer. The kit contains the following components.

WELD

Amount	Description	Size, material, etc.	Brand
1	Welding connector	RobiFix-B-L	Stäubli
3	Socket	For 25 mm <sup>2</sup>	Stäubli

Media

Amount	Description	Size, material, etc.	Brand
4	Hose coupling Parker Push lock	1/2", M22 x 1.5 Brass	

### 3 Specification of variants and options

---

#### 3.4.6 Application floor cables

#### 3.4.6 Application floor cables

---

##### Parallel cable - Length

Option	Description	Note
3201-2	7 m	
3201-3	15 m	
3201-5	30 m	

---

##### Ethernet cable - Length



##### Note

Occupies 1 Ethernet port.

Option	Description	Note
3202-2	7 m	Includes Parallel cable
3202-3	15 m	Includes Parallel cable
3202-5	30 m	Includes Parallel cable

---

##### CC-Link cable - Length

Option	Description	Note
3205-2	7 m	Includes Parallel cable
3205-3	15 m	Includes Parallel cable
3205-5	30 m	Includes Parallel cable

---

##### Servo cable 1 axis - Length

Option	Description	Note
3206-2	7 m	
3206-3	15 m	
3206-5	30 m	



## 3.5 Warranty

### Warranty

For the selected period of time, ABB will provide spare parts and labor to repair or replace the non-conforming portion of the equipment without additional charges. During that period, it is required to have a yearly *Preventative Maintenance* according to ABB manuals to be performed by ABB. If due to customer restrains no data can be analyzed with ABB Connected Services for robots with OmniCore controllers, and ABB has to travel to site, travel expenses are not covered. The *Extended Warranty* period always starts on the day of warranty expiration. Warranty Conditions apply as defined in the *Terms & Conditions*.



#### Note

This description above is not applicable for option *Stock warranty* [438-8]

Option	Type	Description
438-1	Standard warranty	Standard warranty is 12 months from <i>Customer Delivery Date</i> or latest 18 months after <i>Factory Shipment Date</i> , whichever occurs first. Warranty terms and conditions apply.
438-2	Standard warranty + 12 months	Standard warranty extended with 12 months from end date of the standard warranty. Warranty terms and conditions apply. Contact Customer Service in case of other requirements.
438-4	Standard warranty + 18 months	Standard warranty extended with 18 months from end date of the standard warranty. Warranty terms and conditions apply. Contact Customer Service in case of other requirements.
438-5	Standard warranty + 24 months	Standard warranty extended with 24 months from end date of the standard warranty. Warranty terms and conditions apply. Contact Customer Service in case of other requirements.
438-6	Standard warranty + 6 months	Standard warranty extended with 6 months from end date of the standard warranty. Warranty terms and conditions apply.
438-7	Standard warranty + 30 months	Standard warranty extended with 30 months from end date of the standard warranty. Warranty terms and conditions apply.
438-8	Stock warranty	<p>Maximum 6 months postponed start of standard warranty, starting from factory shipment date. Note that no claims will be accepted for warranties that occurred before the end of stock warranty. Standard warranty commences automatically after 6 months from <i>Factory Shipment Date</i> or from activation date of standard warranty in WebConfig.</p> <div data-bbox="826 1800 890 1863" data-label="Image"> </div> <div data-bbox="909 1814 976 1845" data-label="Section-Header"> <h4>Note</h4> </div> <div data-bbox="820 1868 1453 1926" data-label="Text"> <p>Special conditions are applicable, see <i>Robotics Warranty Directives</i>.</p> </div>

*Continues on next page*

### 3 Specification of variants and options

---

#### 3.5 Warranty

*Continued*

---

#### Warranty for DressPack



##### Note

Option 3326-11/13 upper arm DressPack MH3 is not covered by the warranty.  
Option 3326-30/50 upper arm DressPack empty conduit is not covered by warranty.

# Index

## A

Absolute Accuracy, 65  
Absolute Accuracy, calibration, 57  
ambient humidity  
  operation, 20  
  storage, 20  
ambient temperature  
  operation, 20  
  storage, 20  
Axis Calibration  
  calibration tool  
    article number, 64

## B

base plate, 44

## C

calibration  
  Absolute Accuracy type, 56  
  standard type, 56  
calibration, Absolute Accuracy, 57  
calibration marks, 58  
calibration position  
  scales, 58  
calibration scales, 58  
CalibWare, 56  
compensation parameters, 65

## D

dimensions  
  robot, 31  
direction of axes, 60  
DressPack warranty, 186

## E

equipment, robot, 31  
extended working range, 160  
extension zone concept, 84  
extension zone limits, 84  
extra equipment, 31

## F

fitting, equipment, 31  
foundation  
  requirements, 19

## G

Gravity Beta, 51

## H

humidity  
  operation, 20  
  storage, 20

## I

installation  
  equipment, 31  
inverted mounting, 51

## L

limitations, 85  
load, 83  
loads on foundation, 18

## M

maintenance, 16  
mounting, equipment, 31  
movable mechanical stop, 54

## N

negative directions, axes, 60

## O

operating conditions, 20  
option  
  Extended working range, 160  
options, 153

## P

positive directions, axes, 60  
product standards, 15  
protection classes, 20  
protection type, 20

## R

requirements on foundation, 19  
robot  
  dimensions, 31  
  equipment, fitting, 31  
  protection class, 20  
  protection types, 20  
  technical data, 17  
  working range, 23

## S

safety standards, 15  
scales on robot, 58  
securing the robot to foundation, attachment screws, 42  
speed, 85  
standards, 15  
  ANSI, 15  
  CAN, 15  
standard warranty, 185  
stock warranty, 185  
stopping distance, 85  
stopping time, 85  
storage conditions, 20  
sync marks, 58  
system parameter  
  Gravity Beta, 51

## T

technical data  
  robot, 17  
temperatures  
  operation, 20  
  storage, 20  
tilted mounting, 51  
torques on foundation, 18  
troubleshooting, 16  
turning radius, 27

## V

variants, 153

## W

warranty, 185  
warranty for DressPack, 186  
wcp, 84  
weight, 17  
working range, 28  
  robot, 23







**ABB AB**

**Robotics & Discrete Automation**

S-721 68 VÄSTERÅS, Sweden

Telephone +46 10-732 50 00

**ABB AS**

**Robotics & Discrete Automation**

Nordlysvegen 7, N-4340 BRYNE, Norway

Box 265, N-4349 BRYNE, Norway

Telephone: +47 22 87 2000

**ABB Engineering (Shanghai) Ltd.**

Robotics & Discrete Automation

No. 4528 Kangxin Highway

PuDong New District

SHANGHAI 201319, China

Telephone: +86 21 6105 6666

**ABB Inc.**

**Robotics & Discrete Automation**

1250 Brown Road

Auburn Hills, MI 48326

USA

Telephone: +1 248 391 9000

**[abb.com/robotics](http://abb.com/robotics)**